

OpenBAS

BUILDING
AUTOMATION
SYSTEM

OpenBAS-HV-NX10 Series

Building Automation Controller and HVAC
Automation Solution

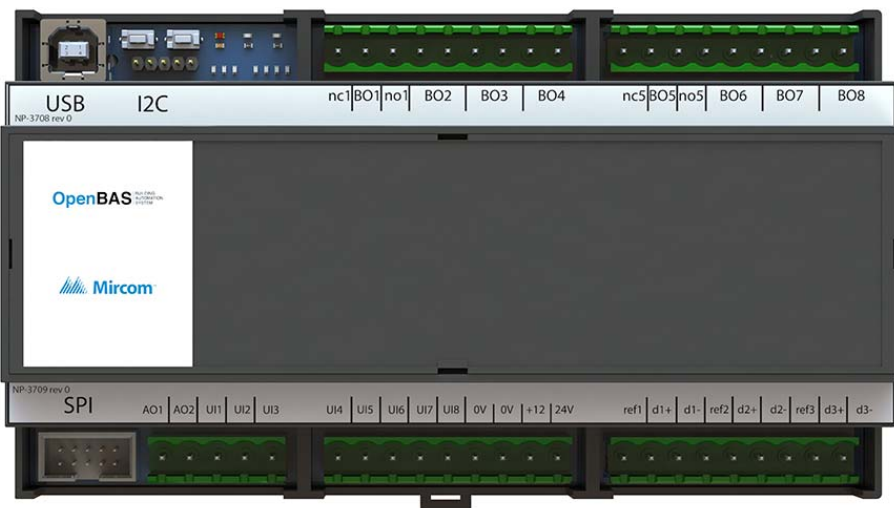

Table of Contents

1.0	Introduction	7
1.1	OpenBAS-HV-NX10 Series Building Automation Controller	7
1.2	Features	7
2.0	Overview	8
2.1	OpenBAS-HV-NX10 Series Components	8
3.0	Installation	10
3.1	Parts of the Enclosure	10
3.2	Controller Board Connections	13
3.3	Installing Accessories	13
3.4	Ethernet Controllers (OpenBAS-NWK-ETH3)	17
3.5	DIP Switches	17
3.6	USB	18
3.7	Reset and Download Buttons	18
3.8	Battery	18
3.9	Enclosure Dimensions	19
3.10	Assembly	20
3.11	Mounting the Enclosure	21
4.0	Field Wiring	22
4.1	Wiring the Terminals	22
4.2	Power Supply Connection	22
4.3	Universal Inputs	23
4.4	Analog Outputs	31
4.5	Digital Relay Outputs	33
4.6	Field Bus Connections and OpenBAS-ACC-DB9	36
4.7	Networking	37
4.8	Connections and LEDs on OpenBAS-HV-HX10D	38
4.9	Circuit Board LEDs	39
5.0	Specifications	40
6.0	Warranty and Warning Information	42

List of Figures

Figure 1	Parts of the enclosure	10
Figure 2	Tabs on enclosure	11
Figure 3	Lift tabs and remove circuit board	12
Figure 4	Board connections	13
Figure 5	COM ports	14
Figure 6	Location of factory-installed modules and jumpers	15
Figure 7	The jumper and RS-485 module are removed from P1	15
Figure 8	OpenBAS-ACC-RS232 is installed in P1	16
Figure 9	I2C, I2CB, N2, and SPI connections	17
Figure 10	DIP switches	18
Figure 11	Enclosure (back view)	19
Figure 12	Fit the circuit board in enclosure	20
Figure 13	Enclosure mounted on DIN rail (circuit board not shown)	21
Figure 14	Enclosure mounted on DIN rail (back view)	21
Figure 15	Power supply - 24 VAC or 24 VDC	23
Figure 16	Power supply - 12 VDC	23
Figure 17	Universal Inputs	23
Figure 18	Measuring VDC	29
Figure 19	Digital input voltage range	30
Figure 20	Analog outputs	32
Figure 21	Relay outputs	33
Figure 22	Field bus connections	36
Figure 23	Networking with OpenBAS-NWK-ETH3 with the included cable	37
Figure 24	Networking with OpenBAS-NWK-ETH3 over RS-458	37
Figure 25	Networking with RS-485	38
Figure 26	Connections and LEDs on the OpenBAS-HV-NX10D	38
Figure 27	LEDs	39

List of Tables

Table 1	OpenBAS-HV-NX10 Series Controllers	8
Table 2	OpenBAS-HV-NX10 Series Accessories	8
Table 3	OpenBAS-HV-NX10 Series Compatible Modules	9
Table 4	Analog Input Wiring	25
Table 5	Wiring a 1000 Ω temperature sensor	29
Table 6	Digital Input Wiring	31
Table 7	Analog Output Wiring	32
Table 8	Surge Protection on Relay Outputs	34
Table 9	Field Bus Ports	36

1.0 Introduction

This document provides information on installing the OpenBAS-HV-NX10 series Building Automation Controller.

1.1 OpenBAS-HV-NX10 Series Building Automation Controller

Mircom's OpenBAS-HV-NX10 Series building automation controller is an HVAC controller with an integrated PLC (programmable logic controller) and scheduler. It includes 18 hardware input/output points, 2 RS-485 field bus connections, USB, SPI, and I²C buses. The OpenBAS-HV-NX10L and OpenBAS-HV-NX10D models have an operator interface with LCD display and keyboard.

1.2 Features

Mircom's OpenBAS-HV-NX10 series Building Automation Controller integrates into Mircom's unified platform for automating HVAC and mechanical rooms as well as incorporating energy management features and lighting control to offer building owners and managers a seamless operation with the following features:

- Modular design to cover any small, medium or large project.
- Industry standard field bus protocols to integrate into any existing BAS system, such as BACnet, Modbus, Optomux, N2-Open, and ASCII.
- Advanced Networking to integrate into IP networks and use the most advanced features and protocols such as distributed computing, USB and Cloud storage, HTML5, JavaScript, XML, Ajax, SMS, and GSM.
- Universal inputs to connect any industry standard sensors.
- Modular add-ons for every Building Automation System solution.
- The OpenBAS software which provides owners and managers a single solution for managing all their building's automation needs.

2.0 Overview

2.1 OpenBAS-HV-NX10 Series Components

2.1.1 Controllers

Table 1 OpenBAS-HV-NX10 Series Controllers

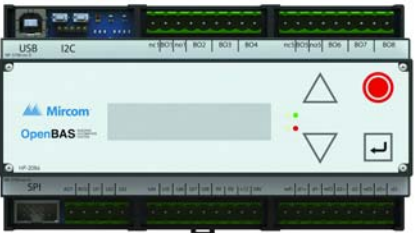
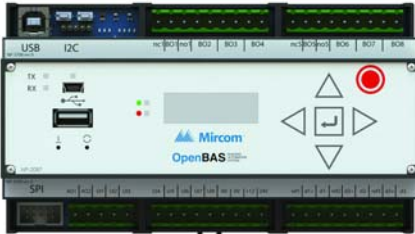
Picture	Model	Description
	OpenBAS-HV-NX10P	HVAC controller <ul style="list-style-type: none"> • Integrated programmable logic controller and scheduler • 18 hardware input/output points • 2 RS-485 field bus connections • USB, SPI and 1²C buses
	OpenBAS-HV-NX10L	HVAC controller plus the OpenBAS-HV-LCD display <ul style="list-style-type: none"> • Integrated programmable logic controller and scheduler • 18 hardware input/output points • 2 RS-485 field bus connections • USB, SPI and 1²C buses • Operator interface with LCD and keyboard
	OpenBAS-HV-NX10D	HVAC controller plus the OpenBAS-HV-CORE2 display <ul style="list-style-type: none"> • 32 bit dual core processor • Scheduler and 3 integrated programmable logic controllers • 18 hardware input/output points • 3 RS-485 field bus connections, • USB, SPI and 1²C buses • Operator interface with graphical LCD, keyboard, and secondary USB for data storage

2.1.2 Accessories

Accessories are powered from the controller.

Table 2 OpenBAS-HV-NX10 Series Accessories

Model	Description
OpenBAS-ACC-RS485	Optically isolated RS-485 converter
OpenBAS-ACC-RS232	RS-232 converter

Table 2 OpenBAS-HV-NX10 Series Accessories (Continued)

Model	Description
OpenBAS-ACC-DB9	DB9 adapter
OBS-ACC-32K128	128 KB plus 32 KB memory expansion
OpenBAS-ACC-TE1K	1000 Ω resistive silicon temperature sensor

2.1.3 Compatible Modules

Compatible modules are mounted separately from the controller.

Table 3 OpenBAS-HV-NX10 Series Compatible Modules

Model	Description
OpenBAS-HV-RF433R	Wireless 433 MHz RF receiver that integrates up to 10 wireless transmitters and thermostats into OpenBAS-HV-NX10 series controllers Mounts in a DIN rail-mounted box
OpenBAS-NWK-ETH3	Ethernet controller with support for multiple protocols <ul style="list-style-type: none"> • 2 field bus connections • 1 I²C connection • Mounts in a DIN rail-mounted box • Powered separately

3.0 Installation



Note: Installation of OpenBAS-HV-NX10 series automation controllers should be in accordance with the Canadian Electrical Code or the National Electrical Code, and comply with all local regulations. Final acceptance is subject to the Local Authority Having Jurisdiction (AHJ).

3.1 Parts of the Enclosure

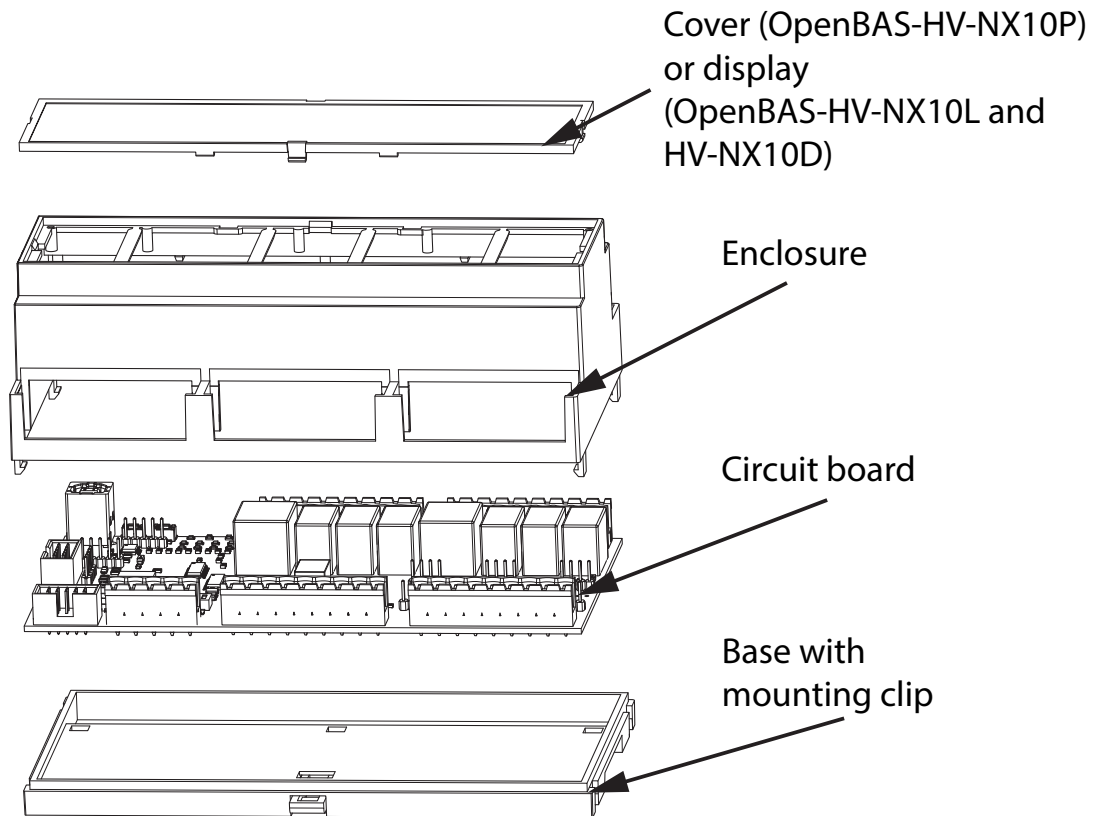

Figure 1 Parts of the enclosure

To remove the circuit board from the enclosure



Caution: **Risk of Electric Shock.** Disconnect the mains power and disconnect the controller from all wiring before opening the enclosure.



Attention: **Always hold circuit boards by the edges to prevent damage from static electricity. Always wear an anti-static bracelet when handling circuit boards.**

1. On OpenBAS-HV-NX10P, remove the cover. On OpenBAS-HV-NX10L and OpenBAS-HV-NX10D, remove the 4 screws and then remove the display.
2. Insert a flathead screwdriver under the tabs on the enclosure, shown in Figure 2, in order to lift the tabs and remove the base.

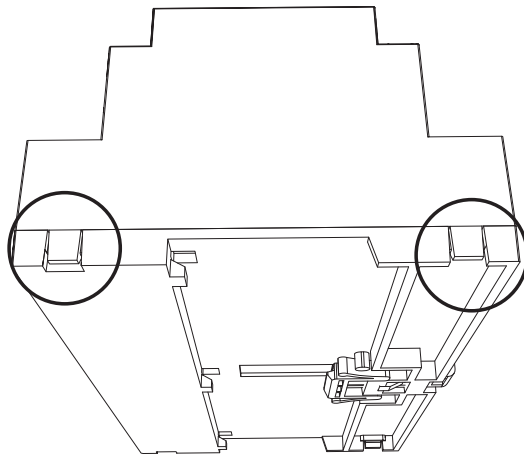

Figure 2 Tabs on enclosure

3. Hold the circuit board with one hand, and with the other hand lift the tabs so that you can remove the circuit board from the enclosure. See Figure 3.

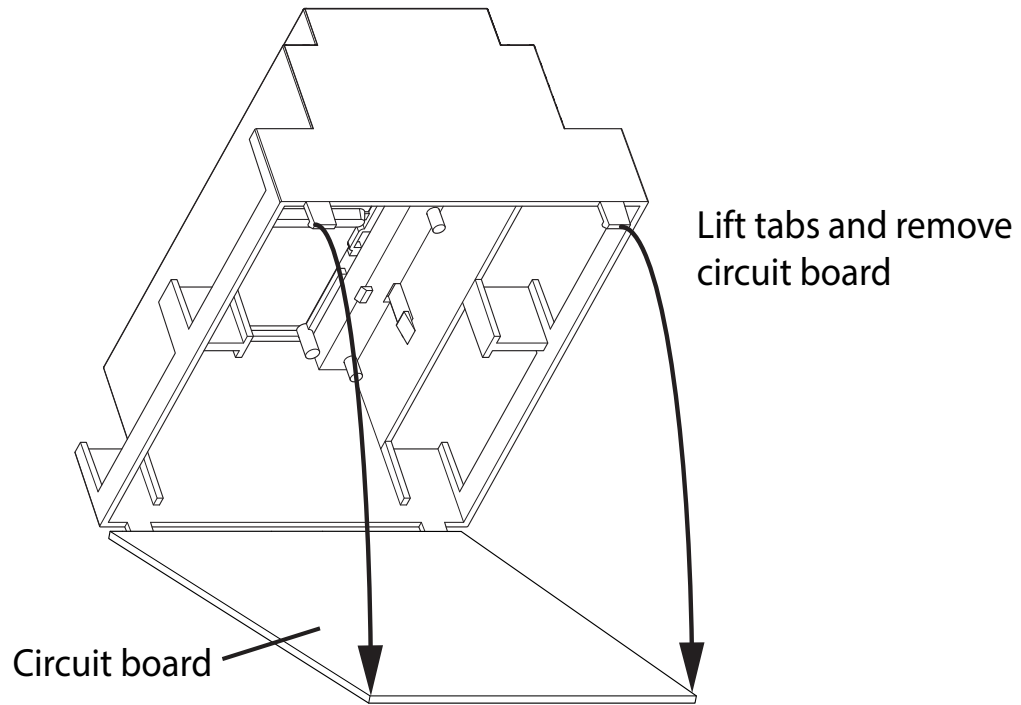

Figure 3 Lift tabs and remove circuit board



Attention: Be careful not to break the tabs. Do not apply excessive force.

3.2 Controller Board Connections

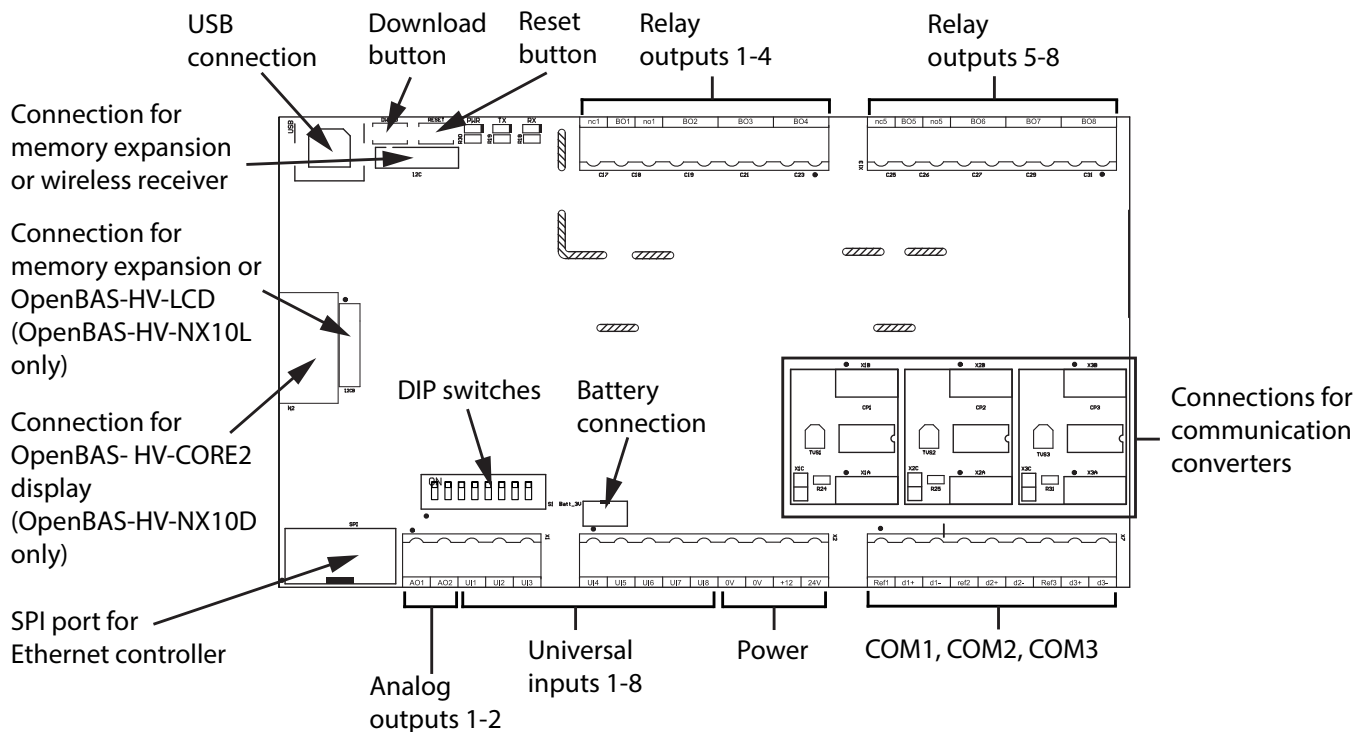

Figure 4 Board connections

3.3 Installing Accessories



Attention: This job must be performed only by a certified technician as dangerous voltages might be present inside of the enclosure. Always disconnect the power before installing accessories.

3.3.1 Communication Converters (OpenBAS-ACC-RS485, OpenBAS-ACC-RS232)

By default, the field bus ports (labeled COM1, COM2 and COM3) are configured as RS-485 through factory-installed modules. They can be changed to RS-232 or optically isolated RS-485 by installing the OpenBAS-ACC-RS232 or OpenBAS-ACC-RS485 converters.

The communication converters OpenBAS-ACC-RS485 and OpenBAS-ACC-RS232 attach to the connections labeled P1, P2, and P3 in Figure 5 below. Figure 5 also shows the relationship between the 3 converters and the field bus connections (labeled COM1, COM2, and COM3). P1 controls COM1, P2 controls COM2, and P3 controls COM3.

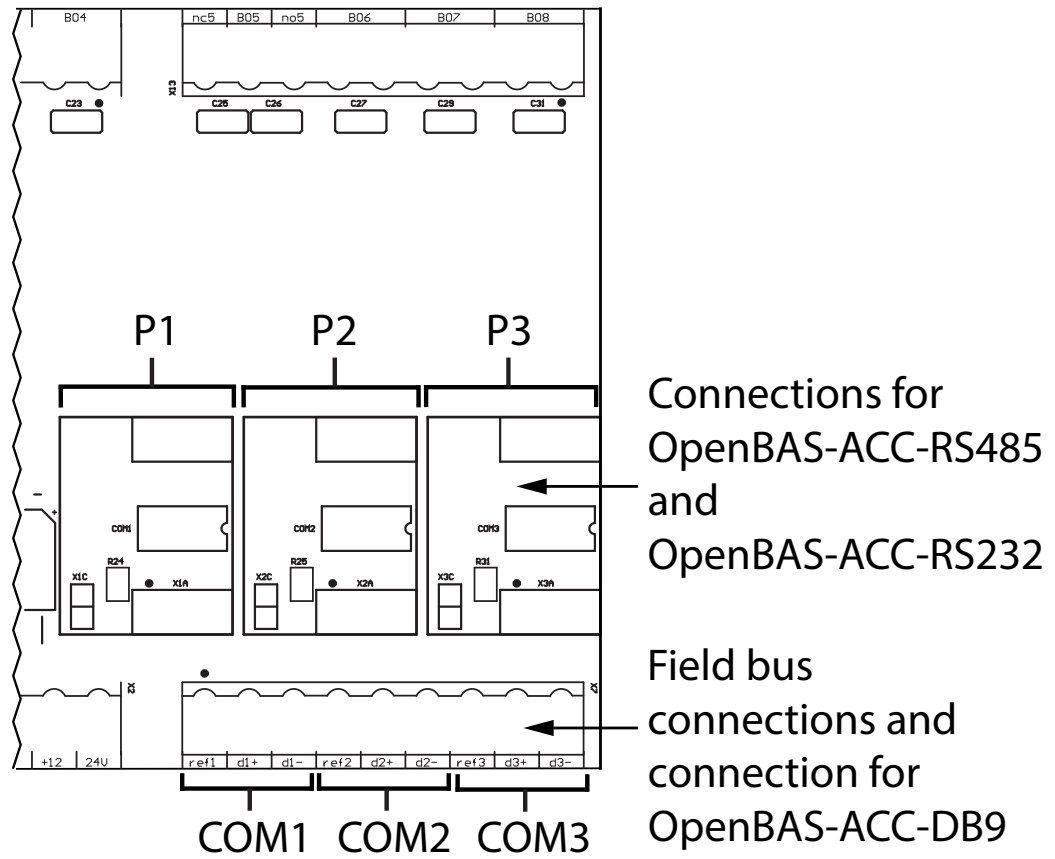

Figure 5 COM ports

For example, if OpenBAS-ACC-RS485 is installed in P1 and OpenBAS-ACC-RS232 is installed in P2, then COM1 functions as optically isolated RS-485, and COM2 functions as RS-232.



Note: P3 and COM3 are functional only on OpenBAS-HV-NX10D.

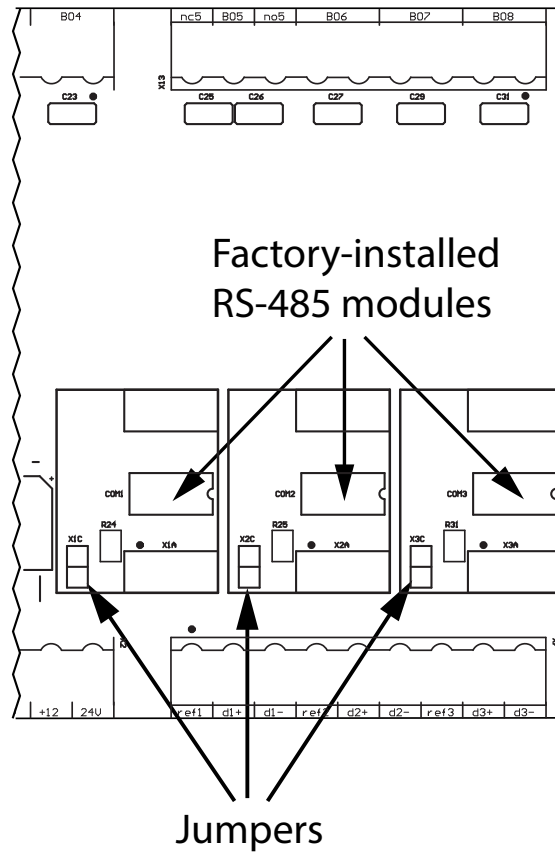
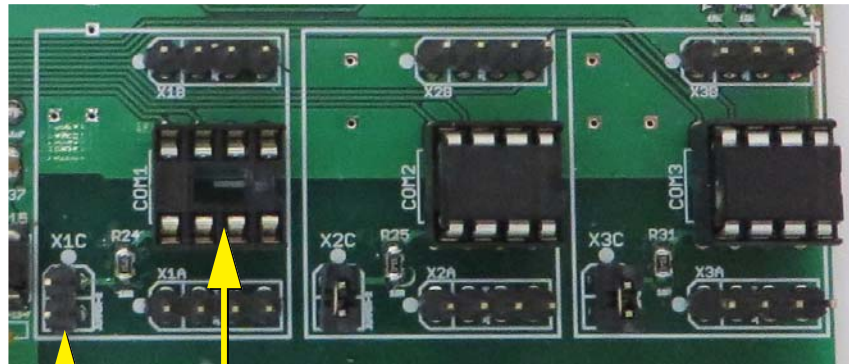

Figure 6 Location of factory-installed modules and jumpers

To install a communication converter

1. Open the jumper.
2. Remove the factory-installed RS-485 module.



Jumper open Factory-installed RS-485 module removed

Figure 7 The jumper and RS-485 module are removed from P1

3. Install the communication converter.

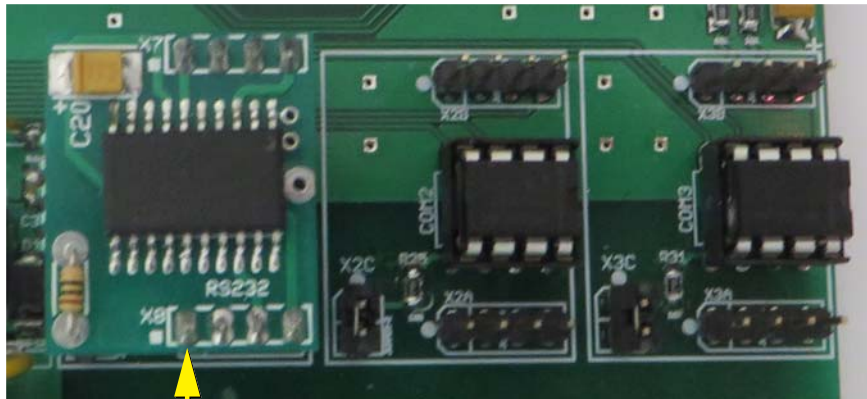

OpenBAS-ACC-RS232

Figure 8 OpenBAS-ACC-RS232 is installed in P1

3.3.2 Memory Expansion Card (OBS-ACC-32K128) and Wireless Receiver (OpenBAS-HV-RF433R)

Connect the memory expansion cards to either one of the two terminals shown in Figure 9. They are labeled I2C and I2CB.



Note: When connecting the I2C ports on 2 devices, make sure to connect pin 1 on the first device to pin 1 on the second device. Pin 1 is marked by a dot or a “1”.

Connect the OpenBAS-HV-RF433R wireless receiver to the port labeled I2C, so that it is accessible when the board is in the enclosure.

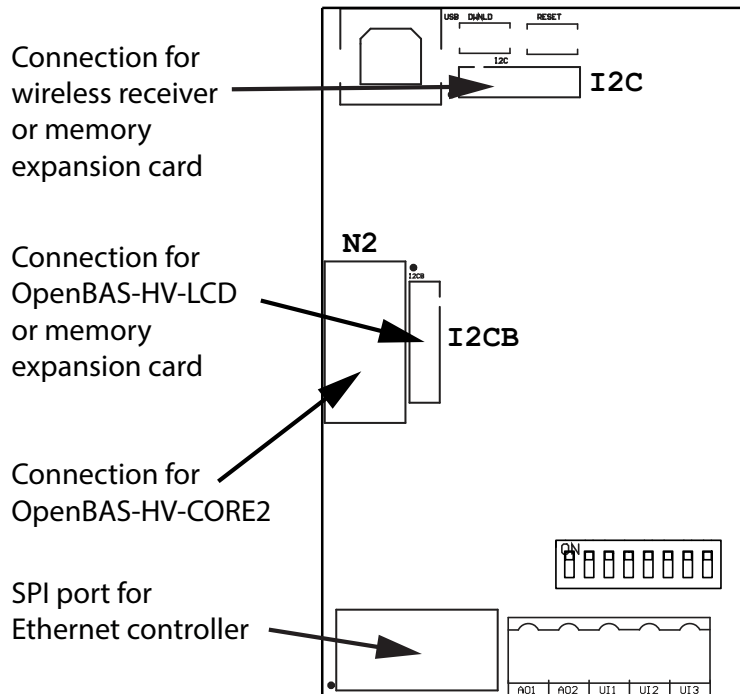

Figure 9 I2C, I2CB, N2, and SPI connections

3.3.3 Displays (OpenBAS-HV-LCD and OpenBAS-HV-CORE2)

The OpenBAS-HV-LCD display connects to I2CB, and the OpenBAS-HV-CORE2 display connects to N2 as shown in Figure 9.

3.4 Ethernet Controllers (OpenBAS-NWK-ETH3)

Connect an Ethernet controller to the terminal labeled SPI (shown in Figure 9) with the cable included with the Ethernet controller. See section 4.7 on page 37 for information on networking.

3.5 DIP Switches

The 8 DIP switches (shown in Figure 10) are used with the 8 universal inputs ONLY when the inputs are connected to resistive 1000 Ω temperature sensors.

In all other cases, make sure that the DIP switches are off.

For example, if you are going to connect universal input 1 to a resistive 1000 Ω temperature sensor, turn on DIP switch 1.

The DIP switches are set at the factory in the off position.

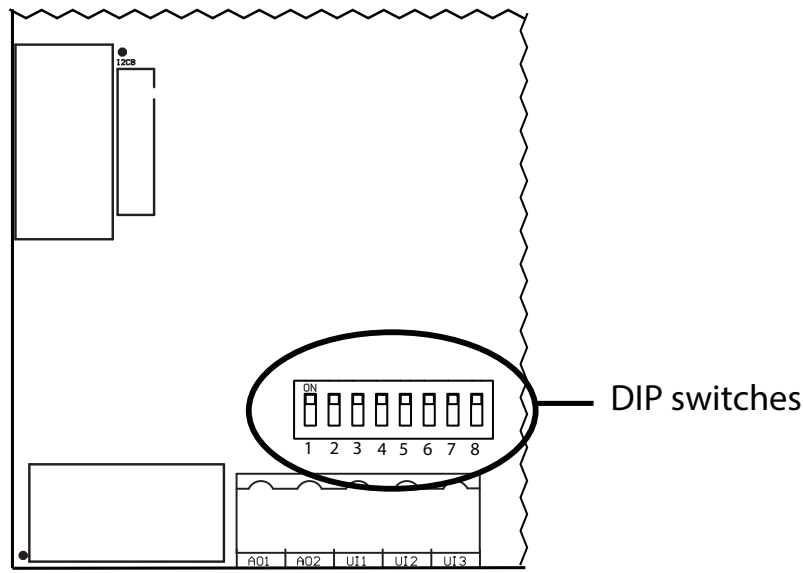

Figure 10 DIP switches

3.6 USB

The full speed USB 2.0 connection is shown in Figure 4. Connect a computer to this port in order to configure the controller.

3.7 Reset and Download Buttons

Press the **RESET** button to restart the controller.

The **DWNLD** button is used for loading firmware on to the controller.

Refer to the OpenBAS Programming Manual for information on upgrading controllers.

3.8 Battery



Attention: Caution – The battery used in this device may present a risk of fire or chemical burn if mistreated. Do not disassemble, heat above 60°C (140°F), or incinerate. Replace battery with FDK Corporation ML2430 batteries only. Use of another battery may present a risk of fire or explosion.

The battery is used only during power outages for real time clock and data retention. The Mircom part number for the battery is BT-025.

Install the battery before mounting the controller.

To install or replace the battery

1. Disconnect the mains power and open the mains breaker.
2. Disconnect all wiring from the unit.
3. Remove the top cover as described on page 21.
4. Disconnect the old battery.
5. Dispose of the used battery promptly. Keep away from children. Do not disassemble and do not dispose of in fire.
6. Connect the new battery to the connection shown in Figure 4. The battery wire can be connected only one way.

3.9 Enclosure Dimensions

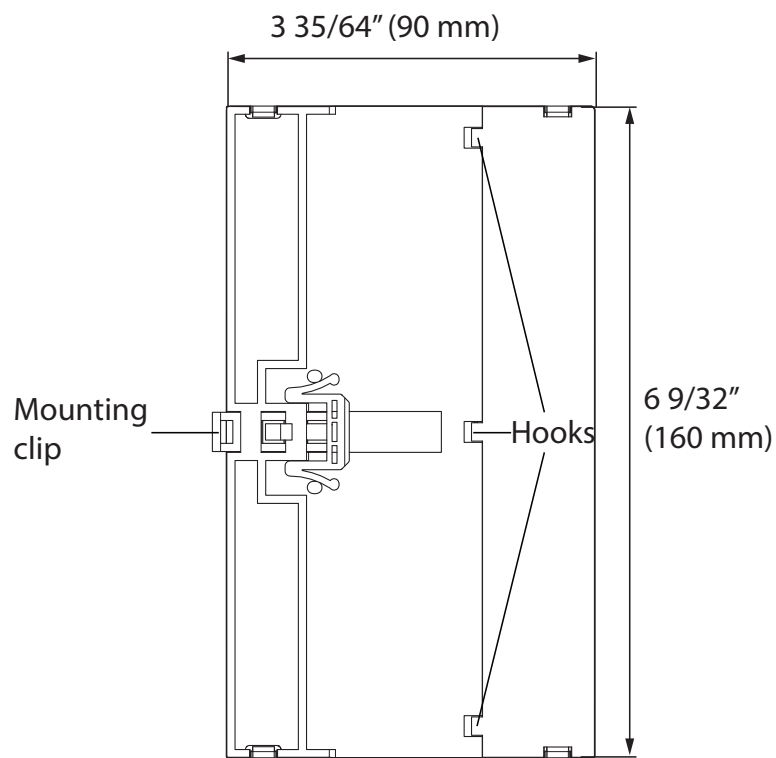

Figure 11 Enclosure (back view)

3.10 Assembly

To put the circuit board in the enclosure

1. Hold the circuit board with one hand, and with the other hand lift the tabs so that you can fit the circuit board into the enclosure as shown below.



Note: Make sure that the board is the right way up: the terminal labels on the enclosure must match the terminal labels on the circuit board.

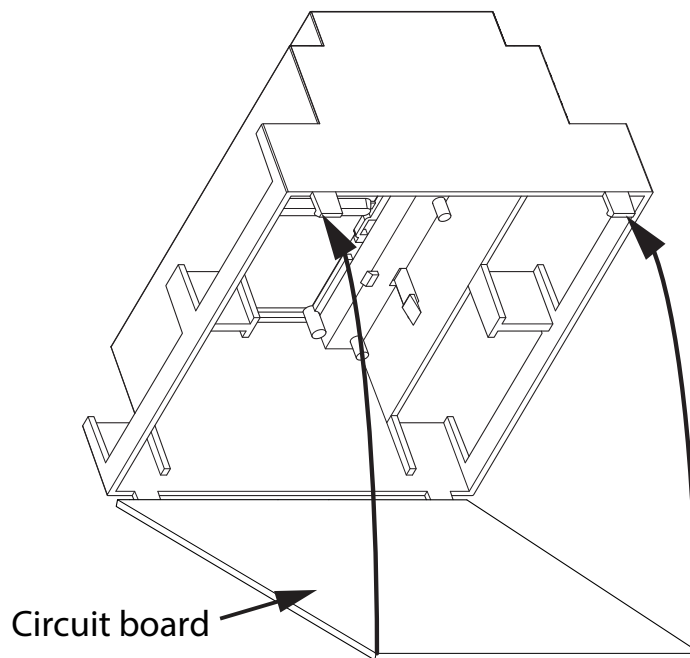

Figure 12 Fit the circuit board in enclosure

2. Snap the base onto the enclosure. Make sure that the mounting clip is on the bottom.
3. On OpenBAS-HV-NX10P, snap the cover in place.
On OpenBAS-HV-NX10L, connect the OpenBAS-HV-LCD display to the connection labeled I2CB.
On OpenBAS-HV-NX10D, connect the OpenBAS-HV-CORE2 display to the connection labeled N2.
Make sure that the Mircom logo is the right way up.
4. Secure the display with the 4 screws.



Attention: Always hold circuit boards by the edges to prevent damage from static electricity. Always wear an anti-static bracelet when handling circuit boards.

3.11 Mounting the Enclosure



Attention: Mount the enclosure on a DIN rail in a UL-compliant metal box. Do not drill holes in the enclosure or modify the enclosure in any way.

To mount the enclosure on a DIN rail

Mount the enclosure with terminal labels the right way up and the mounting clip on the bottom.

1. Mount a section of DIN rail so that there is enough space for the enclosure to be mounted.
2. Slide the hooks under the rail and push the enclosure to secure it on the DIN rail. The mounting clip locks it in place.

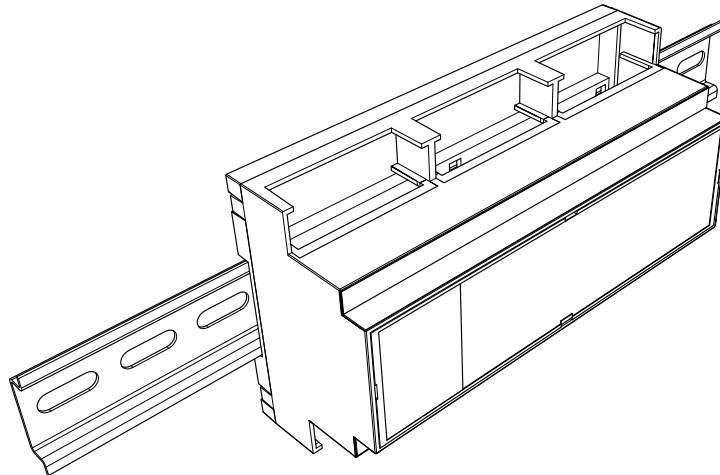

Figure 13 Enclosure mounted on DIN rail (circuit board not shown)

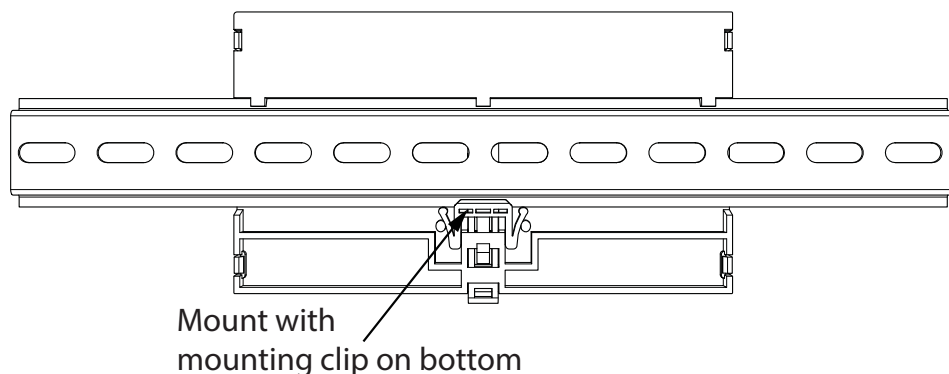

Figure 14 Enclosure mounted on DIN rail (back view)

To remove the enclosure from the DIN rail

- With your hands or with a small flathead screwdriver, pull the mounting clip to release the enclosure from the DIN rail, and carefully pull the enclosure off the DIN rail.

4.0 Field Wiring



Note: Installation of OpenBAS-HV-NX10 series automation controllers must be in accordance with the Canadian Electrical Code or the National Electrical Code, and comply with all local regulations. Final acceptance is subject to the Local Authority Having Jurisdiction (AHJ).

4.1 Wiring the Terminals

Figure 4 on page 13 shows the location of the terminals. The terminals are depluggable for ease of wiring.

4.1.1 Required Tools

Tools needed:

- Precision or jeweler's screwdriver set
- Wire cutter
- Wire stripper

4.1.2 Installation Tips

- Perform visual inspection of circuit board and parts for obvious issues.
- Use a wire tie to group wires for easy identification and neatness.

4.2 Power Supply Connection

The OpenBAS-HV-NX10 series controller can be powered 3 ways.

- 12 Vdc, 360 mA max.
- 24 Vdc, 450 mA max.
- 24 Vac 50/60 Hz, 500 mA max.

Notes:

- Use either of the terminals labeled **0V** to connect the negative side of the power supply.
- Use the **+12** or **24V** terminals to daisy chain a shared supply between more than one controller.

4.2.1 24 VDC or 24 VAC

When the controller is powered from the **24V** terminal, it can provide 12 VDC power to field devices through the **+12** terminal. In this case, the **+12** terminal can provide up to 250 mA.

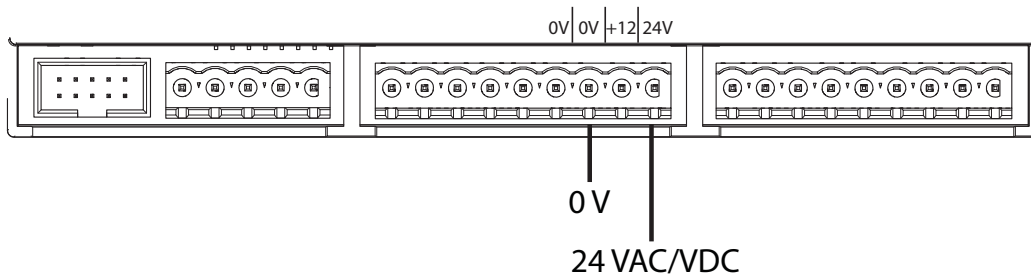

Figure 15 Power supply - 24 VAC or 24 VDC

4.2.2 12 VDC

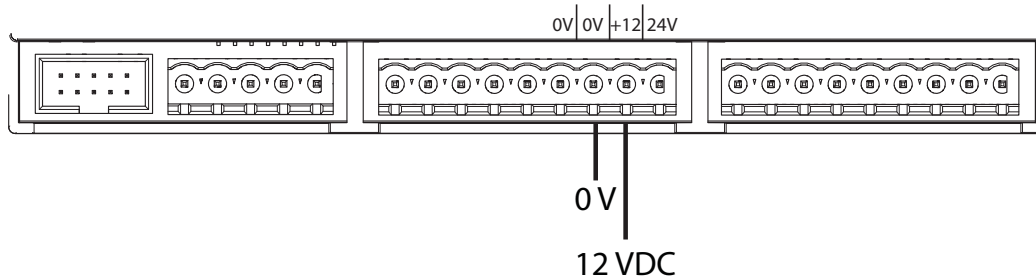

Figure 16 Power supply - 12 VDC



Caution: An appropriate UL listed class 2 power supply or transformer with necessary protection devices such as fuses or breakers should be used to limit the risk of fire. All local codes and regulations for installation must be observed.

4.3 Universal Inputs

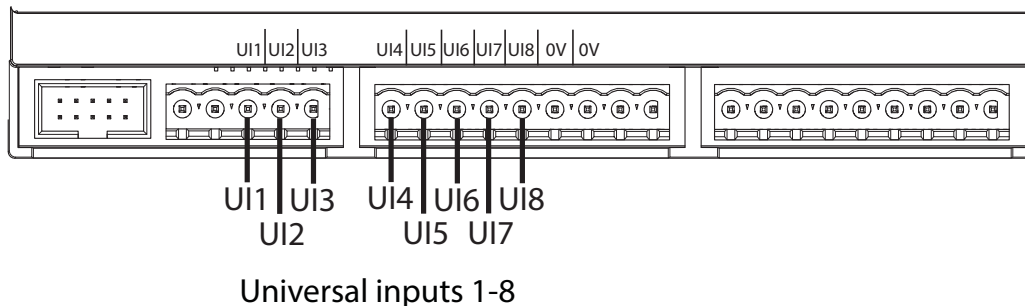

Figure 17 Universal Inputs

The controller has 8 universal inputs. Depending on the application, the universal inputs can be used the following ways:

- Analog Inputs (section 4.3.2 on page 24)
 - 0-10 VDC
 - 0-5 VDC

- Input for a resistive 1000 Ω temperature sensor (section 4.3.3 on page 29)
 - Measuring 24 VDC (section 4.3.4 on page 29)
 - Digital (binary) inputs (section 4.3.5 on page 29)
 - Pulse counters (section 4.3.5 on page 29)
- 0.5-4.5 VDC ratiometric
0-20 mA
4-20 mA
Thermocouple input with
x200 amplifiers
- for dry contacts being fed by
12 VDC
- active PNP 12 VDC
for dry contacts being fed by
12 VDC

4.3.1 Tips for Universal Inputs

- Use 18 AWG stranded wire.
- The absolute maximum voltage is 15 VDC.
- Fit the end of the wire with terminal connectors to provide a solid connection that can withstand temperature changes and vibration without becoming loose.
- Connect the common wires of sensors to either of the **0V** terminals.
- Turn the corresponding DIP switch on **ONLY** when using resistive 1000 Ω temperature sensors. See section 3.5 on page 17.
- When using 2 or more external power supplies, connect the negatives or commons of both power supplies to the 0V terminal of the controller.

To ensure that the universal inputs operate correctly, follow these guidelines:

- Limit the distance between the analog sensor and the controller to 10 m (30 ft). Mircom recommends shielded wire for noisy environments.
- If this distance is not possible, longer wire runs with shielded wire are allowed up to 30 m (100 ft). Connect the shield to any **0V** terminal on the controller, making sure to isolate the shield on the other end. Failing to do so creates ground loops.
- When possible, route the wiring inside metal piping and ground the piping for better results.
- Avoid running any analog signals near sources of electric noise such as: motors, ballasts, fluorescent lamps, variable frequency drives, high energy contacts, RF (radio frequency) transmitters, microwave ovens, and any other equipment that generates electromagnetic interference.
- Keep a minimum distance of 30 cm (1 ft) between analog input wiring and any conductor carrying more than 24 VAC.
- Follow good wiring and installation practices, and follow all local regulations and electrical codes.

4.3.2 Analog Inputs

Connect any sensor or transducer that outputs 0-5 V, 0.5-4.5 V ratiometric, or 0-10 V directly to the universal inputs when they are configured as analog inputs.

To use the universal inputs as analog inputs

1. Connect the appropriate analog signal to the universal input according to the diagrams below.
2. Configure the analog input type and then calibrate using the OpenBAS software.

Terminal Labeling on Field Devices

The positive terminal on field devices might be labeled one of the following:

+ +24 +PWR 24 +DC AC PWR

The negative terminal on field devices might be labeled one of the following:

- 0V GND Neg COM

Table 4 shows how to connect different devices to the analog inputs.



Attention: When using 2 or more external power supplies, connect the negatives or commons of both power supplies to the 0V terminal of the controller.

Table 4 Analog Input Wiring

Type of field device	Power source	Wiring diagram
12 VDC powered transducer with 1-10 VDC output	12 VDC power supply common to field device and controller.	
12 VDC powered transducer with 1-10 VDC output	24 VAC or VDC power supply common to field device and controller. The controller provides the 12 VDC to the field device.	

Table 4 Analog Input Wiring (Continued)

Type of field device	Power source	Wiring diagram
<p>24 V powered transducer with 1-10 VDC output</p>	<p>24 V external power supply common to field device and controller. Power can be 24 VDC or VAC as required by the field device.</p>	
<p>Transducer with 1-10 VDC output</p>	<p>External power supply for field device (depends on field device requirements) and 12 VDC external power supply for controller. Connect the negative or common of both power supplies to the 0V terminal of the controller.</p>	
<p>Transducer with 1-10 VDC output</p>	<p>External power supply for field device (depends on field device requirements) and 24 V external power supply for controller. Connect the negative or common of both power supplies to the 0V terminal of the controller.</p>	
<p>2-wire transducer with 4-20 mA or 0-20 mA output</p> <p>Connect an external 250 Ω ½ Watt 1% load resistor in parallel between the universal input terminal and 0V to provide a return path for the transducer signal current.</p>	<p>12 VDC power supply common to field device and controller.</p>	

Table 4 Analog Input Wiring (Continued)

Type of field device	Power source	Wiring diagram
<p>2-wire transducer with 4-20 mA or 0-20 mA output</p> <p>Connect an external 250 Ω ½ Watt 1% load resistor in parallel between the universal input terminal and 0V to provide a return path for the transducer signal current.</p>	<p>24 VDC power supply common to field device and controller.</p>	
<p>2-wire transducer with 4-20 mA or 0-20 mA output</p> <p>Connect an external 250 Ω ½ Watt 1% load resistor in parallel between the universal input terminal and 0V to provide a return path for the transducer signal current.</p>	<p>External power supply for field device (depends on field device requirements) and 24 V external power supply for controller.</p> <p>Connect the negative or common of both power supplies to the 0V terminal of the controller.</p>	
<p>2-wire transducer with 4-20 mA or 0-20 mA output</p> <p>Connect an external 250 Ω ½ Watt 1% load resistor in parallel between the universal input terminal and 0V to provide a return path for the transducer signal current.</p>	<p>External power supply for field device (depends on field device requirements) and 12 VDC external power supply for controller.</p> <p>Connect the negative or common of both power supplies to the 0V terminal of the controller.</p>	
<p>3-wire transducer with 4-20 mA or 0-20 mA output</p> <p>Connect an external 250 Ω ½ Watt 1% load resistor in parallel between the universal input terminal and 0V to provide a return path for the transducer signal current.</p>	<p>24 VAC power supply common to field device and controller.</p>	

Table 4 Analog Input Wiring (Continued)

Type of field device	Power source	Wiring diagram
<p>3 wire transducer with 4-20 mA or 0-20 mA output</p> <p>Connect an external 250 Ω ½ Watt 1% load resistor in parallel between the universal input terminal and 0V to provide a return path for the transducer signal current.</p>	<p>External power supply for field device (depends on field device requirements) and 24 V external power supply for controller.</p> <p>Connect the negatives or commons of both power supplies to the 0V terminal of the controller.</p>	
<p>3 wire transducer with 4-20 mA or 0-20 mA output</p> <p>Connect an external 250 Ω ½ Watt 1% load resistor in parallel between the universal input terminal and 0V to provide a return path for the transducer signal current.</p>	<p>External power supply for field device (depends on field device requirements) and 12 VDC external power supply for controller.</p> <p>Connect the negatives or commons of both power supplies to the 0V terminal of the controller.</p>	
<p>J or K Thermocouples</p> <p>When using J or K thermocouples, install a x200 low offset amplifier.</p>	<p>24 VAC or VDC power supply to controller.</p> <p>The controller provides the 12 VDC and a maximum current of 250 mA to the field device.</p>	
<p>J or K Thermocouples</p> <p>When using J or K thermocouples, install a x200 low offset amplifier.</p>	<p>12 VDC power supply common to field device and controller.</p>	

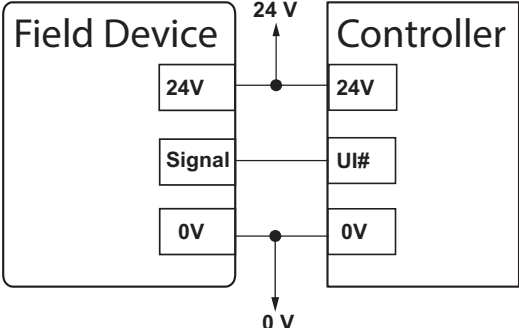
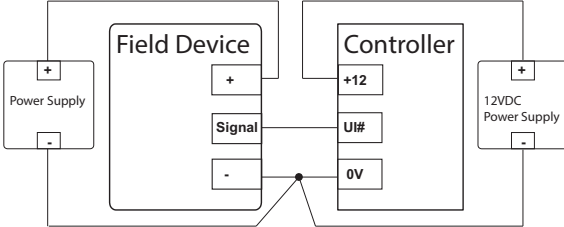
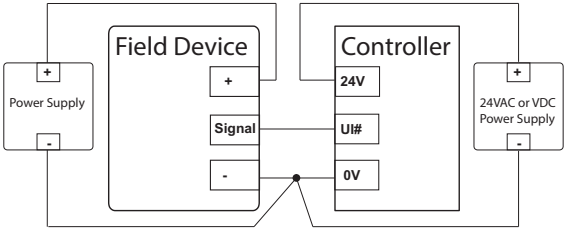
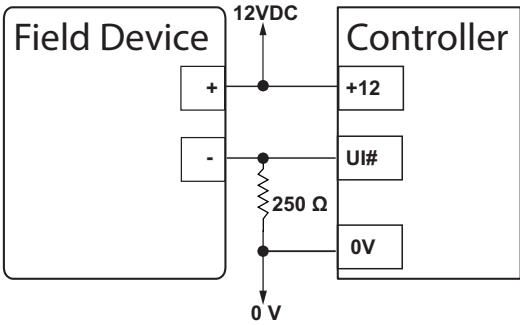
4.3.3 Resistive 1000 Ω Temperature Sensor

For resistive temperature sensors, the corresponding DIP switch must be ON. See section 3.5 on page 17. For all other devices, the DIP switch must be OFF.

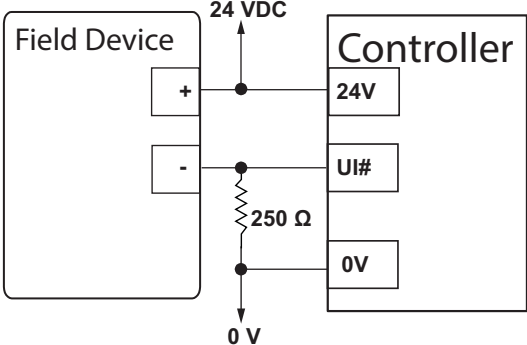
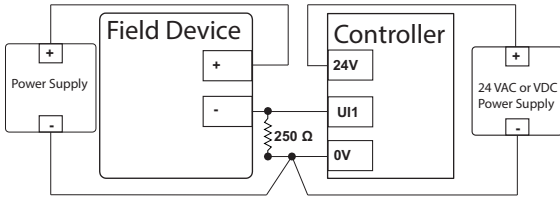
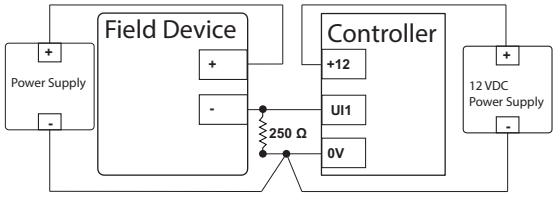
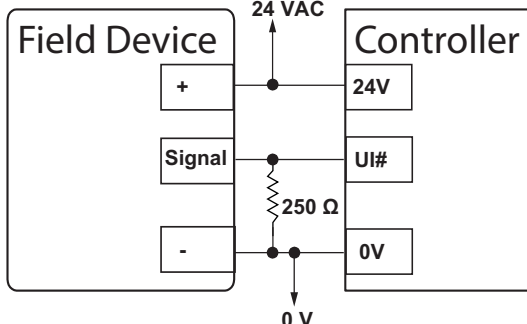
Table 5 Wiring a 1000 Ω temperature sensor

Type of field device	Power source	Wiring diagram
1000 Ω nickel or silicon resistive temperature sensor, for instance OpenBAS-ACC-TE1K or any PTC (positive temperature coefficient) thermistors	N/A	

4.3.4 Measuring 24 VDC with Analog Inputs

If you want to measure 24 VDC voltages, add a 15 kΩ ½ Watt 1% resistor in series with the higher voltage to be measured. See Figure 18.

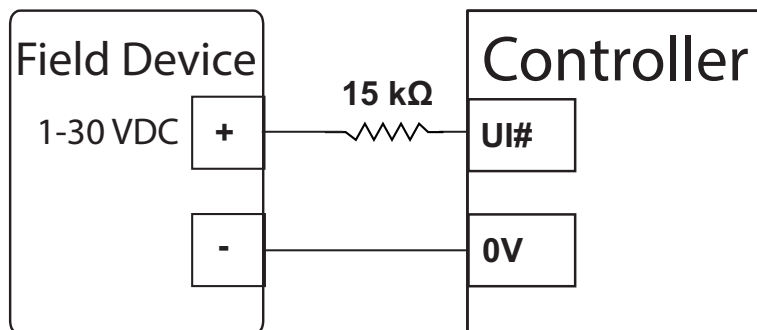

Figure 18 Measuring VDC



Caution: You can measure up to 30 VDC. A higher voltage will damage the controller.

Only DC voltages can be input to the universal inputs. Applying AC voltages or inverting the polarity will provide incorrect readings, and can eventually damage the inputs.

4.3.5 Digital Inputs

The 8 universal inputs can receive digital signals. These are signals that represent only two states.

The digital inputs have the following ranges:

- **ZERO (0)** is valid for an input voltage between 0 to 4 VDC
- **ONE (1)** is valid for an input voltage between 8 to 12 VDC

Any voltage that lies between 4.1 to 7.9 V can give ambiguous results and must be avoided. See Figure 19.

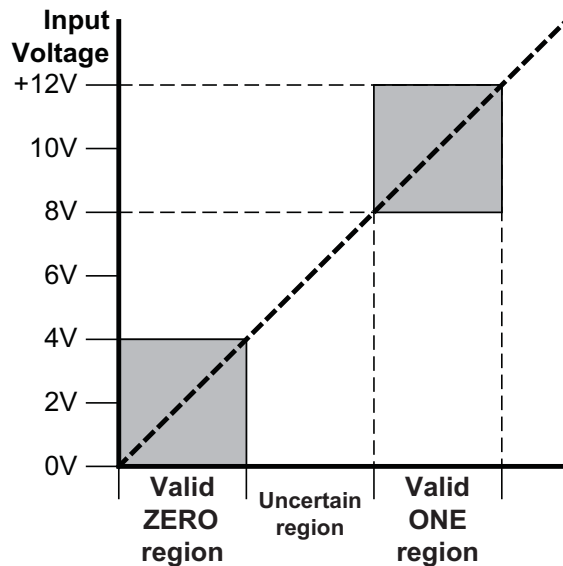

Figure 19 Digital input voltage range

The digital inputs can be used as frequency or pulse counters with these specifications:

- Digital inputs 1-2 can measure square wave or pulsed signals. The maximum measurable frequency is 250 Hz (15,000 pulses per minute). The minimum pulse width detectable is 2 milliseconds.
- Digital inputs 3-8 can measure frequencies up to 10 Hz (600 pulses per minute). The minimum pulse width detectable is 50 milliseconds.

Dry contact, push buttons, magnetic reed switches or PNP transistors must supply voltage to the digital input for correct operation.

To use the universal inputs as digital inputs

1. Connect the appropriate digital signal to the universal input according to the diagrams in Table 6.
2. Configure the digital input type using the OpenBAS software.

Table 6 shows how to connect different devices to the digital inputs.

Table 6 Digital Input Wiring

Type of field device	Power source	Wiring diagram
Dry contact switch or high switched PNP transistor Note: If you use a PNP transistor, the voltage must be DC.	External 12 VDC power supply to feed the dry contact switches	
Dry contact switch or high switched PNP transistor Note: If you use a PNP transistor, the voltage must be DC.	12 VDC generated by the controller	
Dry contact switch or high switched PNP transistor	24 VDC power supply to feed the dry contact switches	

4.4 Analog Outputs

The two analog outputs have short-circuit and thermal protection. They provide 10 mA with a maximum voltage of 10 VDC to control the speed of a motor, the position of a valve or damper, or light intensity using electronic ballasts with 0-10 V inputs.



Caution: Applying any external voltage less than 0 V or greater than 10 V will damage the analog outputs.

To ensure that analog outputs operate correctly, follow these guidelines:

- Use 18 AWG stranded wire.
- Limit the distance between the field device and the controller to 10 m (30 ft). Mircom recommends shielded wire for noisy environments.

- If this distance is not possible, longer wire runs with shielded wire are allowed up to 30 m (100 ft). Connect the shield to any **0V** terminal on the controller, making sure to isolate the shield on the other end. Failing to do so creates ground loops.
- When possible, route the wiring inside metal piping and ground the piping for better results.
- Avoid running any analog signals near sources of electric noise such as: motors, ballasts, fluorescent lamps, variable frequency drives, high energy contacts, RF (radio frequency) transmitters, microwave ovens, and any other equipment that generates electromagnetic interference.
- Keep a minimum distance of 30 cm (1 ft) between analog output wiring and any conductor carrying more than 24 VAC.
- Follow good wiring and installation practices, and follow all local regulations and electrical codes.
- Use either of the terminals labeled **0V** to connect the return signal or common.

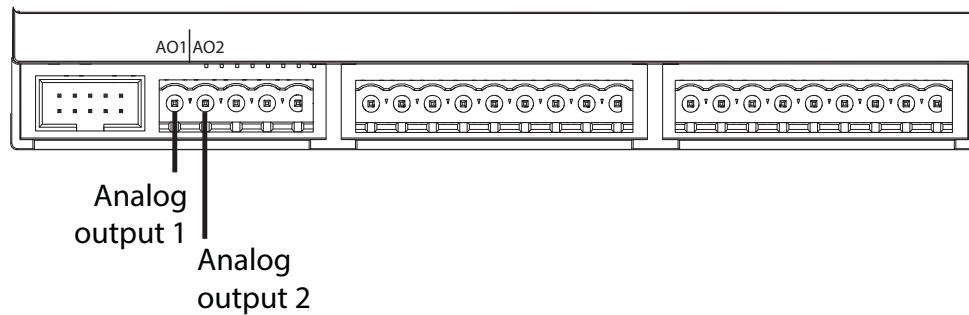

Figure 20 Analog outputs

Table 7 shows how to connect devices to the analog outputs.

Table 7 Analog Output Wiring

Type of field device	Wiring diagram
Variable-frequency drive with 1-10 VDC input for speed control Or Dimmable ballast with 0-10 VDC control input	<p>The diagram shows a box labeled 'Field Device' with two terminals: '+' and '-'. To its right is a box labeled 'Controller' with two terminals: 'AO#' and '0V'. A wire connects the '+' terminal of the Field Device to the 'AO#' terminal of the Controller. Another wire connects the '-' terminal of the Field Device to the '0V' terminal of the Controller.</p>

Table 7 Analog Output Wiring (Continued)

Type of field device	Wiring diagram
24 VAC or VDC valve or damper with 1-10 VDC control input	

4.5 Digital Relay Outputs

Outputs 1 and 5 have common (labeled **BO**), normally open (labeled **no**), and normally closed (labeled **nc**) contacts.

Outputs 2-4 and 6-8 have 2 contacts and can be configured in the software as normally open or normally closed. By default they are normally open.



Attention: If DC voltage with anything other than purely resistive load is used on the digital outputs, then the appropriate protective devices must be installed.

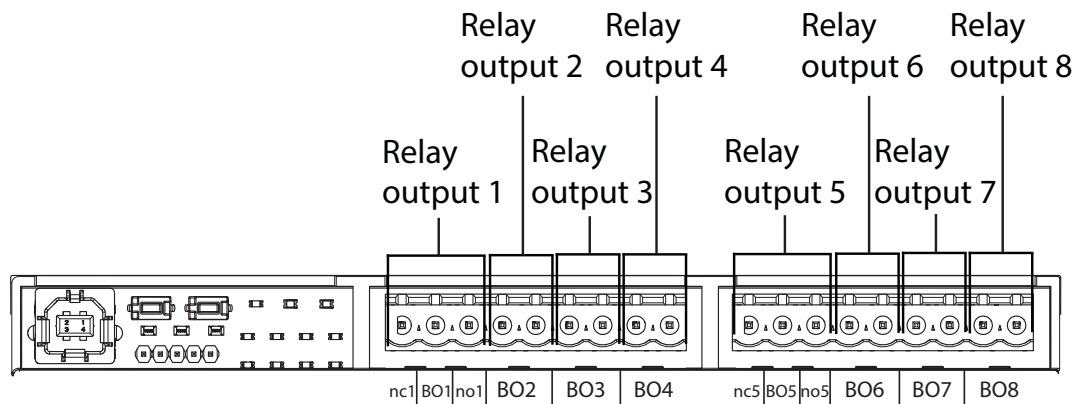

Figure 21 Relay outputs



Note: Installation of OpenBAS-HV-NX10 series automation controllers must be in accordance with the Canadian Electrical Code or the National Electrical Code, and comply with all local regulations. Final acceptance is subject to the Local Authority Having Jurisdiction (AHJ).

Relay output connections can contain hazardous voltages that present the risk of electric shock. Caution must be exercised when handling these terminals. Only certified technicians should handle these terminals.

4.5.1 Surge Protection

The provisions shown in Table 8 should help to reduce electrical noise that could affect nearby equipment.



Attention: Always install safety breakers and fuses according to the load and voltage, and in accordance with Canadian Electrical Code or National Electric Code. Follow all local regulations.

Table 8 Surge Protection on Relay Outputs

Type of field device	Notes	Wiring diagram
Single phase motor	Install a 120 V MOV surge protector in parallel with motor to suppress noise.	
120 V lamp with ballast	Install a 120 V MOV surge protector in parallel with solenoid coil to suppress noise. Note: Only lamps with ballast require surge protection. Incandescent, LED, and halogen lamps do not require surge protection.	

Table 8 Surge Protection on Relay Outputs (Continued)

Type of field device	Notes	Wiring diagram
120 VAC LED lamp	High impedance lamps such as LED lamps require a 15 kΩ 1W 5% resistor in parallel to the lamp to prevent current leakage.	
120 VAC coil	Install a 120 V MOV surge protector in parallel with solenoid coil to suppress noise.	
24 VDC coil	Install a 1N4007 reverse polarizing diode in parallel with DC solenoid coil to suppress flyback voltage.	
24 VDC lamp	N/A	

Table 8 Surge Protection on Relay Outputs (Continued)

Type of field device	Notes	Wiring diagram
24 VAC coil	Install a 36 V MOV surge protector in parallel with coil of solenoid to suppress noise.	

4.6 Field Bus Connections and OpenBAS-ACC-DB9

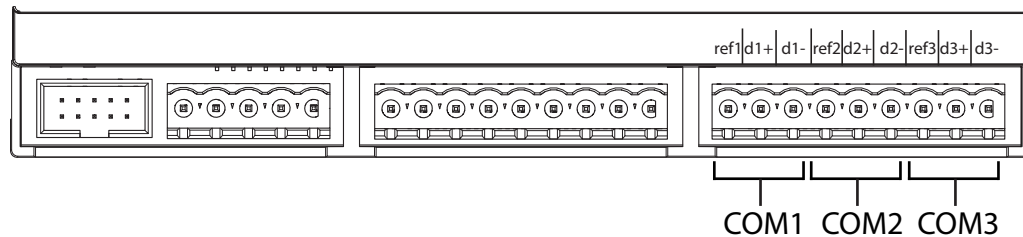

Figure 22 Field bus connections

Table 9 Field Bus Ports

Port	Driver Module	Functional	Optional Driver	Comments
COM1	RS-485	Yes	Yes	See notes 1, 2 and 3
COM2	RS-485	Yes	Yes	
COM3	RS-485	OpenBAS-HV-NX10D only	OpenBAS-HV-NX10D only	

Note 1: P3 and COM3 are functional only on OpenBAS-HV-NX10D.

Note 2: Each of the three P ports allow the field replacement of the RS-485 modules with the OpenBAS-ACC-RS485 optically isolated RS-485 module or OpenBAS-ACC-RS232 conversion module. See section 3.3.1 on page 13.

Note 3: To avoid intermittent communication blackouts, the isolation provided by the OpenBAS-ACC-RS485 module is highly recommended for noisy environments, and to prevent damage to the boards in extreme cases, especially if the OpenBAS-HV-NX10 series controller is inside an enclosure containing high voltage wiring.

4.6.1 OpenBAS-ACC-DB9

OpenBAS-ACC-DB9 is a DB9 adapter which is installed in one of the field bus ports.

4.7 Networking

Figures 23 and 24 show how to add a controller to a network with OpenBAS-NWK-ETH3. Each OpenBAS device must be powered separately.

Connect the SPI port on OpenBAS-NWK-ETH3 to the SPI port on the OpenBAS-HV-NX10 series controller with the included cable, as shown in Figure 23. See section 3.4 on page 17 for information about the SPI port.

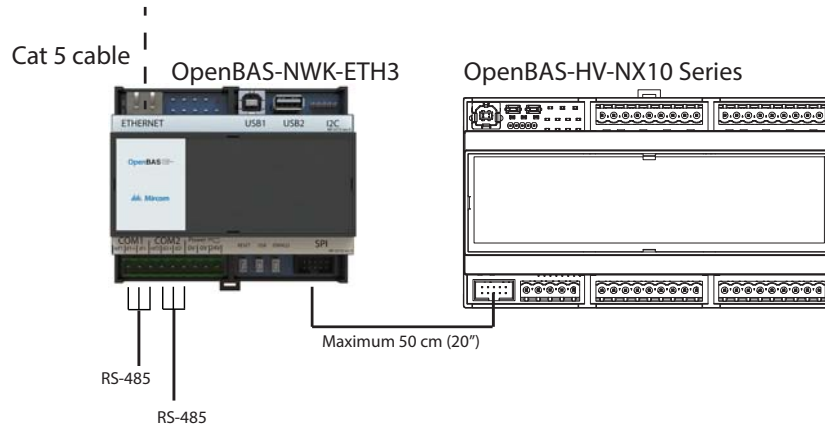

Figure 23 Networking with OpenBAS-NWK-ETH3 with the included cable

OpenBAS-NWK-ETH3 can also connect to one of the RS-485 connections on the OpenBAS-HV-NX10 series controller, as shown in Figures 24 and 25. See section 4.7.1 on page 37 for information on the RS-485 ports.

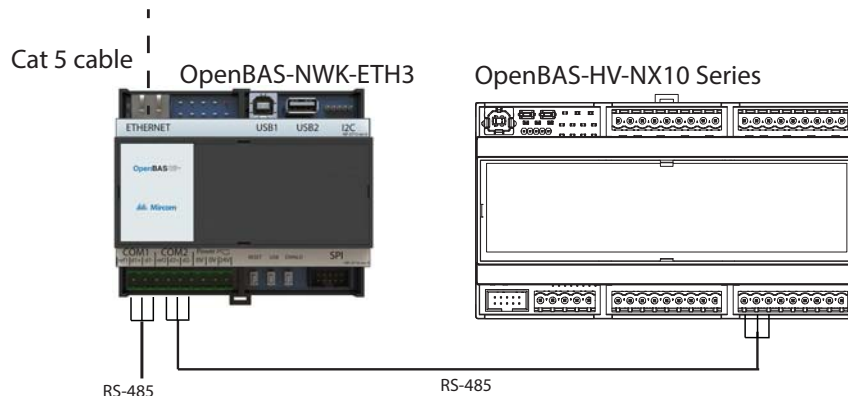

Figure 24 Networking with OpenBAS-NWK-ETH3 over RS-458

4.7.1 RS-485 Details

Figure 25 shows 3 controllers networked with RS-485. The list of supported protocols is in chapter 5.

- 22 AWG twisted pair
- Maximum length: 1219.2 m (4000 feet)
- Mircom recommends shielded cable

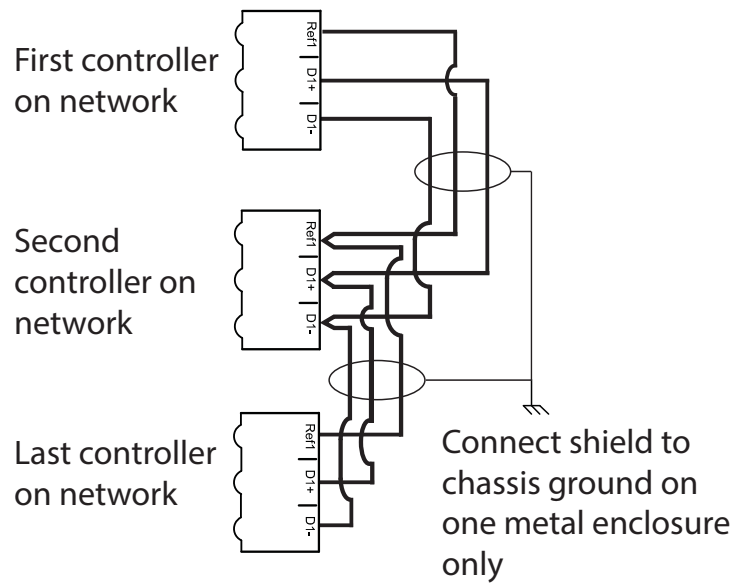

Figure 25 Networking with RS-485

4.8 Connections and LEDs on OpenBAS-HV-HX10D

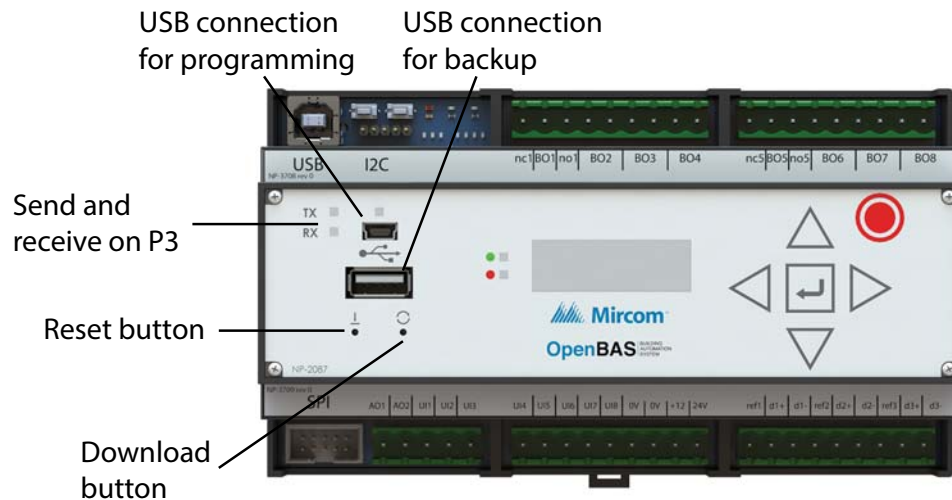

Figure 26 Connections and LEDs on the OpenBAS-HV-NX10D

- USB connection for programming and updating firmware: Connect a computer to this port in order to configure the display.
- USB connection for backup: Connect a USB stick to this port in order to create backups for data trending.
- TX and RX: These LEDs flash to indicate communication through the P3 port (see section 4.6 on page 36).
- Reset button: Press this button to restart the display.
- Download button: Press this button to load firmware on to the controller. Refer to the OpenBAS Programming Manual for information on upgrading controllers.

4.9 Circuit Board LEDs

- PWR: Is red when the unit is powered
- TX and RX: Flash green to indicate communication through ports COM1 and COM2

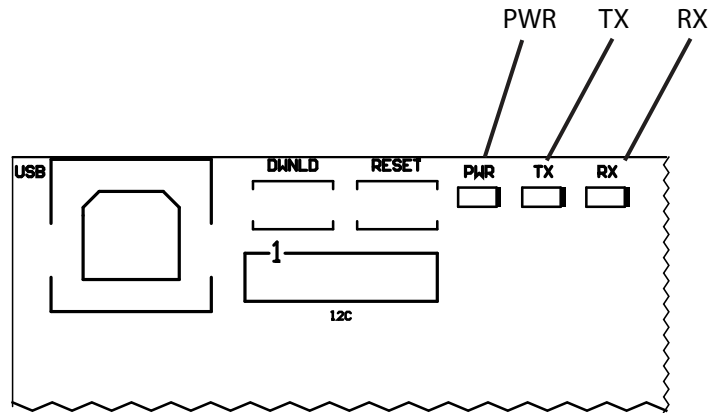

Figure 27 LEDs

5.0 Specifications

Standards:	UL 60730-1		
Input:	12 Vdc, 360 mA max., or 24 Vdc, 450 mA max., or 24 Vac 50/60 Hz, 500 mA max.		
Output:	12 Vdc, 250 mA max. (when 24V powered)		
Power Supply Protection:	Resettable Fuse 1.1 A		
Battery:	FDK Corporation ML2430 Type: lithium Nominal capacity: 100 mAh Nominal voltage: 3 V Mircom part number: BT-025		
Relay Outputs 1 and 5:	Voltage, current	Load	Form
	125 VAC, 5 A	General Use	NO/NC
	28 VDC, 5 A	Resistive	NO/NC
Relay Outputs 2, 3, 4, 6, 7, 8:	Voltage, current	Load	Form
	125 VAC, 5 A	Resistive	NO
	125 VAC, 3 A	General Use	NO
2 Analog Outputs:	Analog Output Voltage: <ul style="list-style-type: none"> • 0-10 VDC • 2-10 VDC • 0-5 VDC 		
8 Universal Inputs:	Analog Inputs: <ul style="list-style-type: none"> • 0-10 VDC • 0-5 VDC • 0.5-4.5 VDC ratiometric • 0-20 mA • 4-20 mA • 1000 Ω temperature sensor • Thermocouple input with x200 amplifiers 		
	Digital (binary) inputs: <ul style="list-style-type: none"> • For dry contacts being fed by 12 VDC 		
	Pulse counters: <ul style="list-style-type: none"> • Active PNP 12 VDC • For dry contacts being fed by 12 VDC 		

Communication Ports:	<p>2 RS-485 ports (3 RS-485 ports on OpenBAS-HV-NX10D) supporting the following protocols:</p> <ul style="list-style-type: none"> • COM1 <ul style="list-style-type: none"> • BACnet/MSTP • Modbus/RTU-Slave • Modbus/RTU-Master • N2-Open • Optomux • COM2 <ul style="list-style-type: none"> • N2-Open • Optomux • N2/O22-master • ASCII • ECM • COM3 (OpenBAS-HV-NX10D only) <ul style="list-style-type: none"> • Modbus/RTU-Slave • N2-Open • Optomux • N2/O22-master • ASCII <p>RS-485 ports can be configured as RS-232 or optically isolated RS-485</p> <p>1 USB 2.0 port supporting the following protocols:</p> <ul style="list-style-type: none"> • Optomux • ASCII <p>2 I²C ports for memory expansion, LCD display, and OpenBAS-HV-RF433R</p> <p>1 SPI port</p> <p>1 port for OpenBAS-HV-CORE2 display</p>
Physical Characteristics:	<p>Weight: 360 g (12.8 oz)</p> <p>Enclosure dimensions: 6 9/32" x 3 35/64" x 2 17/64" (160 mm x 90 mm x 58 mm)</p>
Ambient Conditions:	<p>Operating Temperature: 0° to 40°C (32° to 104°F), 10% to 90% RH noncondensing</p> <p>Indoor Use Only</p>
Purpose of Control:	<p>Operating Control</p>
Construction of Control:	<p>Independently Mounted, for Panel Mount</p>
Action Type and additional features:	<p>Type 1.C</p>
Pollution Degree:	<p>2</p>
Software Class:	<p>Class A</p>
Rated Impulse Voltage:	<p>120V circuits: 2500V</p> <p>24V circuits: 330V</p>

6.0 Warranty and Warning Information

WARNING!

Please read this document **CAREFULLY**, as it contains important warnings, life-safety, and practical information about all products manufactured by the Mircom Group of Companies, including Mircom and Secutron branded products, which shall include without limitation all fire alarm, nurse call, building automation and access control and card access products (hereinafter individually or collectively, as applicable, referred to as “**Mircom System**”).

NOTE TO ALL READERS:

1. **Nature of Warnings.** The within warnings are communicated to the reader out of an abundance of caution and create no legal obligation for Mircom Group of Companies, whatsoever. Without limiting the generality of the foregoing, this document shall NOT be construed as in any way altering the rights and obligations of the parties, governed by the legal documents that apply in any given circumstance.
2. **Application.** The warnings contained in this document apply to all Mircom System and shall be read in conjunction with:
 - a. the product manual for the specific Mircom System that applies in given circumstances;
 - b. legal documents that apply to the purchase and sale of a Mircom System, which may include the company’s standard terms and conditions and warranty statements;
 - c. other information about the Mircom System or the parties’ rights and obligations as may be application to a given circumstance.
3. **Security and Insurance.** Regardless of its capabilities, no Mircom System is a substitute for property or life insurance. Nor is the system a substitute for property owners, renters, or other occupants to act prudently to prevent or minimize the harmful effects of an emergency situation. Building automation systems produced by the Mircom Group of Companies are not to be used as a fire, alarm, or life-safety system.

NOTE TO INSTALLERS:

All Mircom Systems have been carefully designed to be as effective as possible. However, there are circumstances where they may not provide protection. Some reasons for system failure include the following. As the only individual in contact with system users, please bring each item in this warning to the attention of the users of this Mircom System. Failure to properly inform system end-users of the circumstances in which the system might fail may result in over-reliance upon the system. As a result, it is imperative that you properly inform each customer for whom you install the system of the possible forms of failure:

4. **Inadequate Installation.** All Mircom Systems must be installed in accordance with all the applicable codes and standards in order to provide adequate protection. National standards require an inspection and approval to be conducted by the local authority having jurisdiction following the initial installation of the system and following any changes to the system. Such inspections ensure installation has been carried out properly.
5. **Inadequate Testing.** Most problems that would prevent an alarm a Mircom System from operating as intended can be discovered by regular testing and maintenance. The complete system should be tested by the local authority having jurisdiction immediately after a fire, storm, earthquake, accident, or any kind of construction activity inside or outside the premises.

The testing should include all sensing devices, keypads, consoles, alarm indicating devices and any other operational devices that are part of the system.

NOTE TO USERS:

All Mircom Systems have been carefully designed to be as effective as possible. However, there are circumstances where they may not provide protection. Some reasons for system failure include the following. The end user can minimize the occurrence of any of the following by proper training, testing and maintenance of the Mircom Systems:

6. **Inadequate Testing and Maintenance.** It is imperative that the systems be periodically tested and subjected to preventative maintenance. Best practices and local authority having jurisdiction determine the frequency and type of testing that is required at a minimum. Mircom System may not function properly, and the occurrence of other system failures identified below may not be minimized, if the periodic testing and maintenance of Mircom Systems is not completed with diligence and as required.
7. **Improper Operation.** It is important that all system users be trained in the correct operation of the alarm system and that they know how to respond when the system indicates an alarm. A Mircom System may not function as intended during an emergency situation where the user is unable to operate a panic or emergency switch by reason of permanent or temporary physical disability, inability to reach the device in time, unfamiliarity with the correct operation, or related circumstances.
8. **Insufficient Time.** There may be circumstances when a Mircom System will operate as intended, yet the occupants will not be protected from the emergency due to their inability to respond to the warnings in a timely manner. If the system is monitored, the response may not occur in time enough to protect the occupants or their belongings.
9. **Carelessness or Safety Hazards.** Moreover, smoke detectors may not provide timely warning of fires caused by carelessness or safety hazards such as smoking in bed, violent explosions, escaping gas, improper storage of flammable materials, overloaded electrical circuits or children playing with matches or arson.
10. **Power Failure.** Some Mircom System components require adequate electrical power supply to operate. Examples include: smoke detectors, beacons, HVAC, and lighting controllers. If a device operates only by AC power, any interruption, however brief, will render that device inoperative while it does not have power. Power interruptions of any length are often accompanied by voltage fluctuations which may damage Mircom Systems or other electronic equipment. After a power interruption has occurred, immediately conduct a complete system test to ensure that the system operates as intended.
11. **Battery Failure.** If the Mircom System or any device connected to the system operates from batteries it is possible for the batteries to fail. Even if the batteries have not failed, they must be fully charged, in good condition, and installed correctly. Some Mircom Systems use replaceable batteries, which have a limited life-span. The expected battery life is variable and in part dependent on the device environment, usage and type. Ambient conditions such as high humidity, high or low temperatures, or large temperature fluctuations may reduce the expected battery life. Moreover, some Mircom Systems do not have a battery monitor that would alert the user in the event that the battery is nearing its end of life. Regular testing and replacements are vital for ensuring that the batteries function as expected, whether or not a device has a low-battery monitor.
12. **Physical Obstructions.** Motion sensors that are part of a Mircom System must be kept clear of any obstacles which impede the sensors' ability to detect movement. Signals being communicated by a Mircom System may not reach the receiver if an item (such as metal, water, or concrete) is placed on or near the radio path. Deliberate jamming or other inadvertent radio signal interference can also negatively affect system operation.

13. **Wireless Devices Placement Proximity.** Moreover all wireless devices must be a minimum and maximum distance away from large metal objects, such as refrigerators. You are required to consult the specific Mircom System manual and application guide for any maximum distances required between devices and suggested placement of wireless devices for optimal functioning.
14. **Failure to Trigger Sensors.** Moreover, Mircom Systems may fail to operate as intended if motion, heat, or smoke sensors are not triggered.
 - a. Sensors in a fire system may fail to be triggered when the fire is in a chimney, walls, roof, or on the other side of closed doors. Smoke and heat detectors may not detect smoke or heat from fires on another level of the residence or building. In this situation the control panel may not alert occupants of a fire.
 - b. Sensors in a nurse call system may fail to be triggered when movement is occurring outside of the motion sensors' range. For example, if movement is occurring on the other side of closed doors or on another level of the residence or building the motion detector may not be triggered. In this situation the central controller may not register an alarm signal.
15. **Interference with Audible Notification Appliances.** Audible notification appliances may be interfered with by other noise sources such as stereos, radios, televisions, air conditioners, appliances, or passing traffic. Audible notification appliances, however loud, may not be heard by a hearing-impaired person.
16. **Other Impairments.** Alarm notification appliances such as sirens, bells, horns, or strobes may not warn or waken a sleeping occupant if there is an intervening wall or door. It is less likely that the occupants will be alerted or awakened when notification appliances are located on a different level of the residence or premise.
17. **Software Malfunction.** Most Mircom Systems contain software. No warranties are provided as to the software components of any products or stand-alone software products within a Mircom System. For a full statement of the warranties and exclusions and limitations of liability please refer to the company's standard Terms and Conditions and Warranties.
18. **Telephone Lines Malfunction.** Telephone service can cause system failure where telephone lines are relied upon by a Mircom System. Alarms and information coming from a Mircom System may not be transmitted if a phone line is out of service or busy for a certain period of time. Alarms and information may not be transmitted where telephone lines have been compromised by criminal tampering, local construction, storms or earthquakes.
19. **Component Failure.** Although every effort has been made to make this Mircom System as reliable as possible, the system may fail to function as intended due to the failure of a component.
20. **Integrated Products.** Mircom System might not function as intended if it is connected to a non-Mircom product or to a Mircom product that is deemed non-compatible with a particular Mircom System. A list of compatible products can be requested and obtained.

Warranty

Purchase of all Mircom products is governed by:

<https://www.mircom.com/product-warranty>

<https://www.mircom.com/purchase-terms-and-conditions>

<https://www.mircom.com/software-license-terms-and-conditions>



CANADA - Main Office
25 Interchange Way
Vaughan, ON L4K 5W3
Tel: (905) 660-4655
(888) 660-4655
Fax: (905) 660-4113

U.S.A
4575 Witmer Industrial Estates
Niagara Falls, NY 14305
Tel: (905) 660-4655
(888) 660-4655
Fax: (905) 660-4113

© Mircom 2017
Printed in Canada
Subject to change without prior notice

www.mircomgroup.com