

OpenBAS

BUILDING
AUTOMATION
SYSTEM

OpenBAS-PM-ME11

Power Meter



Table of Contents

1.0	Introduction	6
1.1	OpenBAS-PM-ME11 Power Meter	6
1.2	Features	6
2.0	Overview	7
2.1	OpenBAS-PM-ME11 Components	7
2.1.1	Controllers	7
2.1.2	Compatible Modules	7
3.0	Installation	8
3.1	Parts of the Enclosure	8
3.2	Controller Board Connections	11
3.3	Jumpers J1, J2, J3, J4	11
3.4	USB	12
3.5	Battery	13
3.6	Enclosure Dimensions	14
3.7	Assembly	15
3.8	Mounting the Enclosure	16
4.0	Field Wiring	17
4.1	Wiring Requirements	17
4.1.1	Required Tools	17
4.1.2	Installation Tips	17
4.2	Power Supply Connection	18
4.3	High Voltage and Current Transformer Wiring	19
4.3.1	Wiring Setups	20
4.3.2	Breaker (As Applicable)	21
4.3.3	Fuses (As Applicable)	22
4.3.4	Wiring 5 A Secondary Current Transformers	23
4.4	Field Bus Connection	24
4.5	LEDs, Switches, and Buttons	25
5.0	Specifications	26
6.0	Master Warranty and Warning Information	27

List of Figures

Figure 1	Parts of the enclosure	8
Figure 2	Tabs on enclosure	9
Figure 3	Lift tabs and remove circuit board	10
Figure 4	Board connections	11
Figure 5	Enclosure (back view)	14
Figure 6	Fit the circuit board into the enclosure	15
Figure 7	Enclosure mounted on DIN rail	16
Figure 8	Enclosure mounted on DIN rail (back view)	16
Figure 9	Power supply (24 VAC or 24 VDC) and COM terminals	18
Figure 10	High voltage line terminals	19
Figure 11	Current transformer terminals	19
Figure 12	High Voltage and Current Transformer Wiring with Thermomagnetic Breaker	21
Figure 13	High Voltage Wiring with Fuses	22
Figure 14	Resistor on current transformer when the secondary of the current transformer is 5 A .	23
Figure 15	Networking with RS-485	24
Figure 16	LEDs and buttons on the top of the circuit board	25
Figure 17	LEDs on the bottom of the circuit board	25

List of Tables

Table 1	OpenBAS-PM-ME11 Controllers	7
Table 2	OpenBAS-PM-ME11 Compatible Modules	7
Table 3	Jumpers and CT Terminals	11
Table 4	OpenBAS-PM-ME11 Jumper Settings	12

1.0 Introduction

This document provides information on installing the OpenBAS-PM-ME11 Power Meter.

1.1 OpenBAS-PM-ME11 Power Meter

Mircom's OpenBAS-PM-ME11 Power Meter is a high voltage three phase power meter with energy quality analyzer. It keeps monthly records for up to one year of energy consumption and has a field bus interface with RS-485 and support for multiple protocols.

The OpenBAS-PM-ME11 can be installed in main power substations, emergency generators, step up or step down transformers, and power panels. It supports one, two or three phase systems in three or four wire configurations. It can measure the power of systems up to 600 V. It uses any kind of standard current transformer, either closed or split core, with secondary currents of:

- 5 A (with the addition of external burden resistors)
- 1 A
- 500 mA
- 250 mA
- 100 mA

1.2 Features

The OpenBAS-PM-ME11 integrates into Mircom's unified platform for automating HVAC and mechanical rooms as well as incorporating energy management features and lighting control to offer building owners and managers a seamless operation with the following features:

- Modular design to cover any small, medium or large project.
- Industry standard field bus protocols to integrate into any existing BAS system such as: BACnet, Modbus, Optomux, N2-Open, and ASCII.
- Connects to the OpenBAS-NWK-ETH3 controller for integration into IP networks and uses the most advanced features and protocols such as distributed computing, USB and Cloud storage, HTML5, JavaScript, XML, Ajax, SMS, and GSM.
- Modular add-ons for every Building Automation System solution.
- The OpenBAS software which provides owners and managers a single solution for managing all their building's automation needs.



Caution: Consult this document to learn about potential hazards. Hazards are marked on the controller with the symbol on the left.

2.0 Overview

2.1 OpenBAS-PM-ME11 Components

2.1.1 Controllers

Table 1 OpenBAS-PM-ME11 Controllers

Picture	Model	Description
	OpenBAS-PM-ME11	The OpenBAS-PM-ME11 is a high voltage three phase power meter with energy quality analyzer. It stores up to 12 months of data and has a field bus interface with RS-485 and support for multiple protocols.

2.1.2 Compatible Modules

Compatible modules are mounted separately from the controller.

Table 2 OpenBAS-PM-ME11 Compatible Modules

Model	Description
OpenBAS-NWK-ETH3	Ethernet controller and gateway with support for multiple protocols <ul style="list-style-type: none"> • 2 field bus connections • Mounts in a DIN rail-mounted box • Powered separately

3.0 Installation



Attention: Installation of OpenBAS-PM-ME11 controllers should be in accordance with the Canadian Electrical Code or the National Electrical Code, and comply with all local regulations. Final acceptance is subject to the Local Authority Having Jurisdiction (AHJ).

If this equipment is used in a manner not specified by the manufacturer, the protection provided by the equipment may be impaired.

The safety of any system incorporating this equipment is the responsibility of the assembler of the system.



Note: In case of malfunction or damage, do not make any attempts at repair.

Do not dismantle this product.

This product does not require cleaning and should not be cleaned.

3.1 Parts of the Enclosure

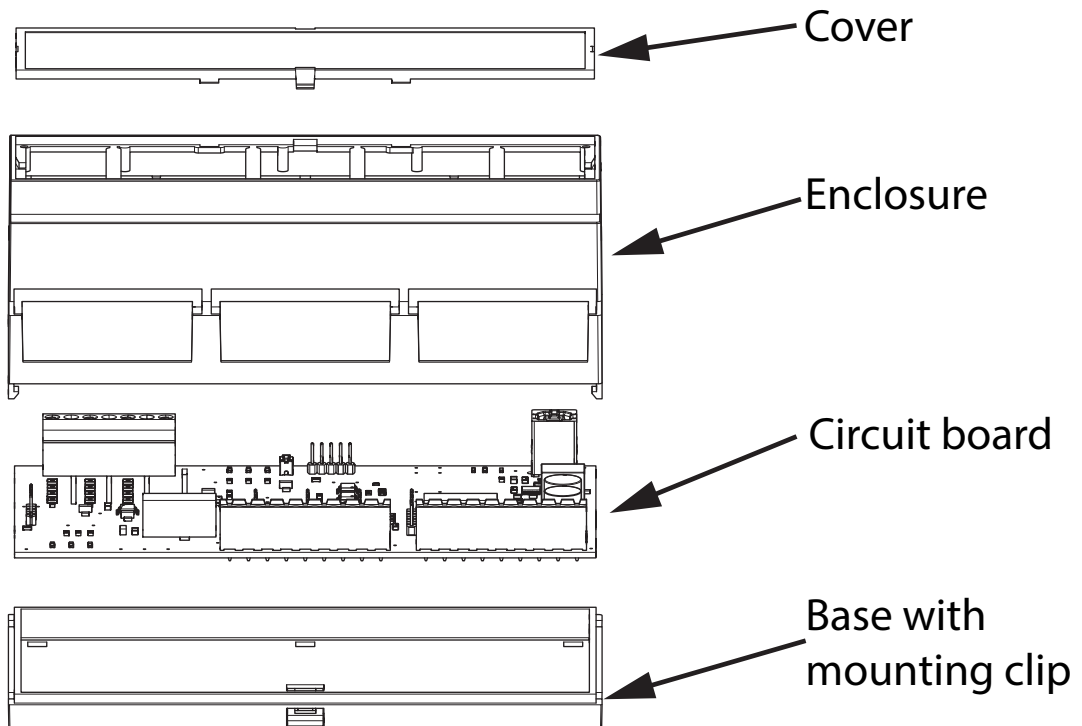

Figure 1 Parts of the enclosure

To remove the circuit board from the enclosure



Caution: Risk of Electric Shock. Disconnect the mains power and disconnect the controller from all wiring before opening the enclosure. The controller could be connected to 600 V and opening it while connected could result in electric shock.



Attention: Always hold circuit boards by the edges to prevent damage from static electricity. Always wear an anti-static bracelet when handling circuit boards.

1. Remove the cover.
2. Insert a flathead screwdriver under the tabs on the enclosure, shown in Figure 2, in order to lift the tabs and remove the base.

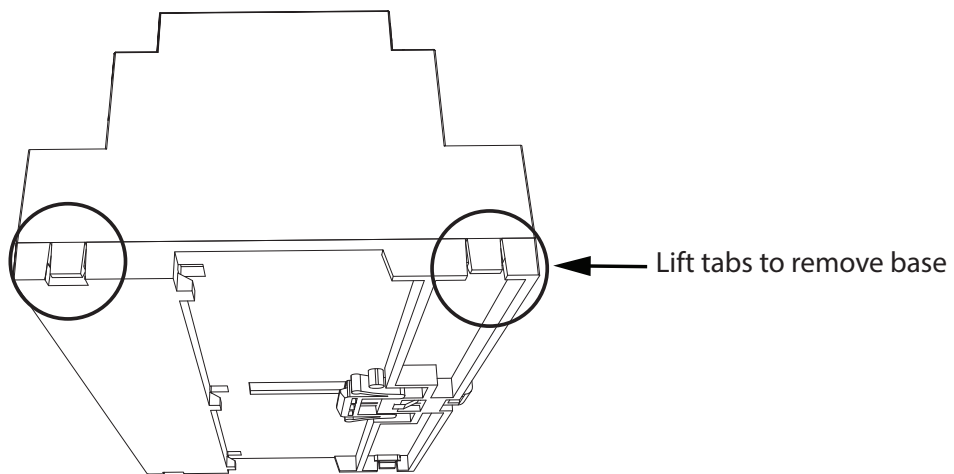

Figure 2 Tabs on enclosure

3. Hold the circuit board with one hand, and with the other hand lift the tabs so that you can remove the circuit board from the enclosure. See Figure 3.

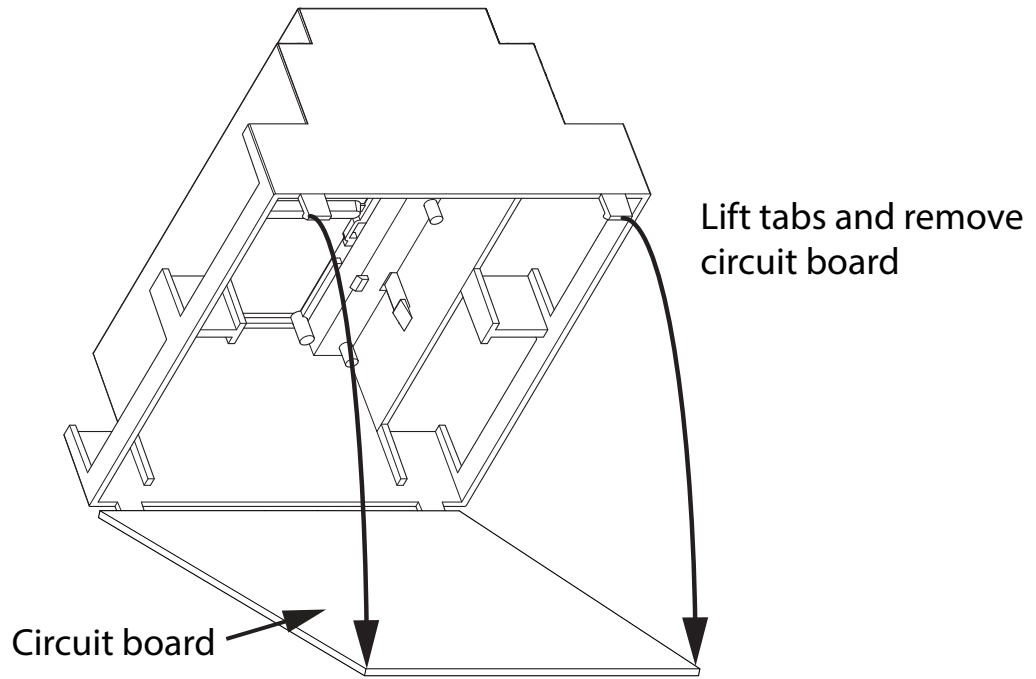

Figure 3 Lift tabs and remove circuit board



Attention: Be careful not to break the tabs. Do not apply excessive force.

3.2 Controller Board Connections



Attention: This job must be performed only by a certified technician as dangerous voltages might be present inside of the enclosure. Always disconnect the power before installing accessories.

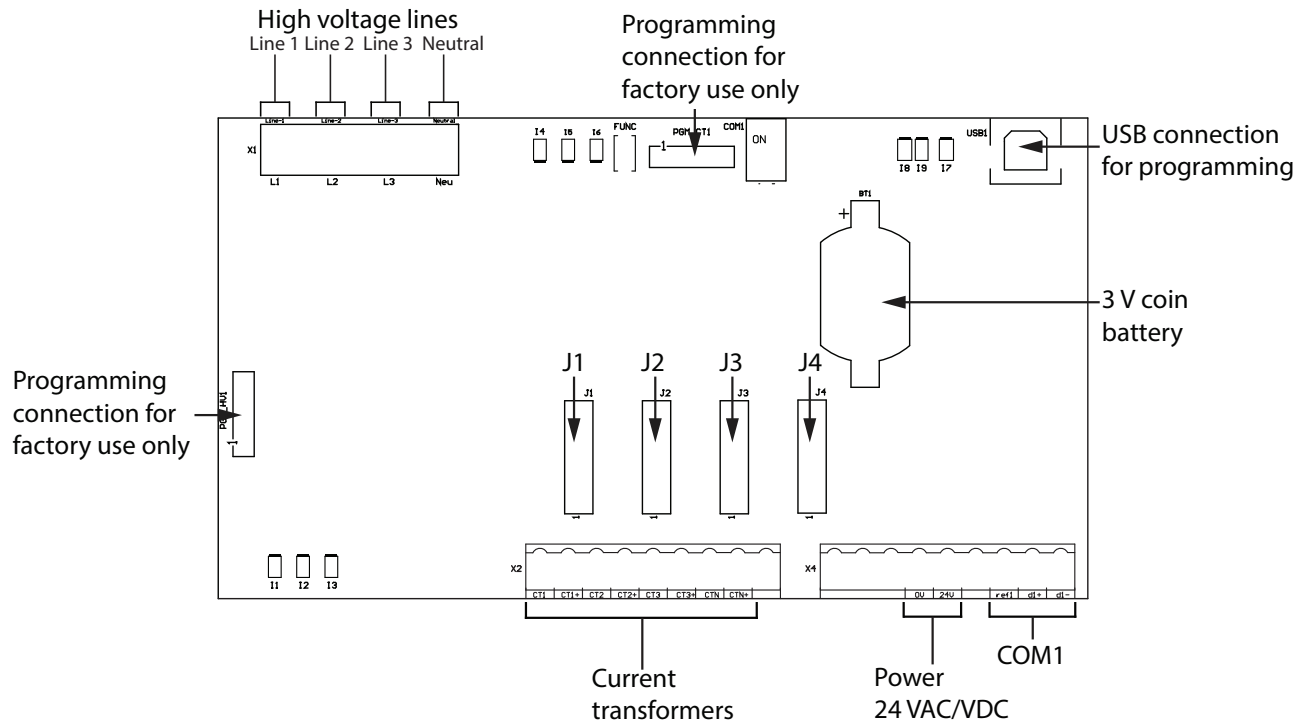

Figure 4 Board connections

3.3 Jumpers J1, J2, J3, J4

Each set of jumpers controls a pair of CT terminals, as shown in Table 3.

Table 3 Jumpers and CT Terminals

Set of Jumpers	CT Terminals
J1	CT1 and CT1+
J2	CT2 and CT2+
J3	CT3 and CT3+
J4	CTN and CTN+

Table 4 shows how to set the jumpers depending on the secondary current of the corresponding current transformer. There are 7 pins and pin 1 is on the bottom.

For example, if you connect a current transformer with a secondary current of 1 A to CT2, then connect the pins of J2 in the pairs 1+2, 3+4, and 6+7.

If the current falls between one of the ranges in Table 4, then use the next highest number. For example, if you connect a current transformer with a secondary current of 300 mA to CT3, then use the 500 mA setting: connect the pins of J3 in the pairs 3+4 and 6+7.

Table 4 OpenBAS-PM-ME11 Jumper Settings

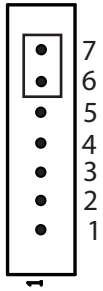
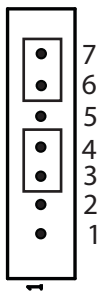
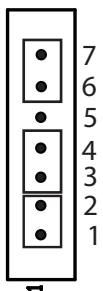
Maximum Secondary Current of Current Transformer	Jumper Setting
100 mA	No jumpers
250 mA	 <p>6+7</p>
500 mA	 <p>3+4 and 6+7</p>
1 A	 <p>1+2 and 3+4 and 6+7</p>
5 A	No jumpers and an external 0.2 Ω, 5 W 1% load resistor in parallel with the current transformer. See section 4.3.4 on page 23.

3.4 USB

The full speed USB 2.0 connection is shown in Figure 4. Connect a computer to this port in order to configure the controller.

3.5 Battery



Caution: **Risk of Electric Shock.** Disconnect the mains power and open the mains breaker before making connections to the OpenBAS-PM-ME11. The controller could be connected to 600 V and opening it while connected could result in electric shock.

The 3 V CR2032 battery is used only during power outages for real time clock and data retention. The Mircom part number is BT-007.

Install the battery before mounting the controller.



Attention: **Caution – The battery used in this device may present a risk of fire or chemical burn if mistreated. Do not disassemble, heat above 60°C (140°F), or incinerate. Replace battery with 3-3.3 V CR2032 10 mA maximum abnormal charging current only. Use of another battery may present a risk of fire or explosion.**

To install or replace the battery

1. Disconnect the mains power and open the mains breaker.
2. Disconnect all wiring from the unit.
3. Remove the top cover.
4. Disconnect the old battery.
5. Dispose of the used battery promptly. Keep away from children. Do not disassemble and do not dispose of in fire.
6. Connect the new battery to the connector shown in Figure 4.



Note: Pay attention to polarity. The positive side is on top.

3.6 Enclosure Dimensions

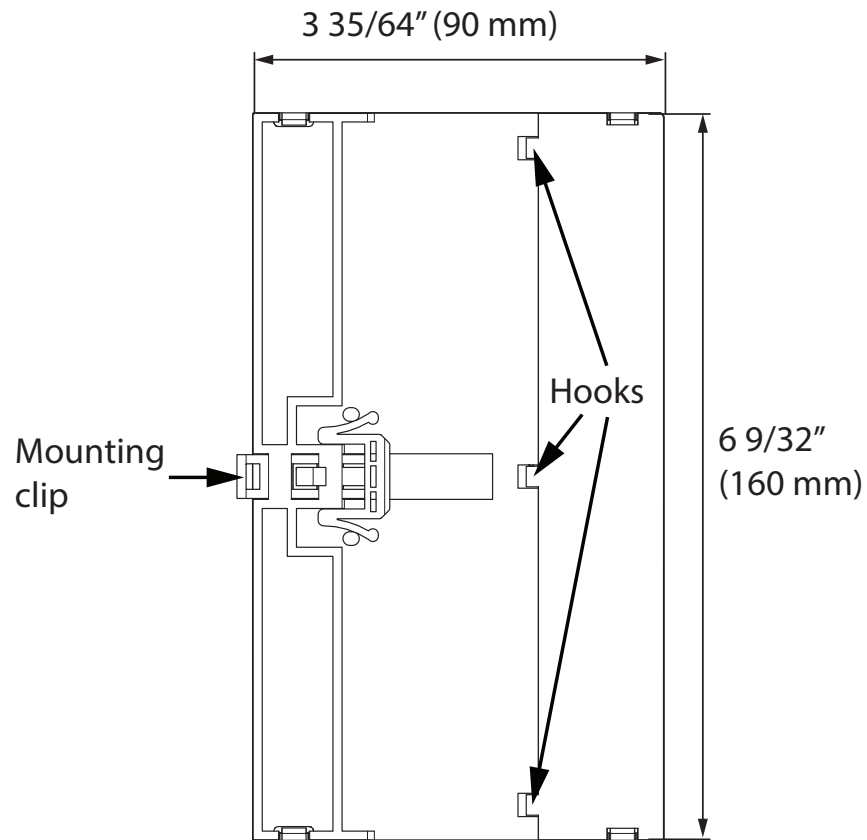

Figure 5 Enclosure (back view)

3.7 Assembly

To put the circuit board in the enclosure

1. Hold the circuit board with one hand, and with the other hand lift the tabs so that you can fit the circuit board into the enclosure as shown below.



Note: Make sure that the board is the right way up: the terminal labels on the enclosure must match the terminal labels on the circuit board.

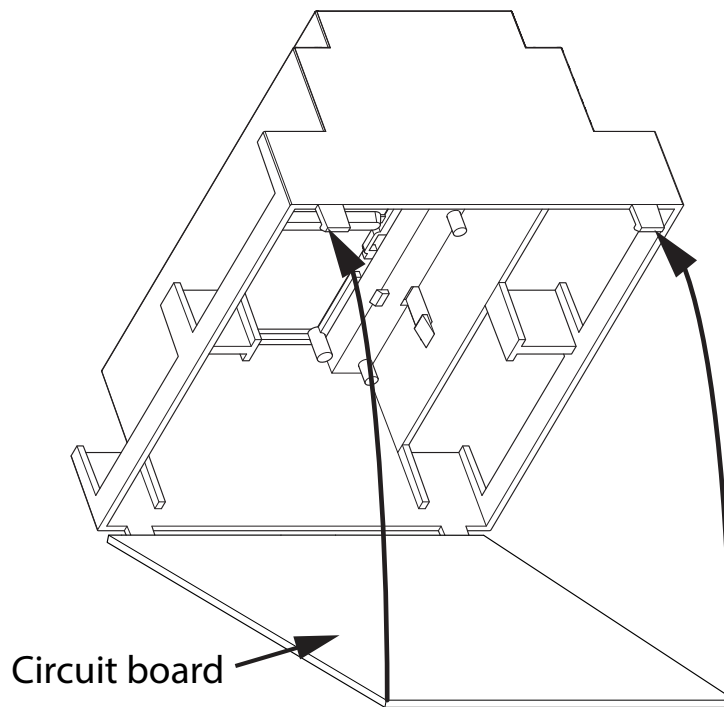

Figure 6 Fit the circuit board into the enclosure

2. Lift the other side of the circuit board so that it fits under the 2 remaining tabs.
3. Snap the base onto the enclosure. Make sure that the mounting clip is on the bottom.
4. Snap the cover onto the enclosure. Make sure that the Mircom logo is the right way up.



Attention: Always hold circuit boards by the edges to prevent damage from static electricity. Always wear an anti-static bracelet when handling circuit boards.

3.8 Mounting the Enclosure



Attention: Mount the enclosure on a DIN rail in a UL-compliant metal box. Do not drill holes in the enclosure or modify the enclosure in any way.

The OpenBAS-PM-ME11 may not be installed in a panel where it exceeds 75% of the wiring space of any cross-sectional area within the panel.

To mount the enclosure on a DIN rail

Mount so that the terminal labels are the right way up and the mounting clip is on the bottom.

1. Mount a section of DIN rail so that there is enough space for the enclosure to be mounted.
2. Slide the hooks under the rail and push the enclosure to secure it on the DIN rail. The mounting clip locks it in place.

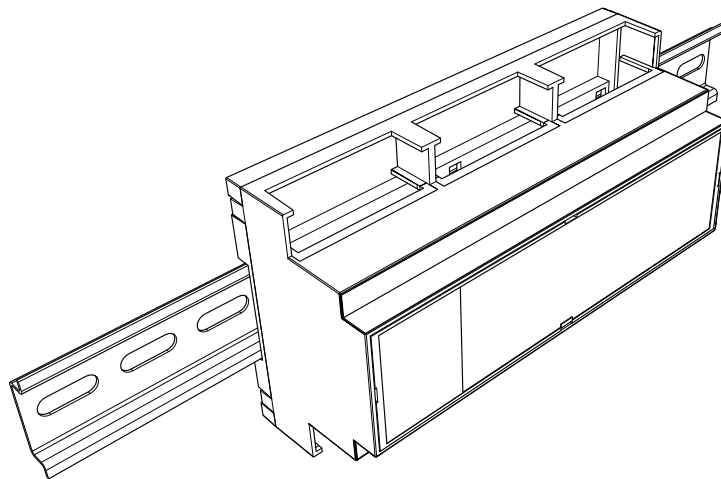

Figure 7 Enclosure mounted on DIN rail (circuit board not shown)

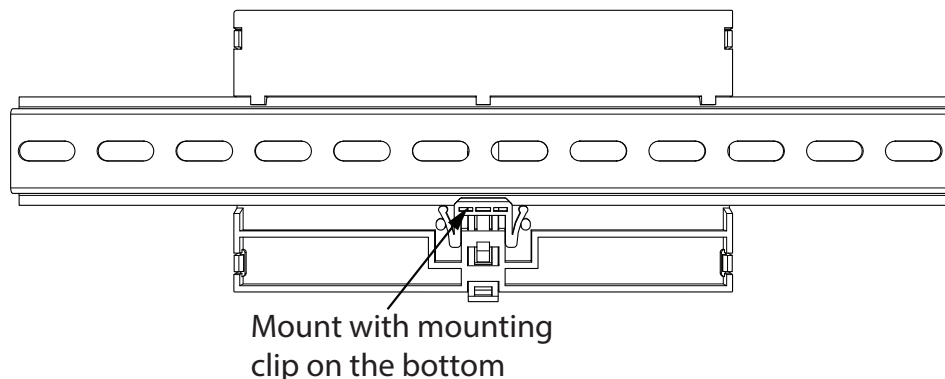

Figure 8 Enclosure mounted on DIN rail (back view)

To remove the enclosure from the DIN rail

- With your hands or with a small flathead screwdriver, pull the mounting clip to release the enclosure from the DIN rail, and carefully pull the enclosure off the DIN rail.

4.0 Field Wiring



Caution: **Risk of Electric Shock.** Disconnect the mains power before making connections to the OpenBAS-PM-ME11.



Caution: Installation of OpenBAS-PM-ME11 controllers must be in accordance with the Canadian Electrical Code or the National Electrical Code, and comply with all local regulations. Appropriate wiring and conduit should be used in compliance with local regulations. Final acceptance is subject to the Local Authority Having Jurisdiction (AHJ).

Due to the high voltages present only certified technicians should install and service the power meter.

An appropriate UL listed class 2 power supply or transformer with necessary protection devices such as fuses or breakers should be used to limit the risk of fire.



Attention: **If this equipment is used in a manner not specified by the manufacturer, the protection provided by the equipment may be impaired.**

4.1 Wiring Requirements

Figure 4 on page 11 shows the location of the terminals. The terminals are depluggable for ease of wiring.

For all terminals except the high voltage terminals, use twisted pair copper wire, 12-24AWG, stripped to 7-8mm and torqued to 0.5 Nm max.

The high voltage terminals require 12 AWG wire with a required torque of 0.79 Nm.

Wiring for high voltage metering must comply with the local electric codes.

4.1.1 Required Tools

Tools needed:

- Precision or jeweler's screwdriver set
- Wire cutter
- Wire stripper

4.1.2 Installation Tips

- Perform visual inspection of circuit board and parts for obvious issues.
- Use a wire tie to group wires for easy identification and neatness.

4.2 Power Supply Connection



Caution: Risk of Electric Shock. Disconnect the mains power and open the mains breaker before making connections to the OpenBAS-PM-ME11.

The power meter should have its own power supply.

- 24 Vac 50/60Hz, or 24 Vdc, 250mA max.

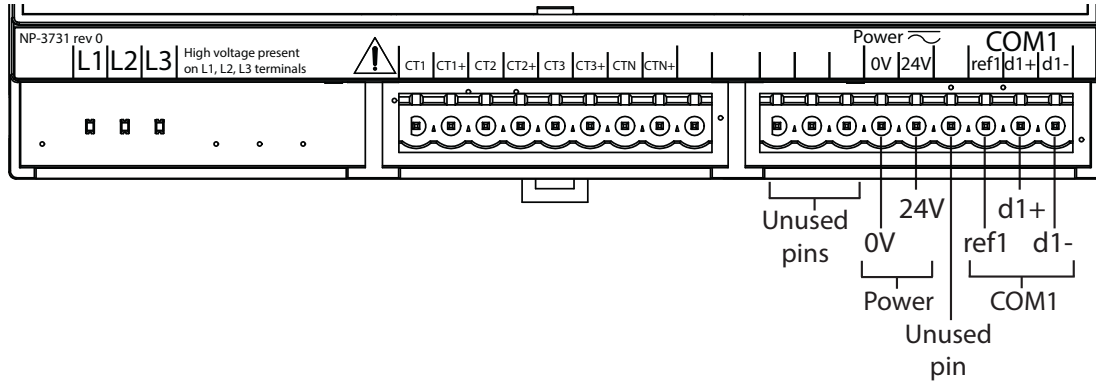

Figure 9 Power supply (24 VAC or 24 VDC) and COM terminals

4.3 High Voltage and Current Transformer Wiring



Note: Use 'UL Listed' Energy Monitor Current Transformers.

Connect 18 AWG min., 600 V min. insulated wiring for Line voltages and Neutral to the appropriate locations in the breaker panel, in accordance with all national and local electrical codes.

The neutral of the mains supply system monitored by the OpenBAS-PM-ME11 must be earthed.



Caution: **Risk of Electric Shock.** Disconnect the mains power and open the mains breaker before making connections to the OpenBAS-PM-ME11.

The high voltage line terminals and current transformer terminals are shown in Figures 10 and 11.

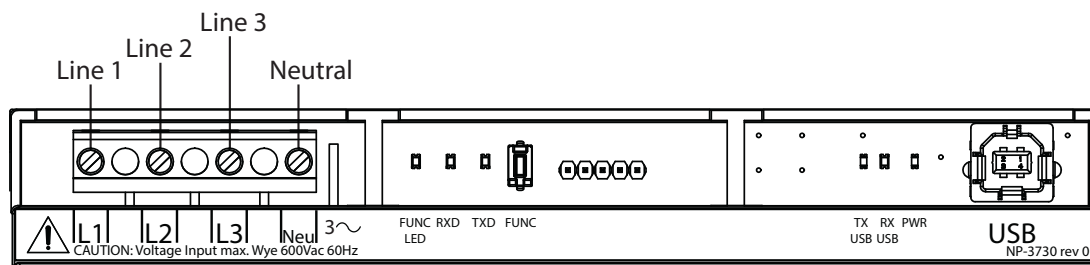

Figure 10 High voltage line terminals

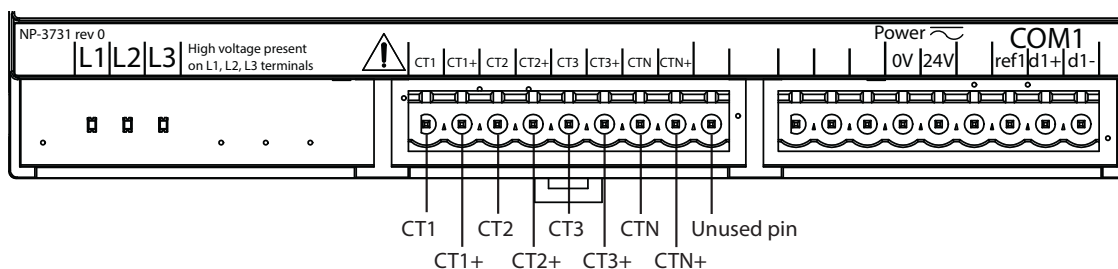

Figure 11 Current transformer terminals

4.3.1 Wiring Setups

To ensure correct wiring, use one of the following setups:

- **1 phase system.** Connect two wires: L1 phase + neutral
- **2 phase system.** Connect three wires: L1 + L2 phases + neutral
- **3 phase system.** Connect four wires: L1 + L2 + L3 phases + neutral (this is the preferred setup)
- **3 phase system.** Connect three wires: L1 + L2 + L3 phases only, and leave neutral floating. This setup works only for three phase systems that have a voltage balance between lines of 5% or better. If any of the three phases drop or are left unconnected, then the measurements will be incorrect.



Attention: Match each CT terminal with its corresponding voltage measuring line, as shown in Figures 12 and 13.

Use either a thermomagnetic breaker or fuses to protect the high voltage wiring. Section 4.3.2 describes the breaker and Section 4.3.3 describes the fuses.

4.3.2 Breaker (As Applicable)

Install a disconnecting device such as a switch or circuit breaker in case of emergency. The breaker must be a suitable three phase thermomagnetic breaker with the appropriate protection rating for the installed system.

- Mark the disconnecting devices as the disconnecting device for the OpenBAS-PM-ME11.
- Mount the OpenBAS-PM-ME11 within reach of the disconnecting device in an area with adequate ventilation.
- Do not position the disconnecting device so that it is difficult to operate the disconnecting device.

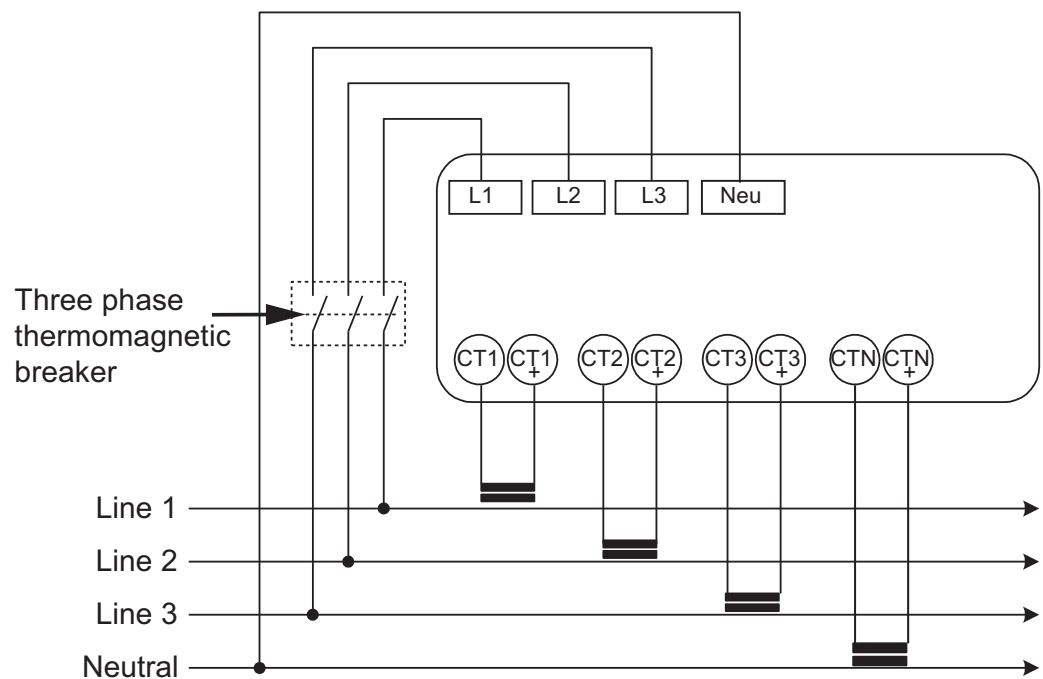

Figure 12 High Voltage and Current Transformer Wiring with Thermomagnetic Breaker

4.3.3 Fuses (As Applicable)

The fuses must be 600 V, 1 to 5 A, three phase fuses installed in compliance with local regulations.

Each high voltage line terminal on the OpenBAS-PM-ME11 can receive a maximum of 600 VAC.

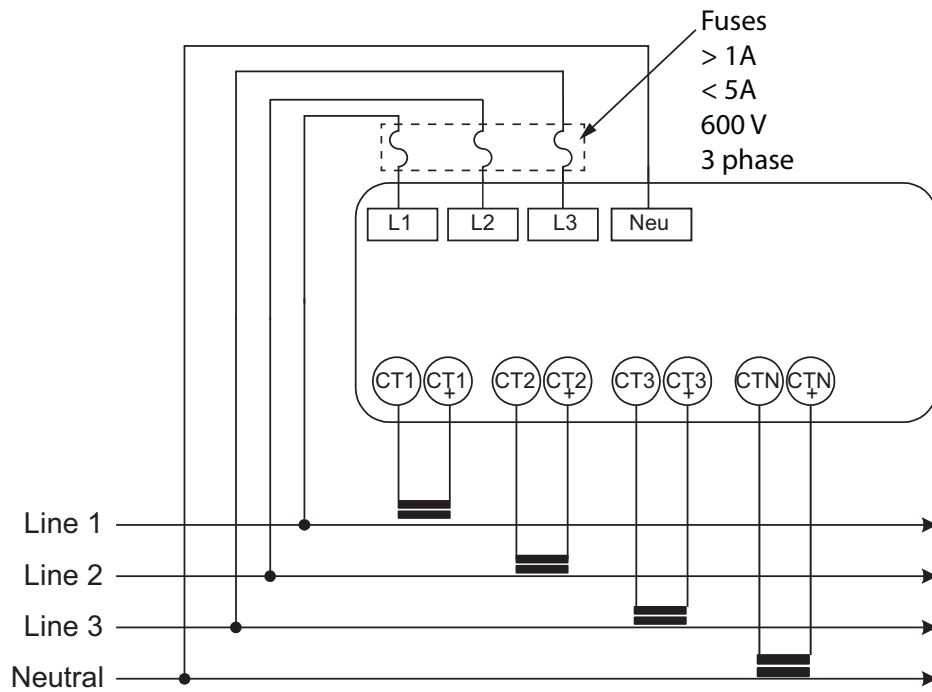

Figure 13 High Voltage Wiring with Fuses

4.3.4 Wiring 5 A Secondary Current Transformers

If the secondary of the current transformer is 5 A, remove all jumpers from the corresponding jumper set (section 3.3) and install a 0.2 Ω, 5 W 1% load resistor in parallel as shown in Figure 14.



Attention: Not installing this resistor on a current transformer with a 5 A secondary will damage the OpenBAS-PM-ME11.

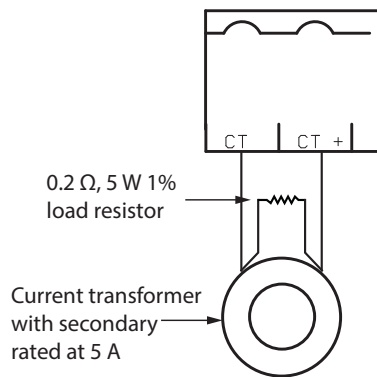

Figure 14 Resistor on current transformer when the secondary of the current transformer is 5 A

4.4 Field Bus Connection

The RS-485 field bus connection is labeled COM1 and is shown in Figure 9. Figure 15 shows 3 controllers networked together. The list of supported protocols is in chapter 5.

- 22 AWG twisted pair
- Maximum length: 1219.2 m (4000 feet)
- Mircom recommends shielded cable

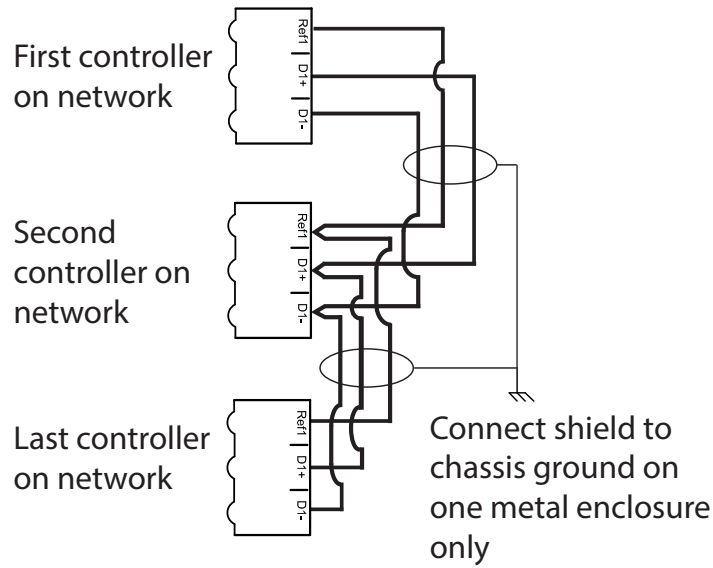

Figure 15 Networking with RS-485

4.5 LEDs, Switches, and Buttons

- RXD, TXD: Indicate RS-485 communication.
- Function button and Function LED: Temporarily switches the protocol to ASCII.
- Programming DIP switch: Leave switches 1 and 2 ON during normal operation.
- PWR: Is red when the unit is powered.
- TX1 USB and RX USB: Flash to indicate communication through the USB port.
- Power: Illuminates steady when the unit is powered on.

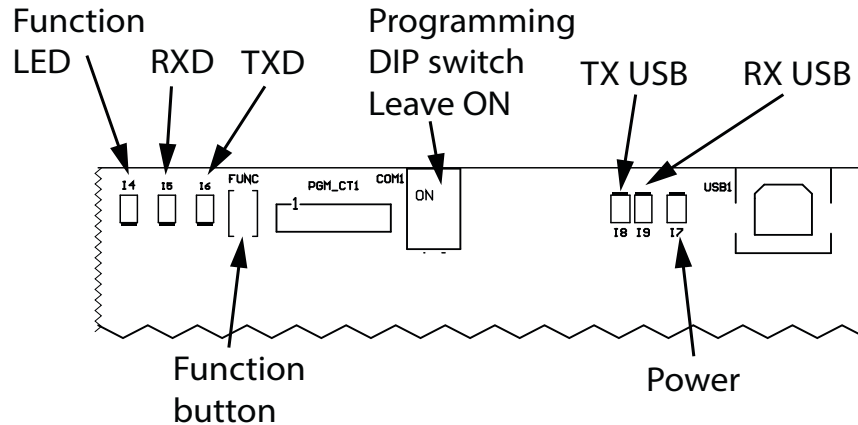

Figure 16 LEDs and buttons on the top of the circuit board

- L1, L2 L3: These LEDs are on when the high voltage LINE inputs are receiving 24 VAC or more.

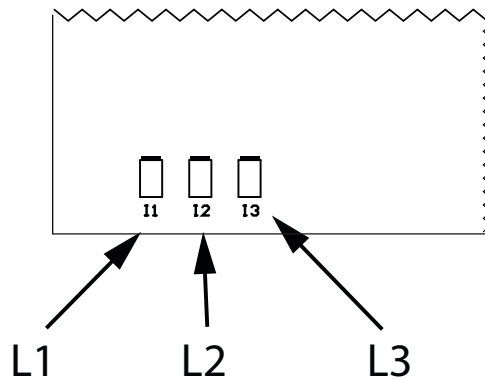



Figure 17 LEDs on the bottom of the circuit board

5.0 Specifications

Standards:	UL 61010-1, 3rd Edition, May 11, 2012, Revised July 15 2015 CAN/CSA-C22.2 No. 61010-1-12, 3rd Edition, Revision dated July 2015 IEC 61010-1:2010 (Third Edition) IEC/EN 61010-1:2010 (Third Edition)
Input:	 24 Vac 50/60Hz, or 24 Vdc, 250mA max. Overvoltage Category II Mains supply voltage fluctuations not to exceed ± 10 percent of the nominal voltage
Battery:	Type: CR2032 3 V - 3.3 V, maximum abnormal charging current: 10 mA Mircom part number: BT-007
Power Supply Protection:	Resettable fuse 0.30 A
High Voltage Terminals:	<ul style="list-style-type: none"> • 600 V max. • Single phase, 2 phase, or 3 phase
Current Transformer Terminals:	<ul style="list-style-type: none"> • Measurement Category CAT III • 1 A max. or 5 A with the addition of external burden resistors
Communication Ports:	1 RS-485 port supporting the following protocols: <ul style="list-style-type: none"> • BACnet/MSTP • Modbus/RTU-Slave • N2-Open • Optomux • ASCII 1 USB 2.0 port for programming supporting the following protocols: <ul style="list-style-type: none"> • BACnet/MSTP • Modbus/RTU-Slave • N2-Open • Optomux • ASCII Note: The RS-485 port and the USB port cannot be used at the same time
Physical Characteristics:	Weight: 0.18 kg (0.40 lb) Enclosure dimensions: 160 mm x 90 mm x 58 mm (6 9/32" x 3 35/64" x 2 17/64")
Ambient Conditions:	Minimum temperature rating of the cable to be connected to the field wiring terminals: 75 °C (167°F) Operating Temperature: 0° to 40°C (32° to 104°F) Maximum Relative Humidity: 80 percent for temperatures up to 31°C decreasing linearly to 50 percent relative humidity at 40°C Indoor Use Only
Mounting:	The OpenBAS-PM-ME11 may not be installed in a panel where it exceeds 75% of the wiring space of any cross-sectional area within the panel Mount the enclosure on a DIN rail in a UL-compliant metal box
Altitude:	Altitude is evaluated for up to 2000 m
Cleaning:	This product does not require cleaning and should not be cleaned
Pollution Degree:	2

6.0 Master Warranty and Warning Information

Terms & Interpretation

In this document the term **MGC System** refers to all fire alarm, nurse call, and building automation products manufactured by Mircom Group of Companies, Mircom Technologies Ltd., MGC Systems Corp or subsidiaries and affiliates and includes specific systems such as MiCare™, OpenBAS™, and FlexNet™. Moreover, the term **MGC System** extends to cover all component parts and software used within such products.

Warning Please Read Carefully

All **MGC Systems** are subject to terms and conditions of sale as follows:

Note to Installers

This warning contains vital information. As the only individual in contact with system users, it is your responsibility to bring each item in this warning to the attention of the users of this MGC System. Failure to properly inform system end-users of the circumstances in which the system might fail may result in over-reliance upon the system. As a result, it is imperative that you properly inform each customer for whom you install the system of the possible forms of failure.

System Failures

All **MGC Systems** have been carefully designed to be as effective as possible. However, there are circumstances where they may not provide protection. Some reasons for system failure include:

Inadequate Installation

All **MGC Systems** must be installed in accordance with all the applicable codes and standards in order to provide adequate protection. National standards require an inspection and approval to be conducted by the Local Authority Having Jurisdiction following the initial installation of the system and following any changes to the system. Such inspections ensure installation has been carried out properly.

Inadequate Testing

Most problems that would prevent an alarm a **MGC System** from operating as intended can be discovered by regular testing and maintenance. The complete system should be tested by the Local Authority Having Jurisdiction immediately after a fire, storm, earthquake, accident, or any kind of construction activity inside or outside the premises. The testing should include all sensing devices, keypads, consoles, alarm indicating devices and any other operational devices that are part of the system.

IMPORTANT NOTE: End-users of the system must take care to ensure that the system, batteries, telephone lines, etc. are tested and examined on a regular basis to minimize system failure.

System Users

It is important that all system users be trained in the correct operation of the alarm system and that they know how to respond when the system indicates an alarm.

A **MGC System** may not function as intended during an emergency situation where the user is unable to operate a panic or emergency switch by reason of permanent or temporary physical disability, inability to reach the device in time, unfamiliarity with the correct operation, or related circumstances.

Insufficient Time

There may be circumstances when a **MGC System** will operate as intended, yet the occupants will not be protected from the emergency due to their inability to respond to the warnings in a timely manner. If the system is monitored, the response may not occur in time enough to protect the occupants or their belongings.

Moreover, smoke detectors may not provide timely warning of fires caused by carelessness or safety hazards such as smoking in bed, violent explosions, escaping gas, improper storage of flammable materials, overloaded electrical circuits, children playing with matches or arson.

Power Failure

Some **MGC System** components require adequate electrical power supply to operate. Examples include: smoke detectors, beacons, HVAC, and lighting controllers. If a device operates only by AC power, any interruption, however brief, will render that device inoperative while it does not have power. Power interruptions of any length are often accompanied by voltage fluctuations which may damage **MGC Systems** or other electronic equipment. After a power interruption has occurred, immediately conduct a complete system test to ensure that the system operates as intended.

Battery Failure

If the **MGC System** or any device connected to the system operates from batteries it is possible for the batteries to fail. Even if the batteries have not failed, they must be fully charged, in good condition, and installed correctly.

MGC Systems with wireless transmitters use replaceable batteries. The system is designed to provide several years of battery life under normal conditions. The expected battery life is a function of the device environment, usage and type. Ambient conditions such as high humidity, high or low temperatures, or large temperature fluctuations may reduce the expected battery life. While each transmitting device has a low battery monitor which identifies when the batteries need to be replaced, this monitor may fail to operate as expected. Regular testing and maintenance will keep the system in good operating condition.

Physical Obstructions

Motion sensors that are part of a **MGC System** must be kept clear of any obstacles which impede the sensors' ability to detect movement. Signals being communicated by a **MGC System** may not reach the receiver if an item (such as metal, water, or concrete) is placed on or near the radio path. Deliberate jamming or other inadvertent radio signal interference can also negatively affect system operation.

Moreover, **MGC Systems** may fail to operate as intended if motion, heat, or smoke sensors are not triggered. Sensors in a fire system may fail to be triggered when the fire is in a chimney, walls, roof, or on the other side of closed doors; and, smoke and heat detectors may

not detect smoke or heat from fires on another level of the residence or building. In this situation the control panel may not alert occupants of a fire.

Sensors in a nurse call system may fail to be triggered when movement is occurring outside of the motion sensors' range. For example, if movement is occurring on the other side of closed doors or on another level of the residence or building the motion detector may not be triggered. In this situation the central controller may not register an alarm signal.

Other Impairments

Similarly, Alarm Notification Appliances such as sirens, bells, horns, or strobes may not warn or waken a sleeping occupant if there is an intervening wall or door. It is less likely that the occupants will be alerted or awakened when notification appliances are located on a different level of the residence or premise.

Audible notification appliances may be interfered with by other noise sources such as stereos, radios, televisions, air conditioners, appliances, or passing traffic. Audible notification appliances, however loud, may not be heard by a hearing-impaired person.

Software

Most **MGC Systems** contain software. With respect to those products, MGC does not warrant that the operation of the software will be uninterrupted or error-free or that the software will meet any other standard of performance, or that the functions or performance of the software will meet the user's requirements. MGC shall not be liable for any delays, breakdowns, interruptions, loss, destruction, alteration or other problems in the use of a product arising out of, or caused by, the software.

Telephone Lines

Telephone service can cause system failure where telephone lines are relied upon by a **MGC System**. Alarms and information coming from an **MGC System** may not be transmitted if a phone line is out of service or busy for a certain period of time. Alarms and information may not be transmitted where telephone lines have been compromised by criminal tampering, local construction, storms or earthquakes.

Component Failure

Although every effort has been made to make this **MGC System** as reliable as possible, the system may fail to function as intended due to the failure of a component.

Security and Insurance

Regardless of its capabilities, no **MGC System** is a substitute for property or life insurance. Nor is the system a substitute for property owners, renters, or other occupants to act prudently to prevent or minimize the harmful effects of an emergency situation.

Moreover, building automation systems produced by MGC are not to be used as a fire, alarm, or life safety systems.

Warranty

Limited Warranty

Mircom Technologies Ltd., MGC Systems Corp. and MGC System International Ltd. together with their subsidiaries and affiliates (collectively, MGC) warrants the original purchaser that for a period of three years from the date of manufacture, proprietary manufactured product shall be free of defects in materials and workmanship, under normal use. During the warranty period, MGC shall, at its option, repair or replace any defective product upon return of the product to its factory, at no charge for labor and materials. **Non-proprietary, third party or OEM product shall be warranted in accordance with the warranty period of the manufacturer. Any replacement and/or repaired parts are warranted for the remainder of the original warranty or ninety (90) days, whichever is longer.** The original owner must promptly notify MGC in writing that there is defect in material or workmanship, such written notice to be received in all events prior to expiration of the warranty period.

International Warranty

The warranty for international customers is the same as for any customer within Canada and the United States, MGC shall not be responsible for any customs fees, taxes, or VAT that may be due.

Conditions to Void Warranty

This warranty applies only to defects in parts and workmanship relating to normal use. It does not cover:

- damage incurred in shipping or handling;
- damage caused by disaster such as fire, flood, wind, earthquake or lightning;
- damage due to causes beyond the control of MGC such as excessive voltage, mechanical shock or water damage;
- damage caused by unauthorized attachment, alterations, modifications or foreign objects;
- damage caused by peripherals (unless such peripherals were supplied by MGC);
- defects caused by failure to provide a suitable installation environment for the products;
- damage caused by use of the products for purposes other than those for which it was designed;
- damage from improper maintenance;
- damage arising out of any other abuse, mishandling or improper application of the products.

Warranty Procedure

To obtain service under this warranty, please return the item(s) in question to the point of purchase. All authorized distributors and dealers have a warranty program. Anyone returning goods to MGC must first obtain an authorization number. MGC will not accept any shipment whatsoever for which prior authorization has not been obtained. NOTE: Unless specific pre-authorization in writing is obtained from MGC management, no credits will be issued for custom fabricated products or parts or for complete fire alarm system. MGC will at its sole option, repair or replace parts under warranty. Advance replacements for such items must be purchased.

Note: MGC's liability for failure to repair the product under this warranty after a reasonable number of attempts will be limited to a replacement of the product, as the exclusive remedy for breach of warranty.

Disclaimer of Warranties

This warranty contains the entire warranty and shall be in lieu of any and all other warranties, whether expressed or implied (including all implied warranties of merchantability or fitness for a particular purpose) and of all other obligations or liabilities. MGC neither assumes nor authorizes any other person purporting to act on its behalf to modify or to change this warranty, or to assume for it any other warranty or liability concerning this product.

This disclaimer of warranties and limited warranty are governed by the laws of the province of Ontario, Canada.

Out of Warranty Repairs

MGC will at its option repair or replace out-of-warranty products which are returned to its factory according to the following conditions. Anyone returning goods to MGC must first obtain an authorization number. MGC will not accept any shipment whatsoever for which prior authorization has not been obtained.

Products which MGC determines to be repairable will be repaired and returned. A set fee which MGC has predetermined and which may be revised from time to time, will be charged for each unit repaired.

Products which MGC determines not to be repairable will be replaced by the nearest equivalent product available at that time. The current market price of the replacement product will be charged for each replacement unit.

The foregoing information is accurate as of the date of publishing and is subject to change or revision without prior notice at the sole discretion of the Company.

WARNING: MGC recommends that the entire system be completely tested on a regular basis. However, despite frequent testing, and due to, but not limited to, criminal tampering or electrical disruption, it is possible for this product to fail to perform as expected.

NOTE: UNDER NO CIRCUMSTANCES SHALL MGC BE LIABLE FOR ANY SPECIAL, INCIDENTAL, OR CONSEQUENTIAL DAMAGES BASED UPON BREACH OF WARRANTY, BREACH OF CONTRACT, NEGLIGENCE, STRICT LIABILITY, OR ANY OTHER LEGAL THEORY. SUCH DAMAGES INCLUDE, BUT ARE NOT LIMITED TO, LOSS OF PROFITS, LOSS OF THE PRODUCT OR ANY ASSOCIATED EQUIPMENT, COST OF CAPITAL, COST OF SUBSTITUTE OR REPLACEMENT EQUIPMENT, FACILITIES OR SERVICES, DOWN TIME, PURCHASER'S TIME, THE CLAIMS OF THIRD PARTIES, INCLUDING CUSTOMERS, AND INJURY TO PROPERTY.

MGC MAKES NO WARRANTY OF MERCHANTABILITY OR FITNESS FOR A PARTICULAR PURPOSE WITH RESPECT TO ITS GOODS DELIVERED, NOR IS THERE ANY OTHER WARRANTY, EXPRESSED OR IMPLIED, EXCEPT FOR THE WARRANTY CONTAINED HEREIN.



© Mircom 2017
Printed in Canada
Subject to change without prior notice

www.mircomgroup.com

TECHNICAL SUPPORT
North America
Tel: (888) Mircom5
(888) 647-2665
International
Tel: (905) 647-2665

U.S.A
4575 Witmer Industrial Estates
Niagara Falls, NY 14305
Tel: (888) 660-4655
(905) 660-4655
Fax: (905) 660-4113

CANADA - Main Office
25 Interchange Way
Vaughan, ON L4K 5W3
Tel: (888) 660-4655
(905) 660-4655
Fax: (905) 660-4113