

PRO-2000 LCD Expander Module

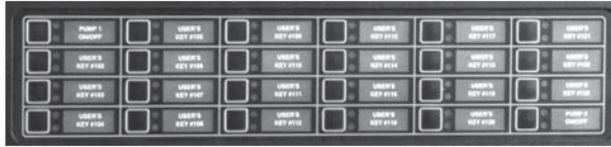

Features

- 24 programmable push buttons with associated LED pair per standard panel
- Switching power supply for increased power efficiency
- Removable connectors for easy servicing
- Serial interface with the LCD/Processing and Display Unit (LCD)

Description

The LCD Expander card allows for any PRO-2000 Series panel to control up to 24 programmable push buttons with their associated LED pairs. This increases the range of programmable push buttons that can be controlled from a standard X0, X2 or X6 panel.

A serial link ensures that information is relayed between the LCD/Processing and Display Unit (LCD) and the LCD Expander.

On the X2 type panels, the serial communication occurs between the Processing and Display Unit (LCD) and the LCD Expander.

On the X0 and X6 type panels, the serial communication occurs between the LCD and the LCD Expander card.

Each LCD Expander card has its own step down switching power supply that provides increased efficiency and reliability.

The LCD Expander card is fitted with removable connectors that facilitate field servicing.

Specifications

Electrical Specifications	
Input Voltage	20 to 28.5 VDC
Standby Input Current (all LED indicators OFF)	50 mA @ 24 VDC
Maximum Input Current (all LED indicators ON)	160 mA @ 24 VDC
LED Indicator	
Current per LED	2.2 mA @ 24 VDC
Serial Communication	
Input Serial Communication	As per RS-232 electrical standards
Output Serial Communication	As per RS-232 electrical standards
Physical Specifications	
Length	16.5" (419.1 mm)
Width	4.23" (107.4 mm) with base
Thickness	1" (25.4 mm)
Weight	42.33 oz (1200 g)



USCG
161.002/41/1
ABS
05-MO602743-X

CCG
Accepted

Block Diagram

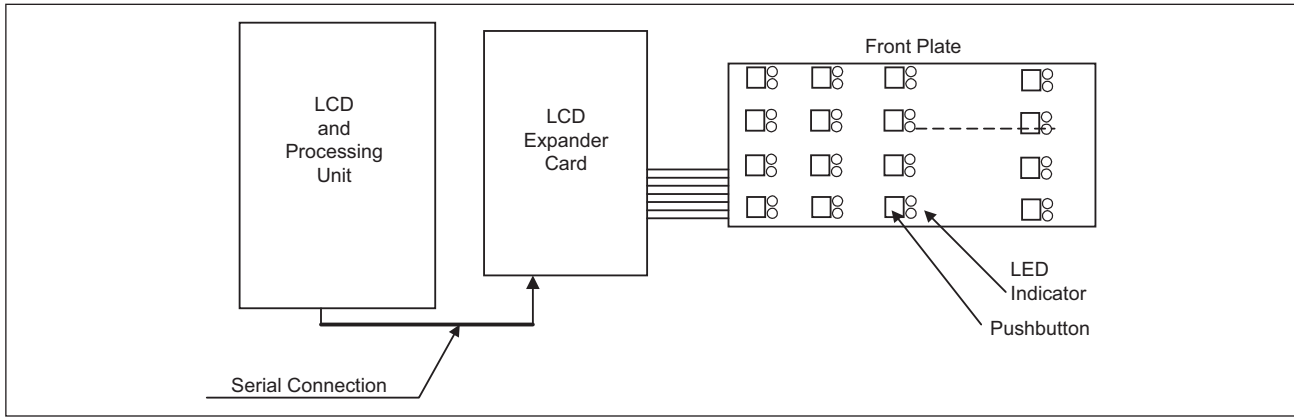

Typical Application

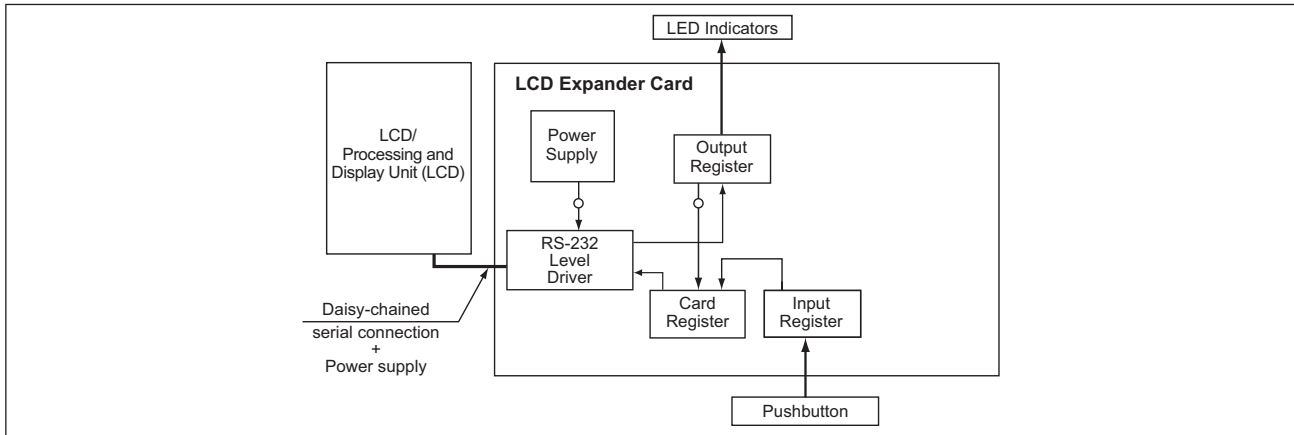

LCD Expander Card Connected to an X2 Type Panel

LCD Expander Card Connected to an X6 Type Panel

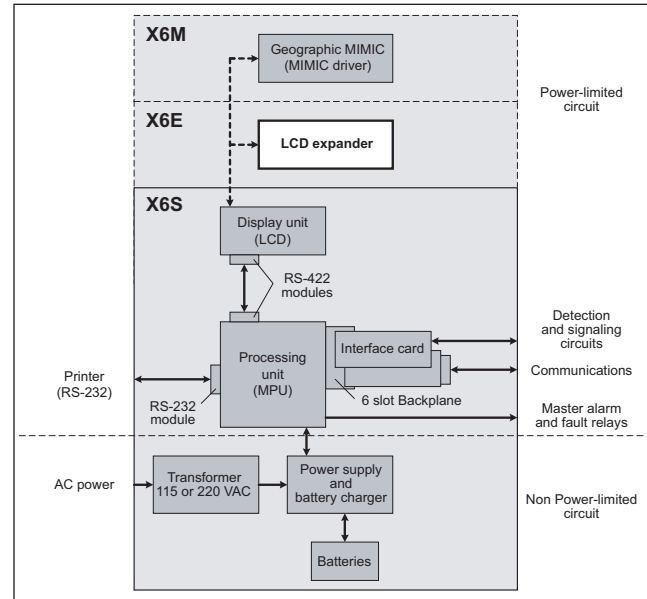
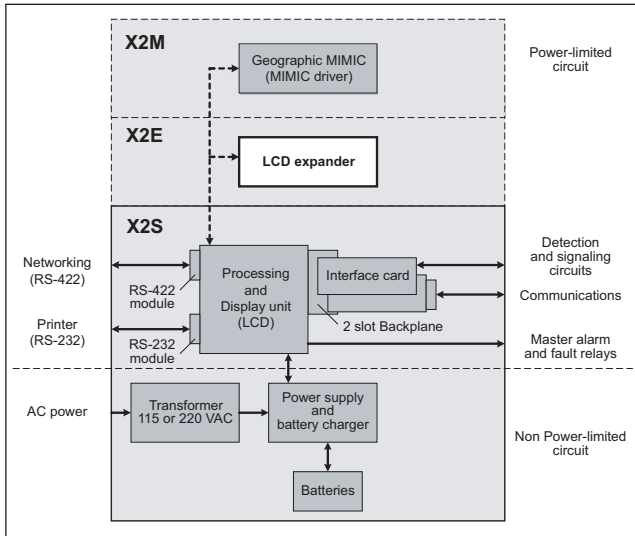

Ordering Information

Model Number	Description
PCA-14289-00	PRO-2000 LCD Expander Card, UL/ULC
PCA-14289-01	PRO-2000 LCD Expander Card, Marine
PAM-14402-00	Front Panel FS PRO-2000 LCD Expander, UL/ULC
PAM-14402-01	Front Panel FS PRO-2000 LCD Expander, Marine