

PRO-2000

12 Zone Supervised Relay Card

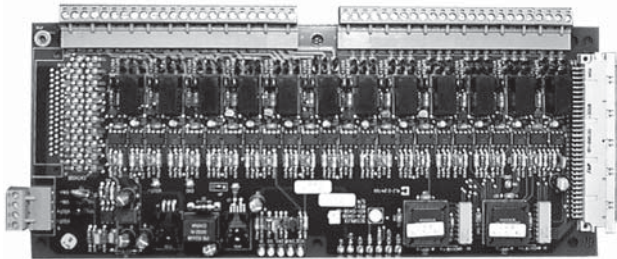

Features

- Up to 12 relay output circuits rated at 5A @ 30VDC/ 250VAC (resistive load)
- Suitable for interfacing with notification and activation devices
- Each output can be individually configured as supervised or unsupervised
- Each output can be individually configured as powered or unpowered
- Full transient protection
- Switching power supply for increased power efficiency
- Field electronics fully isolated from system electronics for increased electrical noise immunity
- Removable connectors for easy servicing

Description

The Supervised Relay Card enables a PRO-2000 Series panel to control output devices through 12 relay output circuits. Each output circuit can be configured to be supervised or not for cable fault detection. Each output can also be configured to be powered by the system supply or act as an unpowered contact.

The total current consumption for powered relays is limited to 900 mA. All outputs have full transient protection to prevent card damage in the event that a field power surge should occur.

The field electronics of the card is fully isolated from the system electronics, thus insuring an exceptional electrical noise immunity from the field connection.

The Supervised Relay Card is available in two versions. Both models are functionally equivalent with the difference residing in that one is equipped with a Combicon connector and the other with a DSUB-50 connector.

Specifications

Electrical Specifications	
Maximum Supplied Output Current	900 mA
Supervision Current	800 mA
Voltage Drive / Series Resistor	5V @ 330W
End-of-line Resistor Value	6.8K
Standby Current Consumption (excluding devices)	51 mA @ 24 VDC
Physical Specifications	
Length	11.9" (302.3 mm)
Width	4.85" (123.2 mm)
Thickness	1" (25.4 mm)



S7010



S7010

USCG
161.002/41/1

ABS

05-MO602743-X

CCG
Accepted

Block Diagram

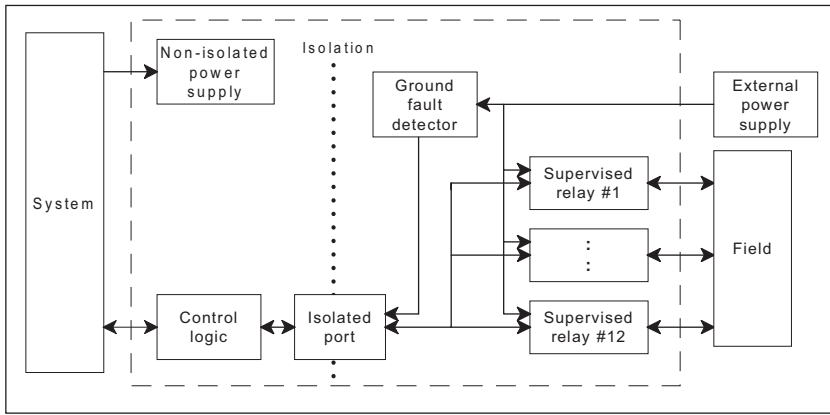

Card With Combicon Connectors

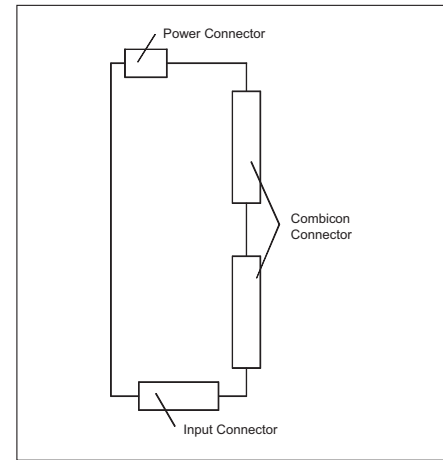

Typical Device Connecting Sketches

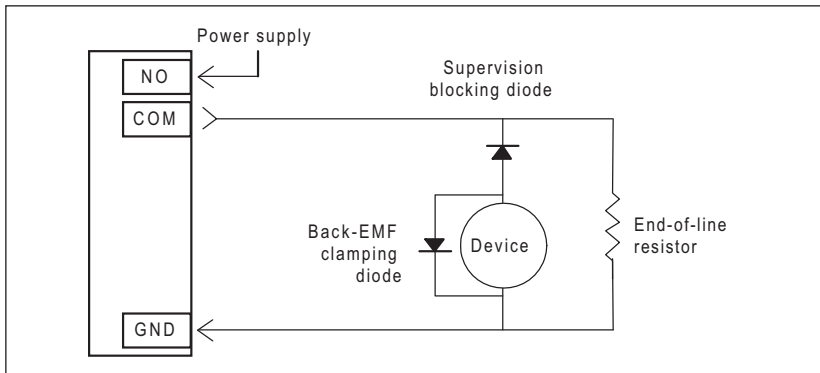

Card With DSUB-50 Connector

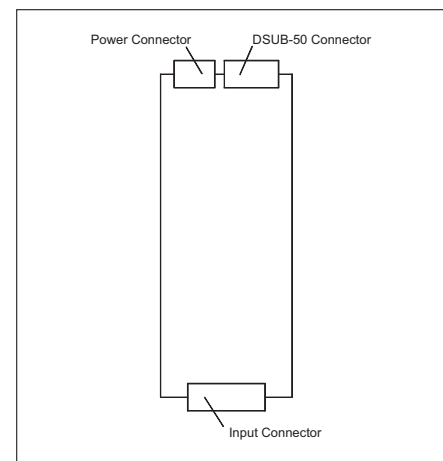

SO Card Connected to an X2 Type Panel

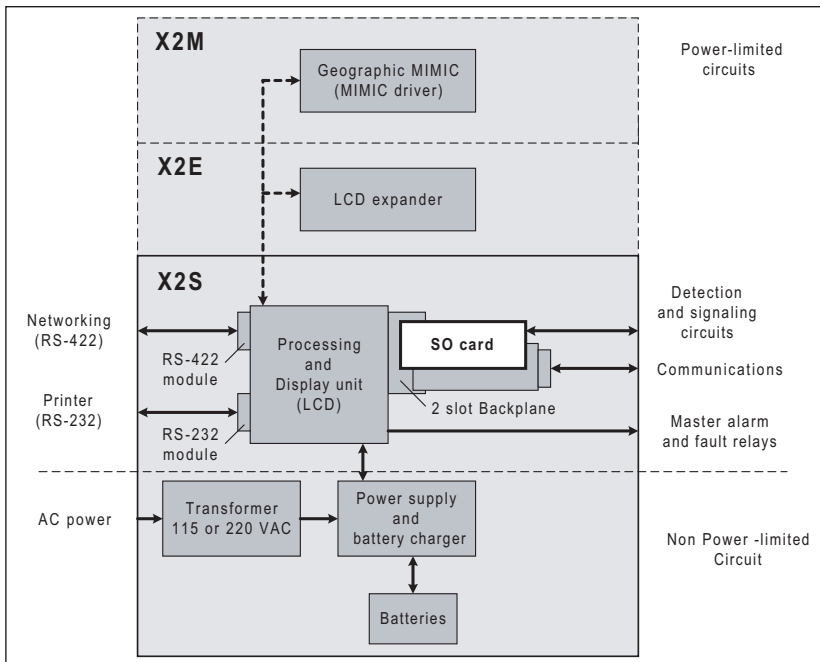

Ordering Information

Model Number	Description
PCA-13459-00	PRO-2000 12-Zone Supervised Relay Card with Combicon Connector, UL/ULC
PCA-13459-01	PRO-2000 12-Zone Supervised Relay Card with DSUB-50 Connector, UL/ULC
PCA-13459-02	PRO-2000 12-Zone Supervised Relay Card with Combicon Connector, Marine
PCA-13459-03	PRO-2000 12-Zone Supervised Relay Card with DSUB-50 Connector, Marine