

POLYCARBONATE EMERGENCY LIGHT SERIES MHP2-06030/2SQ



Features

- High impact, UV stabilized, thermoplastic construction
- Two fully adjustable square lamp heads
- Universal spider knockout pattern and keyhole mounting slots stamped into back of cabinet
- White colour is standard

Description

The MHP2-06030/2SQ series from Mircom offers a decorative, yet economical solution for your emergency lighting needs. The housing is made of thermoplastic and the lens are made of injection moulded, high impact polycarbonate, corrosion and flame resistant. The MHP2-06030/2SQ is a stand alone unit available in 6V and will provide 30 watts for 30 minutes of emergency lighting. The 2 square heads use 9w wedge base incandescent lamps which are fully adjustable and have an impact and heat resistant polystyrene lens. Polished specular reflectors insure maximum photometric distribution.

The MHP2-06030/2SQ unit is a completely self-contained emergency light which is made for use on 120 or 347 volt circuits. A 6V maintenance free, sealed lead acid battery is included with the MHP2-06030/2SQ which will provide up to 30 watts for 30 minutes of emergency lighting. The universal mounting plate is made to fit over a standard octagon box for simple, low cost installation. Once the plate is pre-mounted and all wiring connections terminated, the unit is snapped onto the plate, completing installation. White finish is standard.

The Mircom MHP2-06030/2SQ emergency lighting units come complete with high quality, pulse action chargers which are up to 70% more efficient than constant voltage chargers. The chargers are solid state and are complete with low voltage disconnect, brownout, and short circuit protections. An LED display indicates AC-ON, and all chargers are complete with a quick test, push-button switch for easy maintenance and testing. Recharge time is 24 hours.

Dimensions

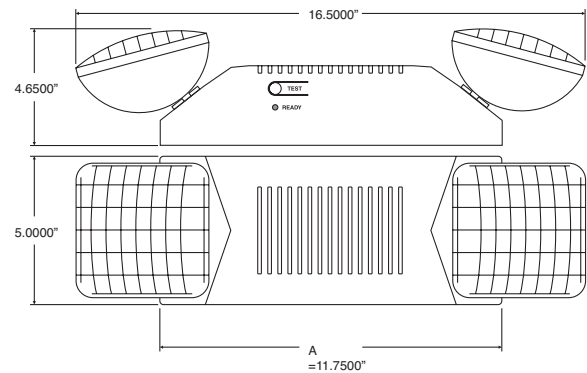

Approvals:
CSA Certified to C22.2 #141



CATALOG NUMBER **4109**

NOT TO BE USED FOR INSTALLATION PURPOSES.

Ordering Information

Model	Description
MHP2-06030/2SQ	Polycarbonate Emergency Light 6V, 30 watt 120/347VAC

NOT TO BE USED FOR INSTALLATION PURPOSES.



Canada

25 Interchange Way
Vaughan, Ontario L4K 5W3
Telephone: (905) 660-4655
Fax: (905) 660-4113

U.S.A.

4575 Witmer Industrial Estates
Niagara Falls, NY 14305
Toll Free: (888) 660-4655
Fax Toll Free: (888) 660-4113

Web page: <http://www.mircom.com> Email: mail@mircom.com

Distributed by:

ISO 9001:2008
REGISTERED



CAT. 4109
Rev. 0