



### Features

- Die cast, solid metal housing with die cast, twist lock lamp collar
- Complete adjustability - both tilt and swivel
- 5" diameter canopy standard
- Two canopy mounting holes designed to match standard electrical junction boxes
- White paint finish is standard
- MR16 lamp designed with low glare reflector and available in 6V, 12V or 24V

### Description

The Mircom MD Series are white die cast MR16 remote heads featuring a twist lock lens collar. The heads are fully adjustable in both tilt and swivel. Available with MR16 quartz halogen lamps up to 50W and 3.7W or 5.7W LED lamps. These remotes are designed for use with 6, 12 or 24V emergency lighting circuits. The 5" canopy mounts directly to a standard electrical box (not supplied). Standard finish is white.

### Dimensions

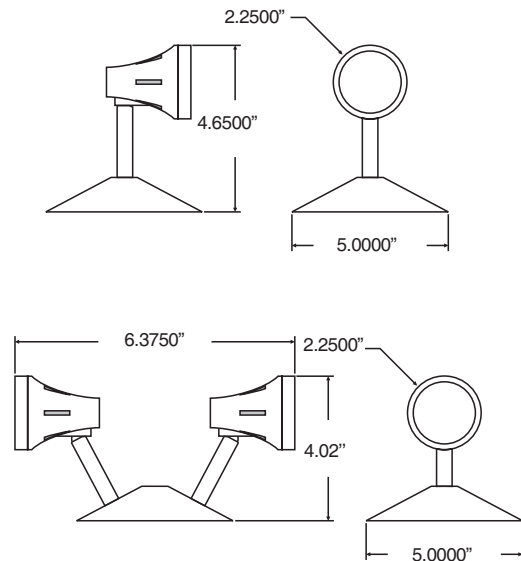

Approvals:  
CSA Certified to C22.2 #141



**CATALOG NUMBER 4111**

NOT TO BE USED FOR INSTALLATION PURPOSES.

Mircom reserves the right to make changes at any time without notice in prices, colours, materials, components, equipment, specifications and models and also to discontinue models.

## Ordering Guide

Series	Number of Heads	Voltage	Lamp Watts	Lamp Type
MD	1 - Single MR16 Head 2 - Double MR16 Head	06 - 6VDC	08, 10, 12, 20, 35, 50	Q -Quartz halogen
		12 - 12 VDC	08, 10, 12, 20, 35, 50	Q -Quartz halogen
			4W, 5.7W	L -LED
		24 - 24 VDC	08, 10, 12, 20, 35, 50	Q -Quartz halogen

NOT TO BE USED FOR INSTALLATION PURPOSES.



**Canada**  
25 Interchange Way  
Vaughan, Ontario L4K 5W3  
Telephone: (905) 660-4655  
Fax: (905) 660-4113

**U.S.A.**  
4575 Witmer Industrial Estates  
Niagara Falls, NY 14305  
Toll Free: (888) 660-4655  
Fax Toll Free: (888) 660-4113

Web page: <http://www.mircom.com> Email: [mail@mircom.com](mailto:mail@mircom.com)

Distributed by:

ISO 9001:2008  
REGISTERED



CAT. 4111  
Rev. 0