

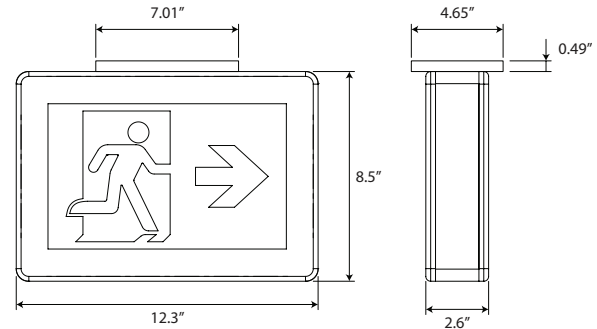

Dimensions

Description

By combining value with a modern design, the Mircom MRP series of high impact thermoplastic commercial running man signs provide ideal exit signage solutions. Supplied standard with long-life, high brightness LEDs, the MRP series are also energy efficient with energy consumption as low as just 1.8W. AC Installation is quick and easy since each sign is designed and supplied with quick-snap faceplates, backplate and universal canopy. All backplates are stamped with a universal mounting pattern for even greater installation ease and flexibility.

Features

The Mircom MRP running man series are designed utilizing an all thermoplastic construction. The plastic is UV stabilized, lightweight, impact and scratch resistant. The MRP sign is white in colour.

Circuitry

All MRP signs are supplied with 120/347VAC dual input voltage, available in AC only, AC/DC and self-powered models. AC/DC models feature universal emergency backup DC voltages: 6, 12 or 24VDC, each field selectable. Emergency power wattages are of 0.9 watts @ 6VDC, 12VDC and 24VDC. Self-powered models utilize an internal, solid state charger and come complete with high performance Ni-Cad batteries, supplying 90 minutes of emergency power. Up to 120 minutes extended duration batteries are optional.



Comes standard with three pictogram legends for direction selection.

Approvals:
CSA Certified to C22.2 #141



CATALOG NUMBER 4120

NOT TO BE USED FOR INSTALLATION PURPOSES.

Mircom reserves the right to make changes at any time without notice in prices, colours, materials, components, equipment, specifications and models and also to discontinue models.

Ordering Guide

Series	Number of Faces	Colour	DC Output
MRP	0 - Universal faces	WH - White	NDC - AC Only UDC - Universal DC backup voltage from 6 to 24VDC IB - Self-powered for 90 minutes IB1 - Self-powered for 120 minutes

NOT TO BE USED FOR INSTALLATION PURPOSES.



Canada
25 Interchange Way
Vaughan, Ontario L4K 5W3
Telephone: (905) 660-4655
Fax: (905) 660-4113

U.S.A.
4575 Witmer Industrial Estates
Niagara Falls, NY 14305
Toll Free: (888) 660-4655
Fax Toll Free: (888) 660-4113

Web page: <http://www.mircom.com> Email: mail@mircom.com

Distributed by:

ISO 9001:2008
REGISTERED



CAT. 4120
Rev. 0