



Features

Input Power on AC (when charging)	6W
Output Power on Battery	1.5W
Input Voltage	120/347 VAC
Frequency	60 Hz
LED Type	SMD LED
Battery Type	Ni-Cd
Working Time	120 Minutes
Charging Time	15-24 Hours

Description

- Injection-molded thermoplastic ABS housing
- UL-94V-0 flame rating, fire-retardant
- 2-sided sign
- Wall, side and ceiling mountable
- Input Power on AC is 1W when fully charged
- Input Voltage: 120/347 VAC, 60Hz
- Super bright SMD LED strip
- Nickel Cadmium Battery 3.6V 1000mAh
- Test switch and charge indicator light
- Overcharge & Over-discharge protection
- Backup time: ≥120 minutes
- Conversion time: <0.2 second
- IP Class: IP20
- Insulation: II
- Operating Temperature: 0 °C ~ 40 °C / 32 °F ~104 °F

Technical Drawing

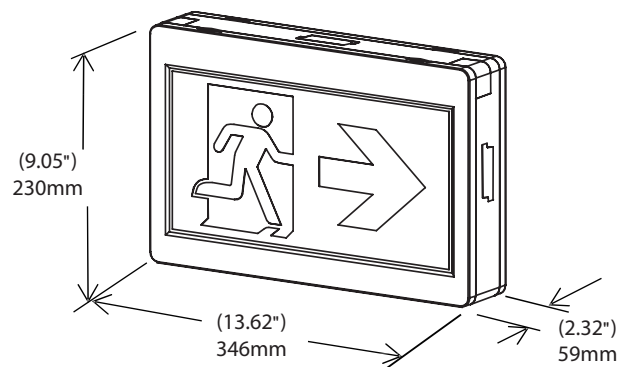

Included Pictograms



With Arrow 2 pcs



Without Arrow 1 pc



Ordering Information

Model	Description
ELRM-100	LED Running Man Sign

Canada

25 Interchange Way Vaughan, ON L4K 5W3
 Telephone: (905) 660-4655 | Fax: (905) 660-4113

U.S.A.

4575 Witmer Industrial Estates Niagara Falls, NY 14305
 Toll Free: (888) 660-4655 | Fax Toll Free: (888) 660-4113

www.mircom.com



THIS INFORMATION IS FOR MARKETING PURPOSES ONLY AND NOT INTENDED TO DESCRIBE THE PRODUCTS TECHNICALLY.

For complete and accurate technical information relating to performance, installation, testing and certification, refer to technical literature. This document contains intellectual property of Mircom. The information is subject to change by Mircom without notice. Mircom does not represent or warrant correctness or completeness. All rights reserved. All other trademarks and registered trademarks are properties of their respective owners.