



**Features**

Power (W)	2 x 3W
Lamp Type	SMD LED
Input Voltage	3.6V - 24VDC
IP Class	IP65
Lumens	2x 200

**Description**

- Suitable for use in wet locations
- Manufactured with extra seals and gaskets
- High impact thermoplastic housing
- Clear polycarbonate lens for bright illumination
- UL 924 Compliant
- Wall and ceiling mounting
- Universal voltage LED remote compatible with any emergency lighting system (3.6-24 VDC)
- Reverse polarity protection
- Super bright 2x3W SMD LED
- IP Class: IP65
- Operating temperature: 0 °C ~ 40 °C / 32 °F ~ 104 °F

**Technical Drawing**

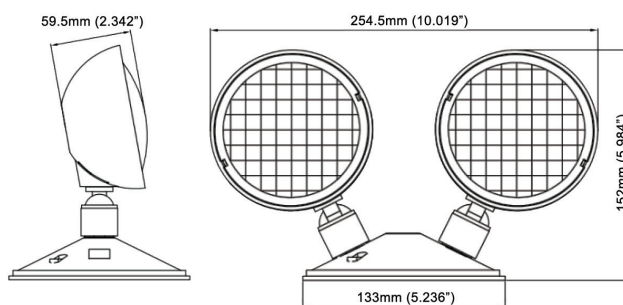

**Ordering Information**

Model	Description
EL-7030BWP	Weather Protected Double LED Remote Head (Universal Voltage), 20 per case



**Canada**  
 25 Interchange Way Vaughan, ON L4K 5W3  
 Telephone: (905) 660-4655 | Fax: (905) 660-4113

**U.S.A.**  
 4575 Witmer Industrial Estates Niagara Falls, NY 14305  
 Toll Free: (888) 660-4655 | Fax Toll Free: (888) 660-4113

www.mircom.com

This document is provided by Mircom Technologies Ltd., MGC Systems Corp., or their affiliates, subsidiaries and brands, for convenience or marketing only and does not describe products or services technically. For technical information refer to technical manuals. We do not make representations or warranties regarding this information, including as to completeness or accuracy. We may change these contents at any time and reserve all rights in the contents, including copyrights, trademarks and other intellectual property. All other trademarks and registered trademarks are properties of their respective owners.

**CATALOG NUMBER 4152**

Rev. 2