



Features

Power on AC	2.5W
Lamp Type	2x1.2W LED
Input Voltage	120-347 VAC
Frequency	50/60Hz
Battery Type	Ni-cd
LED Type	SMD LED
Working Time	180 Minutes
Charging Time	24 Hours

Description

- Injection-molded thermoplastic ABS housing
- UL-94V-0 flame rating, fire-retardant
- Wall and ceiling mountable
- Input Voltage: 120-347 VAC 50/60Hz
- 2x1.2W Lamps for Emergency Mode
- Super bright SMD LED - 100 Lumens per lamp head
- Nickel Cadmium Battery 3.6V 1800mAh
- Test switch and charge indicator light
- Overcharge & Over-discharge protection
- Backup time: 180 minutes
- Conversion time: <0.2 second
- IP Class: IP20
- Insulation: II
- Operating Temperature: 0 °C ~ 40 °C / 32 °F ~104 °F

Technical Drawing

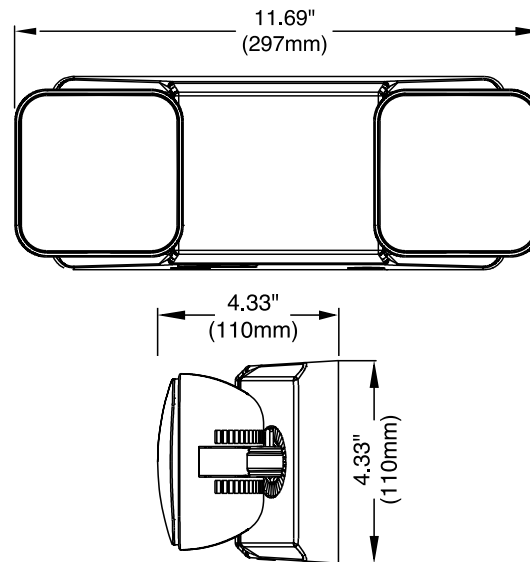

Ordering Information

Model	Description
EL-7006	Emergency Light (Twin Square)

Canada
 25 Interchange Way Vaughan, ON L4K 5W3
 Telephone: (905) 660-4655 | Fax: (905) 660-4113

U.S.A.
 4575 Witmer Industrial Estates Niagara Falls, NY 14305
 Toll Free: (888) 660-4655 | Fax Toll Free: (888) 660-4113

www.mircom.com



THIS INFORMATION IS FOR MARKETING PURPOSES ONLY AND NOT INTENDED TO DESCRIBE THE PRODUCTS TECHNICALLY.

For complete and accurate technical information relating to performance, installation, testing and certification, refer to technical literature. This document contains intellectual property of Mircom. The information is subject to change by Mircom without notice. Mircom does not represent or warrant correctness or completeness. All rights reserved. All other trademarks and registered trademarks are properties of their respective owners.