



### Description

The MIR-2400A photoelectric type smoke detector is specially designed to meet the stringent performance requirements of industrial and municipal fire detection/ alarm systems. The design of the detector emphasizes ease of installation and field maintenance.

All MIR-2400A photoelectric smoke detectors contain a unique optical sensing chamber designed to sense the presence of smoke particles produced by a wide range of combustion sources and meet the performance criteria designated by ULC. A new custom integrated circuit incorporates signal processing to reduce false alarms and sample/hold circuitry to provide easy field metering of sensitivity.

The MIR-2400A photoelectric detector is designed to be compatible with all Mircom Fire Alarm Control Panels. See Installation manual for panel to determine maximum number of detectors per zone. Easy to install and maintain, this detector is designed for direct surface mounting (mounting bracket included), or mounting to a 4" octagon or smaller box. Easy-to-wire screw terminals allow fast and simple field wiring of in, out and remote annunciator connections.

### Features

- Unique optical sensing chamber
- Superior signal-to-noise ratio
- Built-in signal processing
- 3.0% nominal sensitivity
- Removable cover for field cleaning
- Visible LED "blinks" in standby
- Sealed against dirt, insects and back pressure
- 3 year warranty
- 8.5-35 VDC operating range
- Field metering of detector sensitivity
- Built-in test capability
- Low standby current
- Twist-on mounting bracket with tamper option
- Designed for direct surface or electrical box mounting
- Insect-resistant screening
- SEMS screws for easy wiring

### Application

Use for protection of life and property. Photoelectric detectors are recommended in areas where slow smoldering fires are likely to ignite. In areas where small combustion particles are usually present from fork-lift trucks, cooking stoves, etc., they are less likely than ionization detectors to produce false alarms.

The MIR-2400A has been designed to seal the sensing chamber from back pressure air flow, dust, dirt, and insects. The back of the detector is sealed and the chamber is protected by a fine mesh (.20"/.508 mm) screen. If cleaning is required, it is easy to remove the cover (with a tool) and obtain access to the screen and chamber to perform a thorough cleaning.

### Architect/Engineer Specifications

The detector shall be of the photoelectric type. The detector shall have a nominal sensitivity as measured in a ULC smoke box, and a signal to noise ratio of 2.0 nominal. It shall be possible to perform calibrated sensitivity and functional operating tests on the detector without generating an aerosol. Functional testing will exercise the sensing chamber, and critical operating circuits.



## Architects/Engineer Specifications

The detector shall incorporate a solid stage voltage regulator which can maintain detection sensitivity over an input voltage range of 8.5-35.0 VDC. Standby current shall be no more than 120 microamperes. The detector shall be protected against power surges and noise immunity circuitry shall protect the detector so that it can be wired without shielded circuit conductors or conduit, where codes allow. The detector will operate without regard for input voltage polarity.

The detector shall have a mounting bracket with a built-in tamper resistant feature. The bracket shall allow for direct surface mounting or mounting to a 3 1/2" or 4" octagon box.

A visual indication of an alarm shall be provided by a latching light emitting diode (LED) on the detector which may be seen at ground level. It shall flash every ten seconds indicating that power is applied to the detector, and that the sensitivity of the detector is greater than 6% grey smoke per foot. The visible alarm signal shall be capable of remote LED annunciation.

A special test module shall be available to precisely verify the calibration and sensitivity of the detector to within its labelled operating range.

Metering points for the test shall be accessible on the exterior of the detector. Sensitivity shall be verifiable without affecting the normal operation of the detector, and without causing alarm actuation.

The detector shall be listed for normal operation in sustained velocities of up to 3000 feet per minute. The detector shall have a .20" opening insect screen, and shall be easily disassembled for field cleaning and inspection. Wire connections are made by clamping plate and screw. The detector shall be supplied by Mircom.

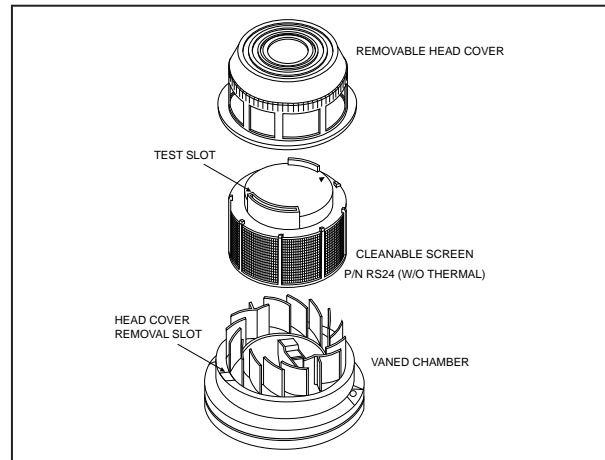

## General Specifications

Control Panel Applications .....	2-wire
Built-in Thermal.....	NO
Visual LED Local Alarm.....	YES
Remote LED Annunciator Capacity.....	YES
Operating Voltage Range.....	8.6-35VDC
Current Limits	
a) Standby (max.).....	120mA
b) Alarm Current (typical).....	See NOTE 1
c) Alarm Current (maximum).....	See NOTE 1
Reversed Voltage (non-alarm)	
Alarm Signal.....	Shunt on power leads

### Notes

- 1) Control panels must limit current to 100 mA or less
- 2) Max. air velocity for photoelectric sensor operation is 3000 feet per minute
- 3) Relative humidity range: 10 to 93% (non-condensing)

## Ordering Information

Model	Description
MIR-2400A	Photoelectric detector, 2-wire, surface mount
MOD400	Field test module for all of the 2400 series smoke detectors
RA-400Z	Remote annunciator (LED)
DUST-45	Protective Dust Cover

NOT TO BE USED FOR INSTALLATION PURPOSES.



### Canada

25 Interchange Way  
Vaughan, Ontario L4K 5W3  
Telephone: (905) 660-4655  
Fax: (905) 660-4113

### U.S.A.

4575 Witmer Industrial Estates  
Niagara Falls, NY 14305  
Toll Free: (888) 660-4655  
Fax Toll Free: (888) 660-4113

Web page: <http://www.mircom.com> Email: [mail@mircom.com](mailto:mail@mircom.com)

Distributed by:

ISO 9001:2008  
REGISTERED



CAT. 5126  
Rev. 5