



Description

Mircom's BB-400 Series back boxes are designed for indoor surface mount applications. Available in red and white models, the BB-400 Series back boxes are compatible with Mircom's 400 Series LED Notification Appliances. The durable plastic back boxes come with conduit entries on all sides as well as a knock-out at the back.

Features

- Designed for indoor surface mount applications
- Compatible with Mircom 400 Series LED Notification Appliances
- Red and white models

Dimensions

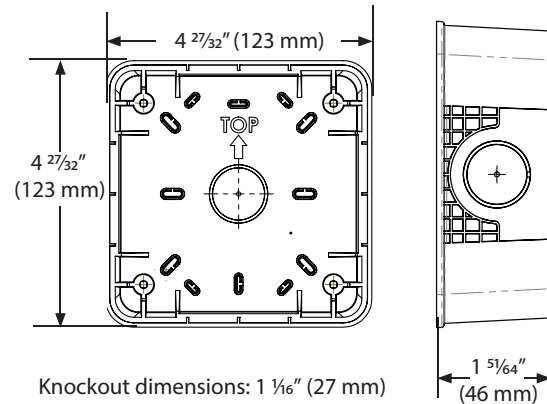

Mounting

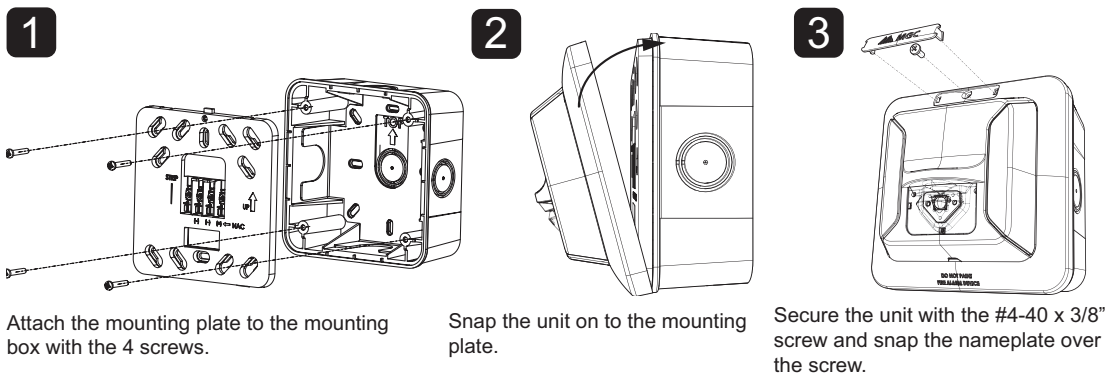

Ordering Information

Model	Description
BB-400R	Surface Mount Back Box, Red
BB-400W	Surface Mount Back Box, White



Canada
 25 Interchange Way Vaughan, ON L4K 5W3
 Telephone: (905) 660-4655 | Fax: (905) 660-4113

U.S.A.
 4575 Witmer Industrial Estates Niagara Falls, NY 14305
 Toll Free: (888) 660-4655 | Fax Toll Free: (888) 660-4113

www.mircom.com



THIS INFORMATION IS FOR MARKETING PURPOSES ONLY AND NOT INTENDED TO DESCRIBE THE PRODUCTS TECHNICALLY.

For complete and accurate technical information relating to performance, installation, testing and certification, refer to technical literature. This document contains intellectual property of Mircom. The information is subject to change by Mircom without notice. Mircom does not represent or warrant correctness or completeness. All rights reserved. All other trademarks and registered trademarks are properties of their respective owners.

CATALOG NUMBER 5365

Rev. 0