



BB-1002WPRA / BB-1002WPA

Description

The BB-1002WP(R)A is a complete enclosure that comes with either a RED or WHITE door, a black back-box, two keys and a durable lock at the top of the door.

The door comes hinged to the bottom side of the box for added weather protection.

The box is capable of handling one RAM-1032TZDS-CC Main Annunciator Chassis which provides up to 32 points of annunciation and one RAX-1048TZDS-CC Adder Annunciator, which provides up to 48 points of annunciation. RAM-1032TZDS-CC and RAX-1048TZDS-CC are ordered separately to match the UL, ULC installation requirements

Note: there is no need for thermostat or heater.

RAM-1032TZDS-CC and RAX-1048TZDS-CC must be ordered separately to match UL, ULC installation requirements.

Features

- UL, ULC Weather Protected, for indoor and outdoor applications
- White or red semi-gloss finishing, and black back box
- Lexan sealed window, to protect against the challenges of an outdoor application
- Easy to install with 2 knockouts for wiring, with 7/8" diameter
- For surface mount application
- Easy to install and maintain: Heater or Thermostat is not needed

Specifications

Dimensions	Height: 17-15/16" (456mm) Width: 12-15/16" (329mm) Depth: 3-1/2" (89mm)
Rated for Outdoor Environment	+50°C to -40°C (+122°F to -40°F)
Wet Location	95% R.H. @60°C

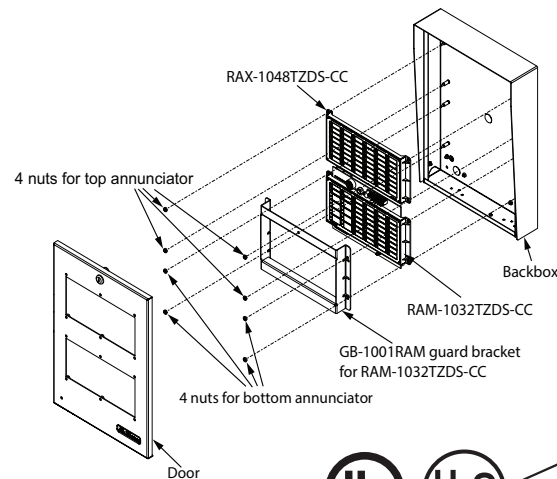

Ordering Information

Model	Description
BB-1002WPA	Weather Protected Enclosure – Houses 2 modules - WHITE
BB-1002WPRA	Weather Protected Enclosure – Houses 2 modules - RED
RAM-1032-TZDS-CC	Conformal Coated 32 Zone Remote LED Annunciator with 32 Bi-Coloured Trouble LEDs
RAX-1048TZDS-CC	Conformal Coated Adder 48 Zone Annunciator with 48 Bi-Coloured Trouble LEDs

Canada
25 Interchange Way Vaughan, ON L4K 5W3
Telephone: (905) 660-4655 | Fax: (905) 660-4113

U.S.A.
4575 Witmer Industrial Estates Niagara Falls, NY 14305
Toll Free: (888) 660-4655 | Fax Toll Free: (888) 660-4113

www.mircom.com



THIS INFORMATION IS FOR MARKETING PURPOSES ONLY AND NOT INTENDED TO DESCRIBE THE PRODUCTS TECHNICALLY.

For complete and accurate technical information relating to performance, installation, testing and certification, refer to technical literature. This document contains intellectual property of Mircom. The information is subject to change by Mircom without notice. Mircom does not represent or warrant correctness or completeness.