

INTELLIGENT FIRE ALARM AND AUDIO NETWORK SYSTEM



BBX-FXMNSR

BBX-5014R

Description

Mircom's Flex-Net Series is a powerful intelligent networkable fire alarm solution designed with many levels of flexibility to meet virtually any application of detection, control, notification and emergency communications. Features such as fire detection & alarm, audio/voice evacuation, BACnet, Boolean logic, networking and graphical work stations allow this modular solution to accommodate the simplest systems up to the most complex solutions.

With the addition of the Advance Protocol (AP), Fire/CO detection and 520 Hz support on both the addressable loop and through the audio/voice evacuation, Mircom's Flex-Net is poised to take you even farther into the future with expanded capabilities.

Designed for peer-to-peer network communications, the Flex-Net Series allows for a maximum of 63 nodes, while providing reliability, flexibility and expandability.

Each base panel consists of one intelligent signaling line circuit (SLC) capable of supporting 159 analog Sensors and 159 addressable modules. In addition the base panel includes Four Style Z/Y (Class A/B) Notification Appliance Circuits and an easy to read and use, large 4 x 20 back-lit alphanumeric LCD display.

The audio control provides a multi-channel distributed audio system that allows for efficient emergency paging, evacuation signaling (compatible with 520Hz low frequency signal) and fire fighters' telephone communication. Each audio card cage supports a maximum of 4 QAA style amplifiers for a maximum of 180 watts per cabinet.

The network configuration allows the Flex-Net Series control panel to be connected to a Mircom network to provide additional input circuits, visual zones, programmable notification appliance circuits, and relays. The network interface module allows the panels to communicate on a peer-to-peer network via a Proprietary Arcnet Network Communications protocol.

Features

Fire Alarm Control

- 1 SLC loop expandable up to 29
- Each SLC is capable of supporting 159 Analog Sensors and 159 Addressable Modules which can be wired in Style 6 or 7 (Class A) or Style 4 (Class B)
- Four Style Z/Y (Class A/B) Notification Appliance Circuits rated at 1.7 Amps each
- Supports both 80 character and 960 character back-lit LCD displays with user friendly menu
- English, French, Arabic* and Hebrew* language support (*supported by RAXN-LCDG Annunciator in place of main display)
- Correlatable Switch Inputs which allows for multi-functional outputs
- Four Alarm Queues with selector switches and LEDs for Alarm, Supervisory, Monitor and Trouble
- RS-232 output for remote system printer or CRT
- Two Event History Logs comprised of a 6000 Alarm History Log and a 6000 Event Log for all events
- Built-in BACnet support
- System can be configured without taking the panel offline
- Supports three configuration files (current, previous and next configuration) with "hot swap" support
- Real time 3D graphical monitoring and control using Mircom's Open Graphic Navigator™
- Supports Boolean logic functions
- Built-in Ethernet port
- Remote diagnostics via a built-in web server
- UL listed for Smoke Control (UUKL)

Audio Control

- Multi-channel operation
- Distributed audio
- Compatible with 520Hz low frequency signal by Mircom
- 5 hard wire fire fighter telephone channels that can be expanded with intelligent fire phone modules
- 25 or 70 volt system
- Multiple amplifier sizes
- Max. of 180 watts per Integrated Fire & Audio panel
- Expansion to three 360 watts expansion cabinets for a total of 1260 watts of audio power per node

Network Features

- Up to 63 nodes
- Peer-to-peer network communications
- Fully integrated digital network audio and control over a single pair of copper wire or fiber optic cable
- Supports over 9,000 points per node
- Supports over 580,000 points on a single network
- Remote diagnostics via built in web server and standard Ethernet port in every node
- Style 4 (Class B) or Style 6 or 7 (Class A) wiring configuration
- Proprietary Arcnet Network Communications protocol



S7010



S7010



7165-1477:111

NYC
Fire Dept
COA# 6064



APPROVED

CATALOG NUMBER

5940

FleX-Net Integrated Fire and Audio Control Panels



FX-2009-12NDS Large Network Main Control Unit

The FX-2009-12NDS Large Network Main Control Unit consists of a base fire alarm panel with one isolated intelligent Signaling Line Circuit (SLC) Style 4, 6 or 7, Four Style Z/Y (Class A/B) NAC circuits, a 4 line by 20 character LCD display and a 12 Amp power supply. The FX-2009-12NDS has space to mount the FNC-2000 Fire Network Controller Module, ANC-5000 Audio Network Controller Module, TNC-5000 Telephone Network Controller Module and provision to mount up to 4 adder modules. The FX-2009-12NDS mounts in a BB-5000 Series enclosure and supports Audio Lobby Control modules, Fire Fighter's Lobby Control modules and FX-2000 Internal Annunciator / Programmable modules.



ECX-0012 Expander Chassis

The ECX-0012 Expander Chassis for the FX-2009-12NDS supports up to 12 adder modules and has space for 2 internal annunciator modules. The ECX-0012 mounts in the BB-5000 series enclosures.



BB-5008/BB-5014 Enclosures

The BB-5008 and BB-5014 enclosures support the FX-2009-12NDS and provide space for internal lobby control modules. The cabinets hold up to 24 AH batteries. The door and chassis hardware are ordered separately.

BB-5008 Dimensions: 36"H x 30"W x 7"D

BB-5014 Dimensions: 60"H x 30"W x 7"D



FX-2000MNS Main Network Board

The FX-2000MNS main network board includes one intelligent Signaling Line Circuit (SLC) and Four Style Z/Y (Class A/B) NAC circuits. The FX-2000MNS has provisions to mount up to 9 internal adder modules and mounts in the BBX-FXMNS enclosure.



QMB-5000N Integrated Audio Network Chassis

The QMB-5000N includes the audio and telephone control which consists of an audio card cage designed for mounting the ANC-5000 Audio Network Controller Module, TNC-5000 Telephone Network Controller Module and up to four QAA style audio amplifiers. The QMB-5000N connects to the FX-2000MNS main board and mounts in the BBX-FXMNS enclosures. The QMB-5000N supports audio expansion with connection to up to three QBB-5001 Audio Cabinets. Each QBB-5001 can support a maximum 360 watts.

Electrical Specifications

Fire Alarm Primary Input Power	120V 60Hz / 240V, 50Hz 4 Amps / 2 Amp (primary)
Power Supply Ratings	12 Amps. max. (secondary)
For NAC Circuits	24VDC unfiltered, 10 Amps. max.
Battery Type	24VDC, Gel-Cell/Sealed Lead-Acid
Battery Charging Capability	17-65 AH batteries
Audio Primary Input Power (QPS-5000N)	120 VAC, 60Hz / 240 VAC, 50Hz 12 Amps

Flex-Net Integrated Fire and Audio Control Panels



DSPL-420 Main Display Module

The DSPL-420 Main Display Module provides a 4 line by 20 character backlit LCD display, Common Control buttons and Four Status Queues with selector switches and LEDs for Alarm, Supervisory, Trouble and Monitor. The DSPL-420 occupies one display position in the BBX-FXMNS enclosure.



DSPL-420-16TZDS Main Display Module

The DSPL-420-16TZDS Main Display Module provides a 4 line by 20 character backlit LCD display, Common Control buttons and Four Status Queues with selector switches and LEDs for Alarm, Supervisory, Trouble and Monitoring with an additional 16 LED points of annunciation. The DSPL-420-16TZDS occupies one display position in the BBX-FXMNS enclosure.



DSPL-2440 Graphical Main Display Module

The DSPL-2440 Graphical Main Display Module provides a 24 line x 40 character backlit LCD display, Common Controls buttons and Four Status Queues with selector switches and LEDs for Alarm, Supervisory, Trouble and Monitor. The DSPL-2440 occupies one display position in the BBX-FXMNS enclosure.



QMP-5101NV Network Master Paging Control Module

The QMP-5101NV Network Master Paging Control Module includes the paging microphone and common control indicators. The QMP-5101NV allows for all call paging or selective paging with the QAZT-5302DS Zoned Paging and Telephone Selector Modules. The QMP-5101NV is a vertical mount unit that mounts in the BBX-FXMNS enclosure.



QMT-5302NV Network Master Fire fighters' Telephone Control Module

The QMT-5302NV includes the Master Telephone Handset and common control indicators. The QMT-5302NV supports the QAZT-5302DS Paging and Telephone selector modules. The QMT-5302NV is a vertical mount unit that mounts in the BBX-FXMNS enclosure.



BBX-FXMNS Enclosure

The BBX-FXMNS enclosure supports the FX-2000MNS Network main board, a DSPL-420, DSPL-420-16TZDS or DSPL-2440 Main LCD display, a QMB-5000N audio card cage, a QMP-5101NV Master Paging Microphone and a QMT-5302NV Master Telephone Handset. In addition the enclosure provides space for additional external modules and internal lobby control modules. The BBX-FXMNS holds up to 40 AH batteries and is available with a white (BBX-FXMNS) or red (BBX-FXMNSR) door.

BBX-FXMNS Dimensions: 61.5"H x 20"W x 9"D

Power Supply Expansion



INX-10AC Internal Booster Power Supply Module

Mircom's INX-10AC is an Intelligent Booster Power Supply that extends the power capabilities of existing notification appliance circuits as well as provide power for other ancillary devices. The INX-10AC has 10 amps of power and mounts inside the BB-5014 enclosure.

Fire Network Controller Modules



FNC-2000 Fire Network Controller Module

The FNC-2000 provides network capability to the FX-2009-12NDS. One Fire Network Controller Module is required per network node panel. In addition the FNC-2000 provides an interface for adding an optional FOM-2000-SP Fiber Optic Network Adder Module. The FNC-2000 mounts in the FX-2009-12NDS.



FOM-2000-SP Fiber Optic Network Adder Module

The FOM-2000-SP Fiber Optic Network Adder Module allows for the use of fiber optic cabling on the FX-2009-12NDS. It seamlessly connects to the interface on the FNC-2000 Fire Alarm Network Controller Module.

Adder Loop Controller Modules



ALCN-792MISO Isolated Quad Loop Controller Module

The ALCN-792MISO Isolated Quad Loop Controller Module provides two Signaling Line Circuits (SLC) to the FleX-Net system consisting of 159 Analog Sensors and 159 Addressable Modules per loop. The ALCN-792MISO can be expanded with the use of the ALCN-792D Daughter Board Module. The ALCN-792MISO occupies one module slot.



ALCN-792D Daughter board for Isolated Quad Loop Controller Module

The ALCN-792D Daughter Board provides an additional two SLC loops when connected to the ALCN-792MISO Isolated Quad Loop Controller Module. The daughter board mounts on top of the ALCN-792MISO.

Adder Hardware Modules



DM-1008A Eight Initiating Circuit Module

The DM-1008A provides 8 Style B (Class B) or 4 Style D (Class A) Initiating Circuits configurable for Alarm, Supervisory or Trouble zones. The DM-1008A occupies one module slot.



SGM-1004S Four Notification Appliance Circuit Output Module with Built-in Synchronization

The SGM-1004S provides up to four indicating circuits each rated at regulated 24 VDC/FWR 1.7 Amps (5 Amps maximum per SGM-1004S) to signal devices such as strobes, bells, horns, etc., and for special applications it is rated at 33 VDC/FWR 2.1 Amps (5 Amps maximum per SGM-1004S). Each of the indicating circuits can be configured as non-silenceable (steady) or silenceable. SGM-1004S enables the compatible fire alarm control panels to have synchronized NAC circuits.

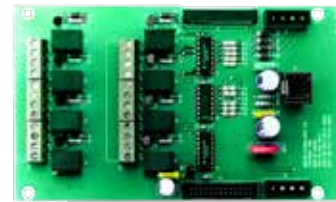

RM-1008A Eight Relay Circuit Module

The RM-1008A provides the system with eight individual configurable relays per module. Each relay provides one Form C contact rated at 28 VDC @1 Amp (resistive load) as well as a Green LED to indicate that the relay is active. The RM-1008A occupies one module slot.

Adder Auxiliary Modules



UDACT-300A Digital Alarm Communicator Module

The UDACT-300A Digital Alarm Communicator allows the system to transmit addressable point information to a central station. The UDACT-300A occupies one module slot.



PR-300 Polarity Reversal/City Tie Module

The PR-300 Polarity Reversal/City Tie Module provides the system with a supervised City Tie (24 VDC/200 mA max.) and Polarity Reversal connection (24 VDC (open circuit), 8 mA max. (shorted)). The PR-300 occupies one module slot.

Remote LCD Annunciators

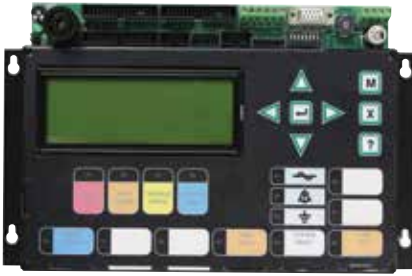

RAXN-LCD Remote LCD Annunciator

The RAXN-LCD Remote LCD Annunciator is equipped with a 4 line x 20 character back-lit alphanumeric LCD display that provides an exact replica of the main FleX-Net fire alarm control panel display. The RAXN-LCD occupies one display position in the BB-1000 or BB-5000 Series enclosures.



RAXN-LCDG Remote Graphic LCD Annunciator

The RAXN-LCDG Remote Graphic LCD Annunciator is equipped with a 24 line x 40 character back-lit graphical LCD display that is used to display 9 events per page. Each event is displayed over 2 lines with 40 characters per line allowing emergency information to be displayed in an easy to read format. The RAXN-LCDG occupies one display position in the BB-1000 or BB-5000 Series enclosures.

Remote LED Annunciators



RAM-1032TZDS Main Remote LED Annunciator

The RAM-1032TZDS Main Remote LED Annunciator provides common annunciator functions and 32 points of LED annunciation. The RAM-1032TZDS has indicators for A.C. On, Common Trouble and Signal Silence and controls for System Reset, Lamp Test, Fire Drill, Buzzer Silence and Signal Silence. The RAM-1032TZDS occupies one display position in the BB-1000 or BB-5000 enclosures.



RAX-1048TZDS Programmable LED Annunciator Module

The RAX-1048TZDS Programmable LED Annunciator Module provides 48 programmable bi-colored LEDs. The RAX-1048TZDS connects to the main panel or either the RAXN-LCD or RAM-1032TZDS when mounted remotely. The RAX-1048TZDS occupies one display position in the BB-1000 or BB-5000 Series enclosures.

Graphic Annunciator Driver Modules



MGD-32 Master Graphic Driver Module

The MGD-32 Master Graphic Driver Module provides common control inputs for the common control switches such as System Reset, Signal Silence, Auxiliary Disconnect, Fire Drill, Lamp Test, Acknowledge and General Alarm. The MGD-32 can also drive up to 32 supervised outputs. These output points are capable of driving LEDs or incandescent lamps. The MGD-32 mounts in a graphic annunciator wallbox or in the BB-5000 enclosures. An external power supply is required for incandescent lamps and lamp test.



AGD-048 Adder Graphic Driver Module

The AGD-048 Adder Graphic Driver Module can be used with the MGD-32 to support an additional 48 supervised outputs. The AGD-048 mounts in a graphic annunciator wallbox or in the BB-5000 Series enclosures.

Programmable Modules



FDX-008 Fan Damper Control Module

The FDX-008 Fan Damper Control Module provides individually programmed circuits which can be used for fan or damper control. The FDX-008 connects to the main panel or the RAXN-LCD and occupies one display position in the BB-1000 or BB-5000 Series enclosures.

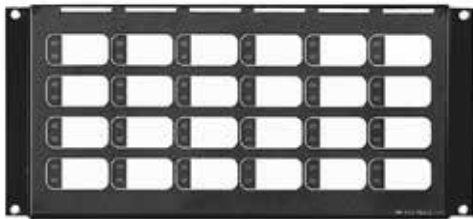

IPS-2424DS Programmable Input Switches Module

The IPS-2424DS provides 24 programmable switches that can be configured for ancillary functions such as zone bypass or added common control functions. The IPS-2424DS connects to main panel or the RAXN-LCD when mounted remotely. The IPS-2424DS occupies one display position in the BB-1000 or BB-5000 Series enclosures.

Mounting Brackets



M500-BK9 Module Mounting Bracket

The M500-BK9 Module Mounting Bracket mounts inside the BB-5000 Series enclosures and provides space to mount up to nine M500 style intelligent modules.



M500-BK2 Module Mounting Bracket

The M500-BK2 Module Mounting Bracket mounts inside the BBX-FXMNS enclosure and provides space to mount up to two M500 style intelligent modules.

Graphics Software



Open Graphic Navigator (OpenGN)

Open Graphic Navigator (OpenGN) is a centralized fire alarm management system that provides building or campus monitoring. As a powerful integration tool, OpenGN allows operators to monitor remote sites from multiple workstations or smart phones located anywhere in the world. OpenGN displays monitored buildings and campuses in both 2D and 3D representations, and is highly customizable.

Dimensions for Annunciator Module Enclosures

Model	Dimensions
BB-1001D	9"H x 12.75"W x 1.85"D
BB-1002D	18"H x 12.75"W x 1.85"D
BB-1003D	26.4"H x 12.75"W x 1.85"D
BB-1008D	33"H x 22.5"W x 1.85"D
BB-1012D	45"H x 22.5"W x 1.85"D

FleX-Net Audio and Telephone Network Controller Modules



ANC-5000 Audio Network Controller Module

The ANC-5000 provides audio microphone control on the network system. The ANC-5000 mounts on a plate in the FX-2009-12NDS or QMB-5000N.



TNC-5000 Telephone Network Controller Module

The TNC-5000 provides five hardwired telephone circuits for the local floor panel with the first circuit configurable for the master telephone handset. The TNC-5000 mounts in the FX-2009-12NDS or QMB-5000N.

Paging & Telephone Control Modules



QMP-5101N Network Master Paging Control Module

The QMP-5101N Network Master Paging Control Module includes the paging microphone and common control indicators. The QMP-5101N allows for all call paging or selective paging with the QAZT-5302DS Zoned Paging and Telephone Selector Modules. The QMP-5101N occupies one module space in the BB-5000 Series enclosures.



QMT-5302N Network Master Firefighters' Telephone Control Module

The QMT-5302N includes the Master Telephone Handset and common control indicators. The QMT-5302N supports the QAZT-5302DS Paging and Telephone selector modules. The QMT-5302N occupies one module space in the BB-5000 Series enclosures.



QAZT-5302DS Zoned Paging/Telephone Selector Module

The QAZT-5302DS Zoned Paging and Telephone Selector Module includes 24 zone selector switches and LEDs. The QAZT-5302DS is used with the QMP-5101N Network Master Paging Control module or QMT-5302 Network Master Firefighters' Telephone module. Slide-in labels are provided to label the selector zones. The QAZT-5302DS occupies one module space in the BB-1000 or BB-5000 Series enclosures.

Audio Expansion



QBB-5001 Audio Backbox

The QBB-5001 holds one QMB-5000B Audio Motherboard and Card Cage, one QPS-5000N Audio Power Supply, one QBC-5000N Audio Battery Charger and up to 40 Ah batteries.

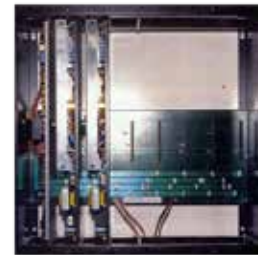

QMB-5000B Audio Motherboard and Card Cage

The QMB-5000B supports 7 QAA style audio amplifiers. The QMB-5000B requires one QPS-5000N Audio Power Supply and one QBC-5000N Audio Battery Charger and mounts in the QBB-5001 backbox.



QPS-5000N Audio Power Supply

The QPS-5000N supports up to 360 watts and mounts in the QBB-5001 Audio backbox.



QBC-5000N Audio Battery Charger

The QBC-5000N will charge up to 65 Ah batteries and mounts in QBB-5001 Audio Backbox.

Note: The QBB-5001 Audio Backbox will hold up to 40 Ah batteries. Larger batteries will require a BC-160 Battery Cabinet.

Audio Amplifiers



QAA-5415-70 and QAA-5415-25 Quad 15 Watt Amplifiers

The QAA-5415-70 and QAA-5415-25 consist of four 15 watt supervised paging/speaker circuits which can be wired in Class 'B' (Style 'Y') only. The QAA-5415-70 is a 70 Volt amplifier and the QAA-5415-25 is a 25 Volt amplifier. Both models mount in either the QMB-5000N or QMB-5000B card cage and occupy one amplifier slot.

QAA-5230S-70/25 Dual 30 Watt Amplifier

The QAA-5230S-70/25 consists of two 25 or 70 Volt 30 watt amplifiers. Each amplifier has two 15 watt supervised speaker outputs which are used for 'A' 'B' speakers per floor and are wired in Class 'B' (Style 'Y') only. The QAA-5230S-70/25 mounts in either the QMB-5000N or QMB-5000B card cage and occupies one amplifier slot.

QAA-5230-70/25 Dual 30 Watt Amplifier

The QAA-5230-70/25 consists of two 25 or 70 Volt 30 watt supervised paging/speaker circuits which can be wired in Class 'A' (Style 'Z') or Class 'B' (Style 'Y'). The QAA-5230-70/25 mounts in either the QMB-5000N or QMB-5000B card cage and occupies one amplifier slot.

QAA-5160-70/25 60 Watt Amplifier

The QAA-5160-70/25 consists of one 25 or 70 Volt 60 watt supervised paging/speaker circuit which can be wired in Class 'A' (Style 'Z') or Class 'B' (Style 'Y'). The QAA-5160-70/25 mounts in either the QMB-5000N or QMB-5000B card cage and occupies one amplifier slot.

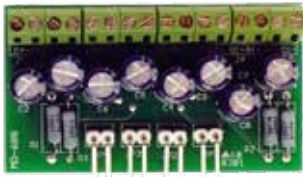

QAA-4CLA Class 'A' (Style 'Z') Converter Module

The QAA-4CLA converts each of the four Class 'B' (Style 'Y') outputs on a QAA-5415-70 or QAA-5415-25 Amplifiers to Class 'A' (Style 'Z'). The module attaches to the bottom of the amplifier. One QAA-4CLA is required for each amplifier.

QAA-4CLAS Class 'A' (Style 'Z') Converter Module

The QAA-4CLAS converts each of the four Class 'B' (Style 'Y') outputs on a QAA-5230S-70/25 or QAA-5230S-525-70/25 Amplifier to Class 'A' (Style 'Z'). The module attaches to the bottom of the amplifier. One QAA-4CLAS is required for each amplifier.

QAA 5415-70 or QAA-5415-25 Wiring Diagram

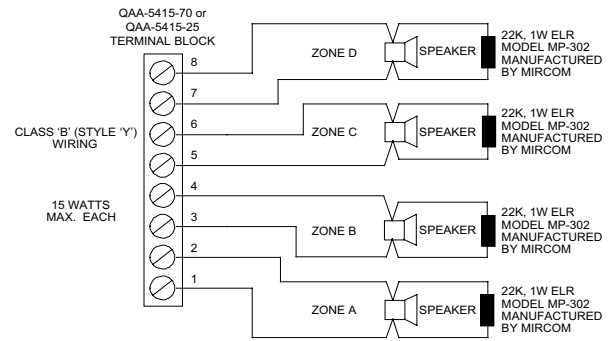

QAA-5230S-70/25 Wiring Diagram

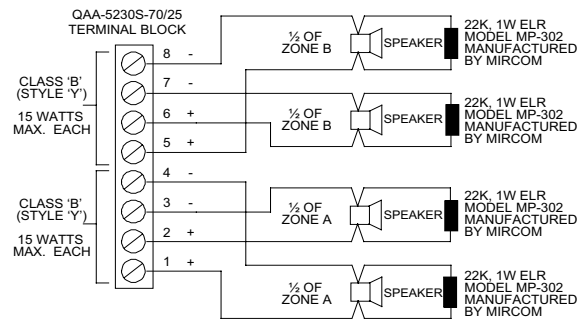

QAA-5230-70/25 Wiring Diagram

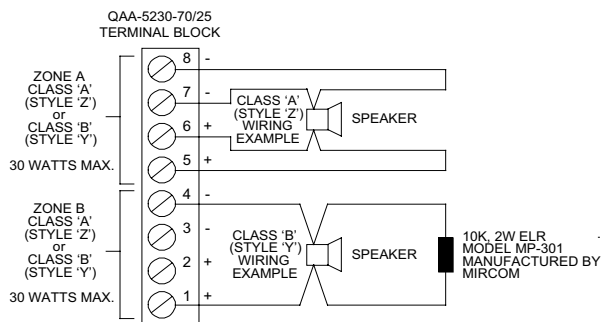

QAA-5160-70/25 Wiring Diagram

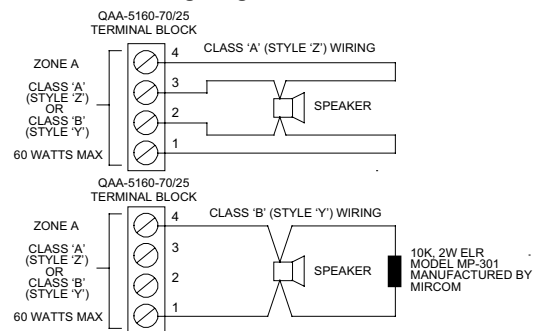

QAA-4CLA and QAA-4CLAS Connection Diagram

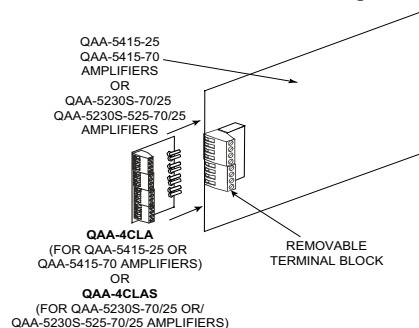

Typical FleX-Net Networked System Configuration with Audio

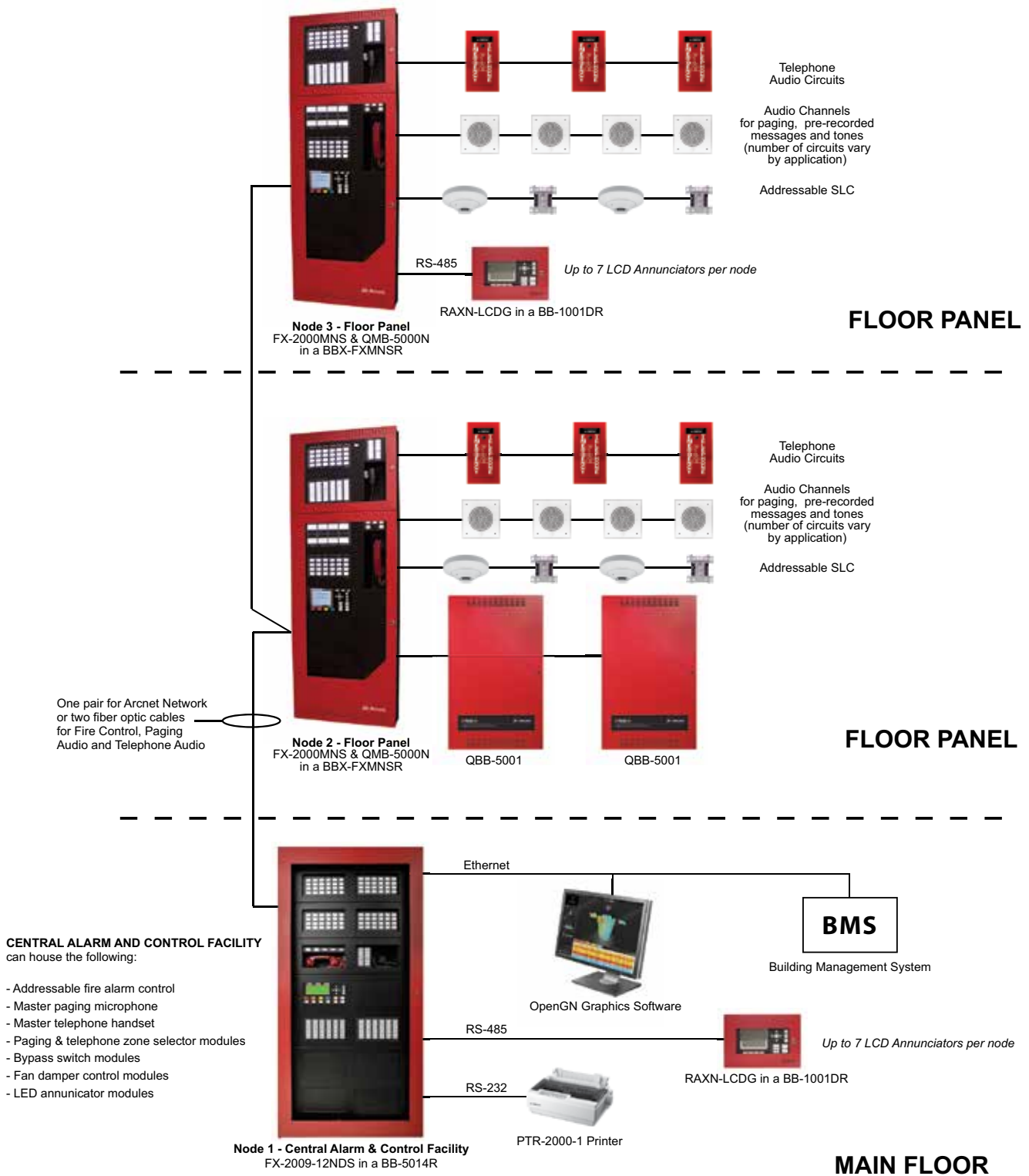

Current Consumption

Model Number	Description	Standby (Amps)	Alarm (Amps)
Fire Alarm Components			
FX-2000MNS	Main Network Control Unit on a Chassis (12 Amp)	0.310	0.733
FX-2003-12NDS	Compact Main Network Control Unit (12 Amp)	0.310	0.733
FX-2017-12NDS	Mid-Size Main Network Control Unit (12 Amp)	0.310	0.733
FX-2009-12NDS	Large Main Network Control Unit (12 Amp)	0.310	0.733
ALCN-792MISO	Isolated Quad Loop Controller Module	0.130	0.145
ALCN-792MISO /w ALCN-792D	Isolated Quad Loop Controller Module with Daughter Module	0.130	0.145
FNC-2000	Fire Network Controller Module	0.190	0.0190
ANC-5000	Audio Network Controller Module	0.255	0.265
TNC-5000	Telephone Network Controller Module	0.195	0.215
FOM-2000-SP	Fiber Optics Module	0.015	0.015
DM-1008A	8 Initiating Circuit Module	0.080	1 zone active: 0.125 2 zone active: 0.170 4 zone active: 0.275 6 zone active: 0.370 8 zone active: 0.465
SGM-1004S	4 Notification Appliance Circuit Module	0.031	0.096
RM-1008A	8 Relay Circuit Module	0.025	0.150
FDX-008	Fan Damper Control Module	0.015	0.035
DSPL-420	Narrow Display	0.024	0.025
DSPL-420-16TZDS	Narrow Display w/ additional 16 LED Zones	0.010	0.046
DSPL-2440	Graphic Display	0.029	0.035
UDACT-300A	Dialer Module	0.045	0.120
PR-300	City Tie Module	0.035	0.300
FDS-008	Selection Control Panel for MNS	0.024	0.112
RAX-1048TZDS	Adder Annunciator Chassis	0.022	1 zone active: 0.026 2 zone active: 0.030 3 zone active: 0.035 4 zone active: 0.039 48 zone active: 0.262
RAM-1032TZDS	Adder Annunciator Chassis	0.050	32 zone active: 0.300
MGD-32	Main Graphic Driver Module	0.035	1.6
AGD-048	Adder Graphic Driver Module	0.035	# of LEDs x 4mA
IPS-2424DS	Programmable Input Switches Module	0.010	0.015
Audio Components			
ANC-5000	Audio Network Controller Module	0.255	0.265
TNC-5000	Telephone Network Controller Module	0.195	0.215
QAA-5160-70/25	1 Zone 60W Amplifier	0.055	0.350
QAA-5230-70/25	2 Zone 30W Amplifier	0.055	0.350
QAA-5230S-70/25	2 Zone 30W Amplifier (split)	0.055	0.350
QAA-5415-70	4 Zone 15W Amplifier, 70V	0.055	0.350
QAA-5415-25	4 Zone 15W Amplifier, 25V	0.055	0.350
QMP-5101N	Master Paging Module	0.004	0.012
QMP-5101NV	Vertical Master Paging Module	0.004	0.012
QMT-5302N	Master Telephone Module	0.003	0.013
QMT-5302NV	Vertical Master Telephone Module	0.003	0.013
QAZT-5302DS	Paging/Telephone Zone Module	0.010	0.015

Ordering Information

Model	Description
FleX-Net Network Lobby Control and Floor Panels - Integrated Fire and Audio Systems	
FX-2009-12NDS	Large Network Main Control Unit. Mounts in the BB-5000 series enclosures.
ECX-0012	Expander Chassis for the FX-2009-12NDS. Mounts in the BB-5000 series enclosures.
FX-2000MNS	Main Network Board with one SLC loop. Mounts in the BBX-FXMNS enclosure.
DSPL-420	4 x 20 Main LCD Display for FX-2000MNS
DSPL-420-16TZDS	4 x 20 Main LCD Display for FX-2000MNS w/16 LEDs
DSPL-2440	Graphical Main Display for FX-2000MNS
QMB-5000N	Integrated Audio Network Control Chassis
PS-2040	Network Fire Alarm and Audio Power Supply
Enclosures	
BB-5008	Lobby Control Wallbox Enclosure. Supports 8 Module Footprints.
DOX-5008M	White Metal Door for BB-5008. Add suffix 'R' for red enclosure.
CCH-5008	Custom Mounting Kit for BB-5008. One required per BB-5008.
CCH-5008G	Custom Mounting Kit for BB-5008, Required when using RAXN-LCDG as Main Display
BB-5014	Lobby Control Wallbox Enclosure. Supports 14 Module Footprints.
DOX-5014M	White Metal Door for BB-5014. Add suffix 'R' for red enclosure.
CCH-5014	Custom Mounting Kit for BB-5014. One required per BB-5014.
BBX-FXMNS	Black backbox enclosure with white doors for FX-2000MNS. Add suffix 'R' for red doors.
BBX-MNSXP	Extension Audio Signaling Cabinet, white door. Add suffix 'R' for red doors.
Adder Loop Controller Modules	
ALCN-792MISO	Network Isolated Quad Loop Controller Module
ALCN-792D	Daughter board for ALC-792MISO Isolated Quad Loop Controller Module
Adder Hardwire Modules	
DM-1008A	Eight Class B (Style B) or 4 Class A (Style D) Initiating Circuit Module
SGM-1004S	Four Class A/B (Style Z/Y) Notification Appliance Circuit Module (Rated at 1.7 Amps per circuit)
RM-1008A	Eight Relay Circuit Module c/w eight form C relays (Rated for 28 VDC @ 1 Amp max. per relay)
Adder Auxiliary Modules	
UDACT-300A	Digital Alarm Communicator Transmitter/Dialer Module
PR-300	Polarity Reversal and City Tie Module
Programmable Modules	
IPS-2424DS	Programmable Input Switches Module c/w 24 selector switches and 24 bi-coloured LEDs
FDX-008	Fan Damper Control Module c/w 8 programmable switches
Power Module	
INX-10AC	Internal Booster Power Supply Module
Remote Annunciators	
RAXN-LCD	Remote LCD Annunciator
RAXN-LCDG	Remote Graphic LCD Annunciator
RAM-1032TZDS	Main Remote LED Annunciator c/w 32 Bi-Colored LEDs
RAX-1048TZDS	Adder Annunciator Chassis c/w 48 Bi-Colored LEDs
Graphic Annunciator Driver Modules	
MGD-32	Main Graphic Driver Module c/w 32 Supervised Outputs
AGD-048	Adder Graphic Driver Module c/w 48 Supervised Outputs
Network Controller Modules	
FNC-2000	Fire Network Controller Module
FOM-2000-SP	Fiber Optic Network Adder Module
ANC-5000	Audio Network Controller Module
TNC-5000	Telephone Network Controller Module

Paging and Telephone Control Modules	
QMP-5101NV	Master Network Paging Control Module for FXMNS, Vertical Mount. For use in BBX-FXMNS.
QMT-5302NV	Master Network Telephone Module for FXMNS, Vertical Mount. For use in BBX-FXMNS.
QMP-5101N	Master Network Paging Control Module
QMT-5302N	Master Network Telephone Control Module
QAZT-5302DS	Paging and Telephone Selector Panel
Audio Amplifiers	
QAA-5415-70	70 Volt Quad 15 Watt Amplifier
QAA-5415-25	25 Volt Quad 15 Watt Amplifier
QAA-4CLA	Class 'A' (Style 'Z') Converter Module for QAA-5415-25 and QAA-5415-70 Amplifiers
QAA-5230S-70/25	25 or 70 Volt Dual 30 Watt Amplifier split 'A' 'B' circuits per floor
QAA-4CLAS	Class 'A' (Style 'Z') Converter Module for QAA-5230S-70/25 and QAA-5230S-525-70/25
QAA-5230-70/25	25 or 70 Volt Dual 30 Watt Amplifier
QAA-5160-70/25	25 or 70 Volt 60 Watt Amplifier
Enclosures for Remote Annunciators / Programmable Modules	
BB-1001D	Remote Annunciator/Programmable Module Enclosure Houses one module. Add suffix "R" for red door.
BB-1002D	Remote Annunciator/Programmable Module Enclosure Houses two modules. Add suffix "R" for red door.
BB-1003D	Remote Annunciator/Programmable Module Enclosure Houses three modules. Add suffix "R" for red door.
BB-1008D	Remote Annunciator/Programmable Module Enclosure Houses eight modules. Add suffix "R" for red door.
BB-1012D	Remote Annunciator/Programmable Module Enclosure Houses twelve modules. Add suffix "R" for red door.
Audio Expansion Components	
QMB-5000B	Audio Motherboard and Card Cage
QPS-5000N	Audio Power Supply
QBC-5000N	Audio Battery Charger
QBB-5001	Audio Backbox
Graphics Software	
CONNECT-1	License for single node/panel, comes with XML Adapter software, up to 10,000 devices/objects
CONNECT-5	License for up to (5) nodes/panels, comes with XML Adapter software, up to 50,000 devices/objects
CONNECT-10	License for up to (10) nodes/panels, comes with XML Adapter software, up to 100,000 devices/objects
ENTERPRISE-120	License for up to (120) nodes/panels, comes with XML Adapter software, unlimited devices/objects
Accessories	
MGC NTKW SRVC KIT	New installation or service kit comprised of common cables, inserts and hardware
MGC-FACP-CFG-KIT1	Fire Alarm Control Panel Configuration Kit 1



Canada

25 Interchange Way Vaughan, ON L4K 5W3
 Telephone: (905) 660-4655 | Fax: (905) 660-4113

U.S.A.

4575 Witmer Industrial Estates Niagara Falls, NY 14305
 Toll Free: (888) 660-4655 | Fax Toll Free: (888) 660-4113

www.mircom.com



This document is provided by Mircom Technologies Ltd., MGC Systems Corp., or their affiliates, subsidiaries and brands, for convenience or marketing only and does not describe products or services technically. For technical information refer to technical manuals. We do not make representations or warranties regarding this information, including as to completeness or accuracy. We may change these contents at any time and reserve all rights in the contents, including copyrights, trademarks and other intellectual property.