



Description

The NC-500 Pendant is a water-resistant wearable emergency call device that can be used anywhere in a MiCare facility. Motion sensors and fast transmit times ensure long lasting battery life, and the battery is user-serviceable. Included is an attractive breakaway lanyard and rubberized jacket, which can be removed for easy cleaning. It also includes a window for a picture.

Cancel at source options include magnetic activation for facilities requiring an attendant to be present when cancelling a call.

A highly sensitive ultrasonic receiver built into the pendant allows for 100% locating accuracy anywhere in the building. The resident's location is displayed prominently on a facility map using a simple web browser via smart phones, tablets or PC's.

Features

- Water-resistant.
- Breakaway lanyard.
- LED indicator.
- Long battery life with a standard CR2450 battery.
- Batteries are easily changed by maintenance staff.
- Low battery indicator which routes to special reports for maintenance staff.
- Can be worn anywhere in the facility.
- Fully supervised heartbeats to Central ensure 24/7 operation.
- Accurate locating with the facility.
- Cancel at source.

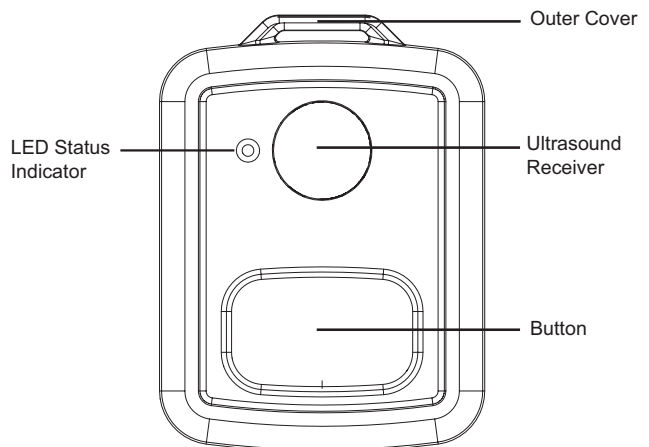

Technical Specifications

Standards:	UL 1069, 2560, CSA 22.2 #205, FCC Part 15, Class "B", CS-03
Power Options:	Input Power: <ul style="list-style-type: none"> • 1 x 3 V CR2450 Battery • Capacity: 540 mAh • Nominal Current: 10 µA • Transmit Current: 35 mA • Receive Current: 25 mA • Transmit and Receive Frequency: 4 times a day
Wireless Characteristics:	ZigBee: <ul style="list-style-type: none"> • Frequency: 2.4 GHz • Network type: 802.15.4 wireless mesh network • Range: 23 m (75 ft) with indoor line of sight Ultrasonic receiver: <ul style="list-style-type: none"> • Frequency: 40 kHz • Range: 9.1 m (30 ft)
Physical Characteristics:	Enclosure: Germ-Wipeable Plastic Color: White & Blue Weight: 25g (0.9 oz) Dimensions: 46 mm x 38 mm x 13 mm (1.8" H x 1.5" W x 0.5" D) Operating Temperature: -10°C to +50°C (14°F to 122°F)

Ordering Information

Model	Description
NC-500	Pendant

NOT TO BE USED FOR INSTALLATION PURPOSES.



Canada
25 Interchange Way
Vaughan, Ontario L4K 5W3
Telephone: (905) 660-4655
Fax: (905) 660-4113

U.S.A.
4575 Witmer Industrial Estates
Niagara Falls, NY 14305
Toll Free: (888) 660-4655
Fax Toll Free: (888) 660-4113

Distributed by:

