



Description

The NC-2100K Coordinator Bundle is part of the advanced nurse call solution that couples mesh networking technology with ultrasonic signaling to accurately identify and respond to emergency events. Forming the backbone of the highly reliable 802.15.4 wireless network, this network gateway provides a self-forming, self-healing “mesh” type transport to route messages to/from all MiCare devices.

Bridging the connection from our Central Software and emergency devices, the gateway enables extended coverage, device monitoring, real time communications and enhanced notifications with web enabled visual displays.

Features

- Dual redundant gateway modules with hot standby for continuous operation.
- Options for direct connection to MiCare Central Server or remote placement in key areas of a facility.
- Full supervision on both gateway modules and USB connections from a centralized application.
- Able to manage hundreds of devices.
- LED status indicators for traffic and active gateway operation.

Standard Kit Includes:

- 1pcs NC-2100K (Coordinator Bundle)
- 2pcs NC-P24VDC (24Vdc Power Supply)
- 2pcs NC-P24VDCCORD (AC Power Cord)
- 2pcs MD-813 (6' USB Cable)
- 2pcs Mounting Brackets with 4pcs Screws

Technical Specifications

Standards:	UL 1069, 2560, CSA 22.2 #205, FCC Part 15/Part 68, Class "B", CS-03
Power Options: (Power Options per Input)	Input Power: <ul style="list-style-type: none"> • Range: 24V-48V AC/DC polarity independent • Nominal Current 35 mA
Wireless Characteristics:	ZigBee: <ul style="list-style-type: none"> • Frequency: 2.4 GHz • Network type: 802.15.4 wireless mesh network • Range: 23 m (75 ft) with indoor line of sight Ultrasonic transmitter: <ul style="list-style-type: none"> • Frequency: 40 kHz • Range: 9.1 m (30 ft)
Physical Characteristics:	Enclosure: Plastic Color: Black Weight: 1.18 kg (2.6 lb) (1U) 1.86 kg (4.1 lb) (2U) Dimensions: 44 mm x 438 mm x 206 mm (1.75" H x 17.25" W x 8.1" D) (1U) 86 mm x 483 mm x 211 mm (3.4" H x 19" W x 8.3" D) (2U) Operating Temperature: 0° C to +50° C (32° F to 122° F)

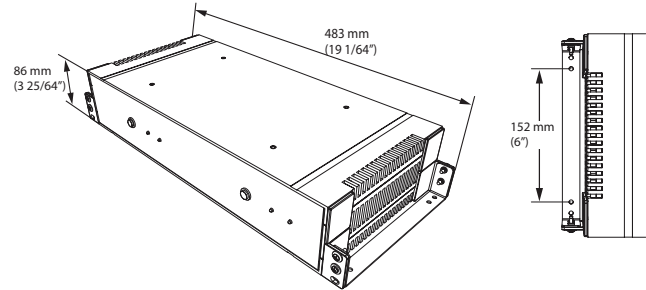
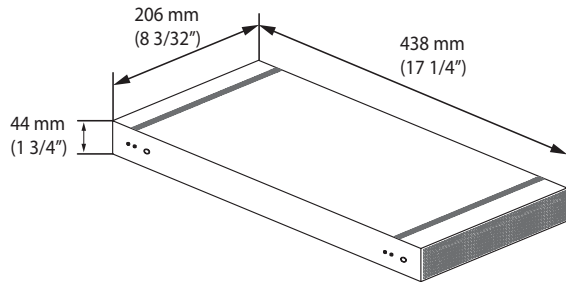

Typical Wire Connections Block Diagram – Option 1:

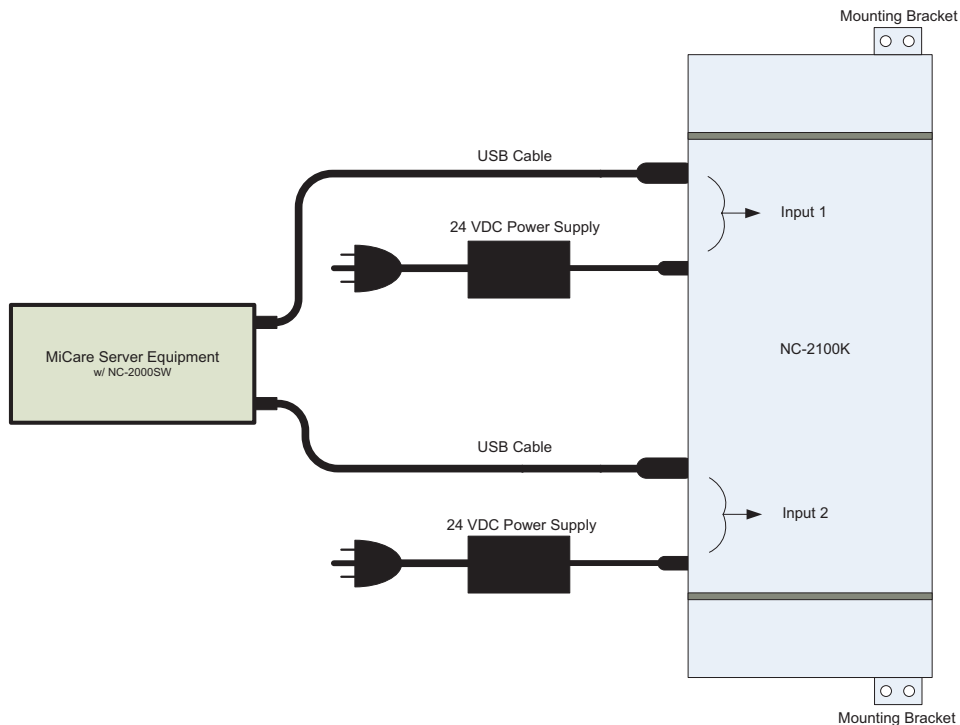

NOT TO BE USED FOR INSTALLATION PURPOSES.

Typical Wire Connections Block Diagram – Option 2:

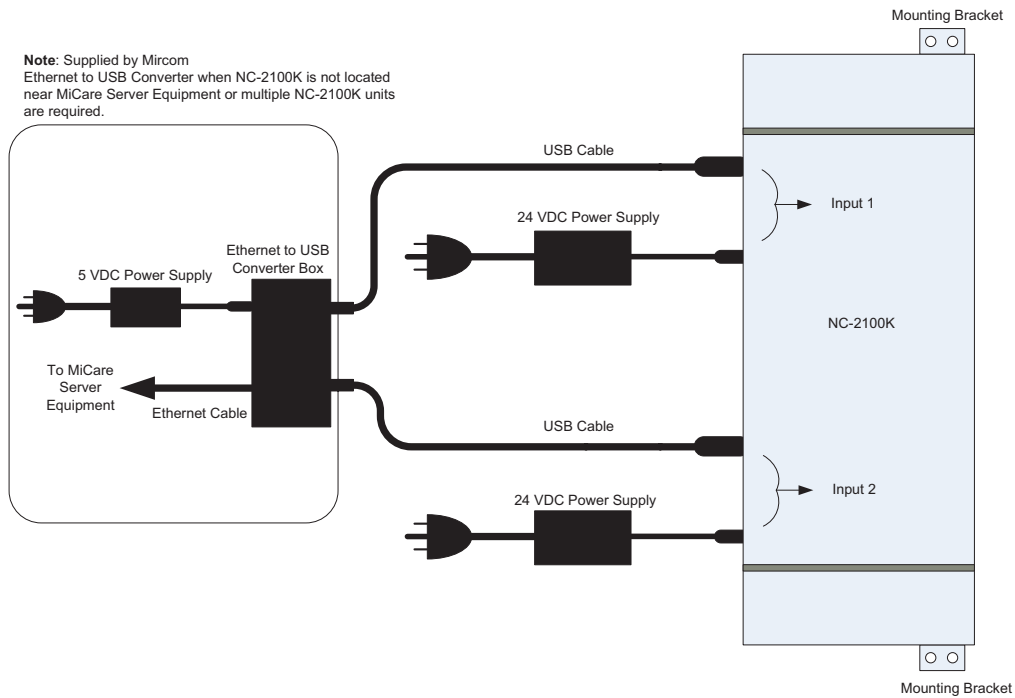

Ordering Information

Model	Description
NC-2100K	Coordinator Bundle Kit

NOT TO BE USED FOR INSTALLATION PURPOSES.



Canada
25 Interchange Way
Vaughan, Ontario L4K 5W3
Telephone: (905) 660-4655
Fax: (905) 660-4113

U.S.A.
4575 Witmer Industrial Estates
Niagara Falls, NY 14305
Toll Free: (888) 660-4655
Fax Toll Free: (888) 660-4113

Web page: <http://www.mircomgroup.com> Email: mail@mircomgroup.com

Distributed by:

ISO 9001:2008
REGISTERED



CAT. 9206
Rev 2