



25 Interchange Way,
Vaughan, Ontario L4K-5W3
905-660-4655, FAX: 905-660-4113

MIX-5251APA, MIX-5251RAPA and MIX-5251HAPA Intelligent Plug-In Temperature Sensors

SPECIFICATIONS

Diameter:	6.1 inches (155 mm) installed in B210LPA; 4.1 inches (104 mm) installed in B501A
Height:	2.0 inches (51 mm)
Weight:	4.8 ounces (137 gm)
Installation Temperatures:	-4°F to 100°F (-20°C to 38°C); MIX-5251APA and MIX-5251RAPA; -4°F to 150°F (-20°C to 66°C); MIX-5251HAPA
Operating Humidity Range:	10% to 93% Relative Humidity Non-condensing
Mounting:	B210LPA flanged base; B501A flangeless base
Voltage Range:	15 to 32 Volts DC Peak
Standby Current:	300 µA @ 24 VDC (one communication every 5 seconds with LED blink enabled)
LED Current:	6.5 mA @ 24 VDC
Fixed Temperature Rating:	135°F (57°C); MIX-5251APA and MIX-5251RAPA; 190°F (88°C); MIX-5251HAPA
Rate of Rise Detection:	Responds to greater than 15°F/min.; MIX-5251RAPA

BEFORE INSTALLING

This sensor must be installed in compliance with the control panel system installation manual. The installation must meet the requirements of the Authority Having Jurisdiction (AHJ). Sensors offer maximum performance when installed in compliance with CAN/ULC-S524.

Please read the system wiring and installation manual thoroughly. This manual provides detailed information on sensor spacing, placement, zoning, and special applications. Copies of these manuals are available from Mircom.

GENERAL DESCRIPTION

Models MIX-5251APA, MIX-5251RAPA and MIX-5251HAPA are intelligent sensors that utilize a state-of-the-art thermistor sensing circuit for fast response. These sensors are designed to provide open area protection with 50 foot spacing capability as approved by ULC. Model MIX-5251APA is a fixed temperature sensor with 135°F fixed temperature alarm. Model MIX-5251RAPA is a rate-of-rise temperature sensor with 135°F fixed temperature alarm. Model MIX-5251HAPA is a high temperature sensor with 190°F fixed temperature alarm.

Two LEDs on each sensor light to provide 360° visibility of the sensor indication. The LEDs can be latched ON by code command from the panel for an alarm indication. The LEDs can also be unlatched to the normal condition by code command. Remote LED annunciator capability is available as an optional accessory (Part No. RA400ZA/RA100ZA).

Models MIX-5251APA, MIX-5251RAPA and MIX-5251HAPA require compatible addressable communications to function properly. Connect these sensors to listed-compatible control panels only.

WIRING GUIDE

All wiring must be installed in compliance with the Canadian Electrical Code, applicable local codes and the Authority Having Jurisdiction. Proper wire gauges should be used. The installation wires should be color coded to limit wiring mistakes and ease system troubleshooting. Improper connections will prevent a system from responding properly in the event of a fire.

Remove power from the communication line before installing sensors.

1. Wire the sensor base (supplied separately) per the wiring diagram, see Figure 1.
2. Set the desired address on the sensor address switches, see Figure 2.
3. Install the sensor into the sensor base. Push the sensor into the base while turning it clockwise to secure it in place.
4. After all sensors have been installed, apply power to the control unit and activate the communication line.
5. Test the sensor(s) as described in the TESTING section of this manual.

TAMPER RESISTANCE

The sensor bases have a tamper-resistant capability. When this capability is enabled, sensors cannot be removed from the base without the use of a small screwdriver or other similar tool. Refer to the sensor base installation instruc-

tion manual for details in using this capability.

TESTING

Before testing, notify the proper authorities that the system is undergoing maintenance, and will temporarily be out of service. Disable the system to prevent unwanted alarms.

All sensors must be tested after installation and periodically thereafter. Testing methods must satisfy the Authority Having Jurisdiction (AHJ). Sensors offer maximum performance when tested and maintained in compliance with CAN/ULC-S536. The sensor may be tested in the following ways:

A. TEST MAGNET (MODEL NO. M02-04)

1. Place the magnet against the cover in the magnet test area as shown in Figure 3 to activate the test feature.
2. The LEDs should latch ON within 10 seconds, indicating alarm and annunciating the panel.
3. Reset the detector at the system control panel.

B. DIRECT HEAT METHOD (HAIR DRYER OF 1000 – 1500 WATTS)

1. From the side of the detector, direct the heat toward the sensor. Hold the heat source about 6 inches (15cm) away to prevent damage to the cover during testing.
2. The LEDs on the detector should light when the temperature at the detector reaches the alarm set point. If the LEDs fail to light, check the power to the detector and the wiring in the detector base.
3. Reset the detector at the system control panel.

Detectors that fail these tests should be cleaned as described under MAINTENANCE and retested. If the detectors still fail these tests they should be returned for repair.

MAINTENANCE

NOTE: Before cleaning notify the proper authorities that the system is undergoing maintenance, and therefore the system will temporarily be out of service. Disable the loop or system undergoing maintenance to prevent unwanted alarms.

It is recommended that the sensor be removed from its mounting base for easier cleaning and that sensors be cleaned at least once a year. Use a vacuum cleaner to remove dust from the sensing chamber.

FIGURE 1:

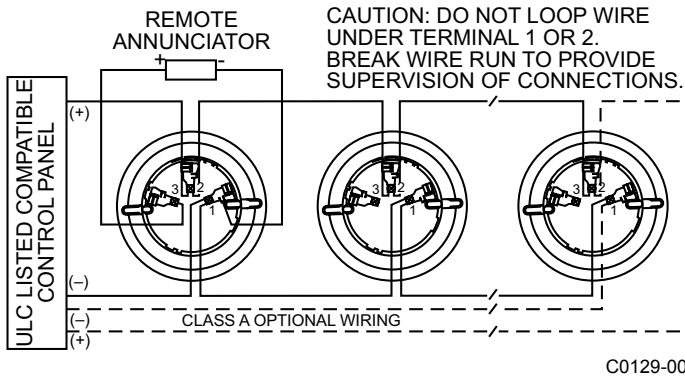

FIGURE 2. ROTARY DECADE ADDRESS SWITCHES:

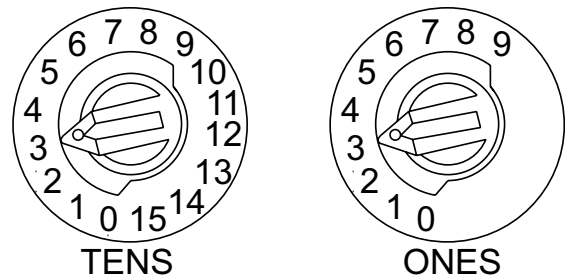

FIGURE 3. VIEWS SHOWING POSITION OF TEST MAGNET.:

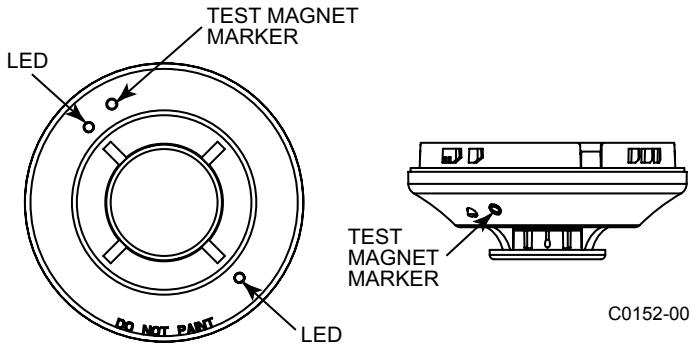
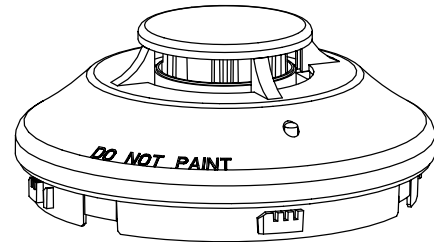

FIGURE 4:



FM CLASSIFICATION

RTI ratings are for installations which must comply with FM 3210.

MIX-5251APA RTI:	FAST
MIX-5251RAPA RTI:	V2-FAST
MIX-5251HAPA RTI:	QUICK

Please refer to insert for the Limitations of Fire Alarm Systems

THREE-YEAR LIMITED WARRANTY

Mircom warrants its enclosed heat detector to be free from defects in materials and workmanship under normal use and service for a period of three years from date of manufacture. Mircom makes no other express warranty for this heat detector. No agent, representative, dealer, or employee of the Company has the authority to increase or alter the obligations or limitations of this Warranty. The Company's obligation of this Warranty shall be limited to the repair or replacement of any part of the heat detector which is found to be defective in materials or workmanship under normal use and service during the three year period commencing with the date of manufacture. After phoning Mircom's number 905-660-4655 for a Return Authorization number, send defective units post-age prepaid to: Mircom, Returns Department, RA # _____, 25 Interchange Way,

Vaughan, Ontario L4K-5W3. Please include a note describing the malfunction and suspected cause of failure. The Company shall not be obligated to repair or replace units which are found to be defective because of damage, unreasonable use, modifications, or alterations occurring after the date of manufacture. In no case shall the Company be liable for any consequential or incidental damages for breach of this or any other Warranty, expressed or implied whatsoever, even if the loss or damage is caused by the Company's negligence or fault. Some states do not allow the exclusion or limitation of incidental or consequential damages, so the above limitation or exclusion may not apply to you. This Warranty gives you specific legal rights, and you may also have other rights which vary from state to state.

FCC STATEMENT

This device complies with part 15 of the FCC Rules. Operation is subject to the following two conditions: (1) This device may not cause harmful interference, and (2) this device must accept any interference received, including interference that may cause undesired operation.

NOTE: This equipment has been tested and found to comply with the limits for a Class B digital device, pursuant to Part 15 of the FCC Rules. These limits are designed to provide reasonable protection against harmful interference in a residential installation. This equipment generates, uses and can radiate radio frequency energy and, if not installed and used in accordance with the instructions, may cause harmful interference to radio communications. However, there is no guarantee that interference will not occur in a particular installation. If this equipment does cause harmful interference to radio or television reception, which can be determined by turning the equipment off and on, the user is encouraged to try to correct the interference by one or more of the following measures:

- Reorient or relocate the receiving antenna.
- Increase the separation between the equipment and receiver.
- Connect the equipment into an outlet on a circuit different from that to which the receiver is connected.
- Consult the dealer or an experienced radio/TV technician for help.

This Class B digital apparatus complies with Canadian ICES-003