

MIX-M500SAPA Supervised Control Module

SPECIFICATIONS

Normal Operating Voltage:	15 to 32 VDC
Maximum Alarm Current:	6.5mA (LED On)
Average Operating Current:	400 µA max., 1 communication every 5 seconds 47k EOL resistor; 485uA max. (Communicating, NAC shorted).
Maximum NAC Line Loss:	4 VDC
External Supply Voltage (between Terminals T3 and T4)	
Maximum (NAC):	Regulated 24VDC
Maximum (Speakers):	70.07 V RMS, 50 W
Max. NAC Current Ratings:	For class B wiring system, the current rating is 3A; For class A wiring system, the current rating is 2A
Temperature Range:	32°F to 120°F (0°C to 49°C)
Humidity:	10% to 93% Non-condensing
Dimensions:	4 1/2" H x 4" W x 1 1/4" D (Mounts to a 4" square by 2 1/8" deep box.)
Accessories:	SMB500 Electrical Box; CB500 Barrier

BEFORE INSTALLING

This information is included as a quick reference installation guide. Refer to the control panel installation manual for detailed system information. If the modules will be installed in an existing operational system, inform the operator and local authority that the system will be temporarily out of service. Disconnect power to the control panel before installing the modules.

NOTICE: This manual should be left with the owner/user of this equipment.

GENERAL DESCRIPTION

MIX-M500SAPA Supervised Control Modules are intended for use in intelligent, two-wire systems, where the individual address of each module is selected using the built-in rotary decade switches. This module is used to switch an external power supply, which can be a DC power supply or an audio amplifier (up to 80 VRMS), to notification appliances. It also supervises the wiring to the connected loads and reports their status to the panel as NORMAL, OPEN, or SHORT CIRCUIT. The MIX-M500SAPA has two pairs of output termination points available for fault-tolerant wiring and a panel-controlled LED indicator.

COMPATIBILITY REQUIREMENTS

To ensure proper operation, these modules shall be connected to listed compatible system control panels only.

FIGURE 1. CONTROLS AND INDICATORS:

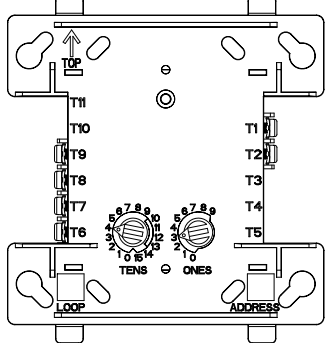
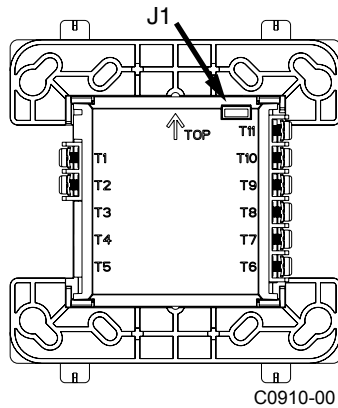

FIGURE 1B: JUMPER LOCATION



MOUNTING

The MIX-M500SAPA mounts directly to 4-inch square electrical boxes (see Figure 2A). The box must have a minimum depth of 2 1/8 inches. Surface mounted electrical boxes (SMB500) are available from Mircom.

FIGURE 2A. MODULE MOUNTING WITH BARRIER:

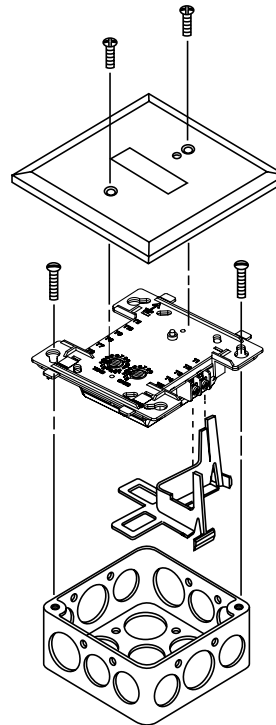
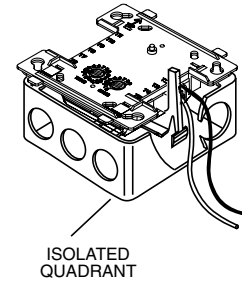

FIGURE 2B:



C1050-00

WIRING

NOTE: All wiring must conform to applicable local codes, ordinances, and regulations. When using control modules in nonpower limited applications, the Mircom CB500 Module Barrier must be used to meet UL requirements for the separation of power-limited and nonpower-limited terminals and wiring. The barrier must be inserted into a 4"×4"×2 1/8" junction box, and the control module must be placed into the barrier and attached to the junction box (Figure 2A). The power-limited wiring must be placed into the isolated quadrant of the module barrier (Figure 2B).

1. Install module wiring in accordance with the job drawings and appropriate wiring diagrams.
2. Set the address on the module per job drawings.
3. Secure module to electrical box (supplied by installer), as shown in Figure 2A.

IMPORTANT: When using the MIX-M500SAPA for fire fighter telephone applications, remove Jumper (J1) and discard. The Jumper is located on the back as shown in figure 1B. The module does not provide ring back when used as a fire fighter telephone circuit.

FIGURE 3. TYPICAL NOTIFICATION APPLIANCE CIRCUIT CONFIGURATION, NFPA STYLE Y:

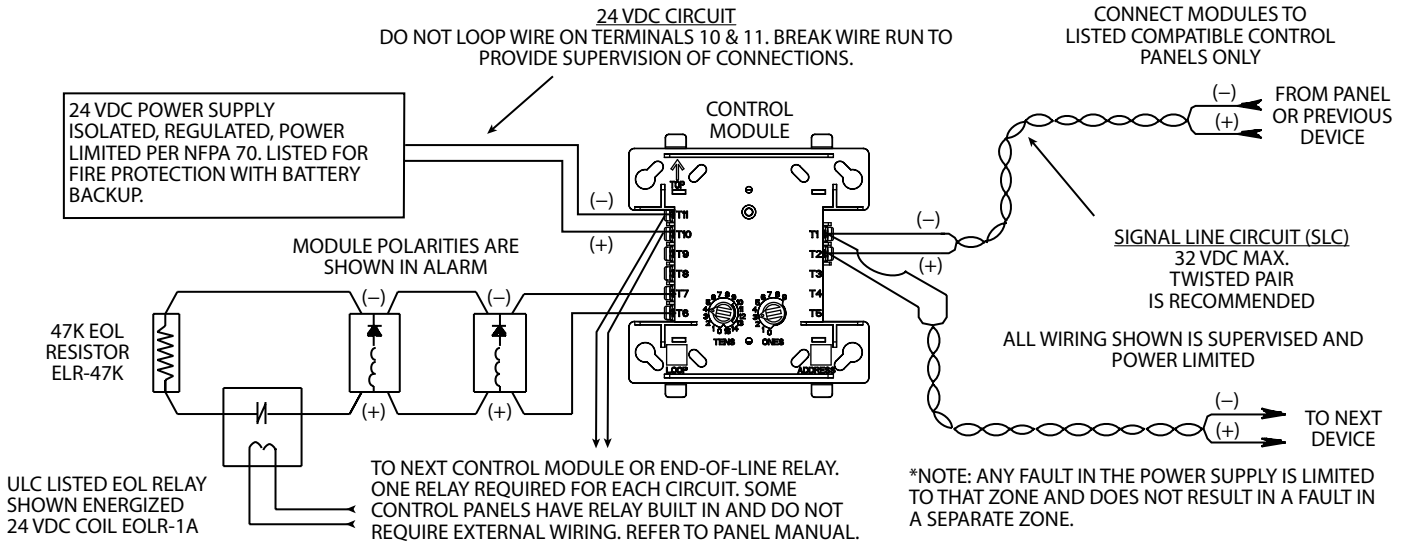

C0913-05

FIGURE 4. TYPICAL FAULT TOLERANT NOTIFICATION APPLIANCE CIRCUIT CONFIGURATION, NFPA STYLE Z:

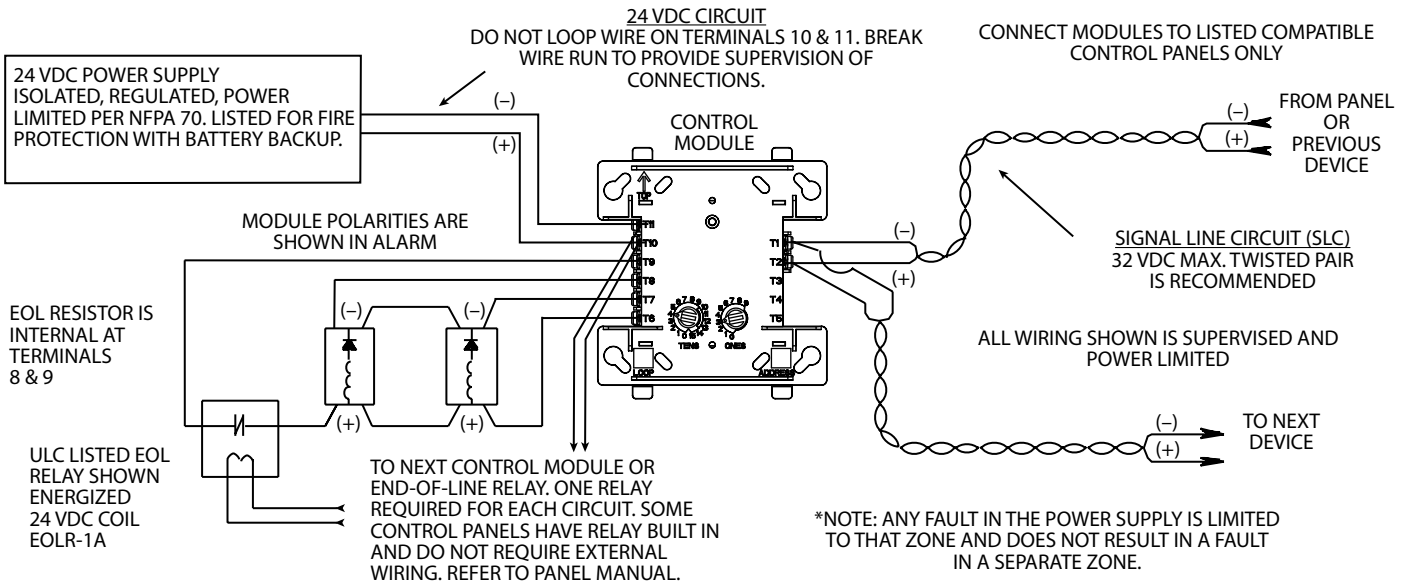

C0914-05

FIGURE 5. TYPICAL WIRING FOR SPEAKER SUPERVISION AND SWITCHING, NFPA STYLE Y:

AUDIO CIRCUIT WIRING MUST BE TWISTED PAIR AS A MINIMUM. SEE PANEL INSTALLATION MANUAL FOR DETAILED INFORMATION.

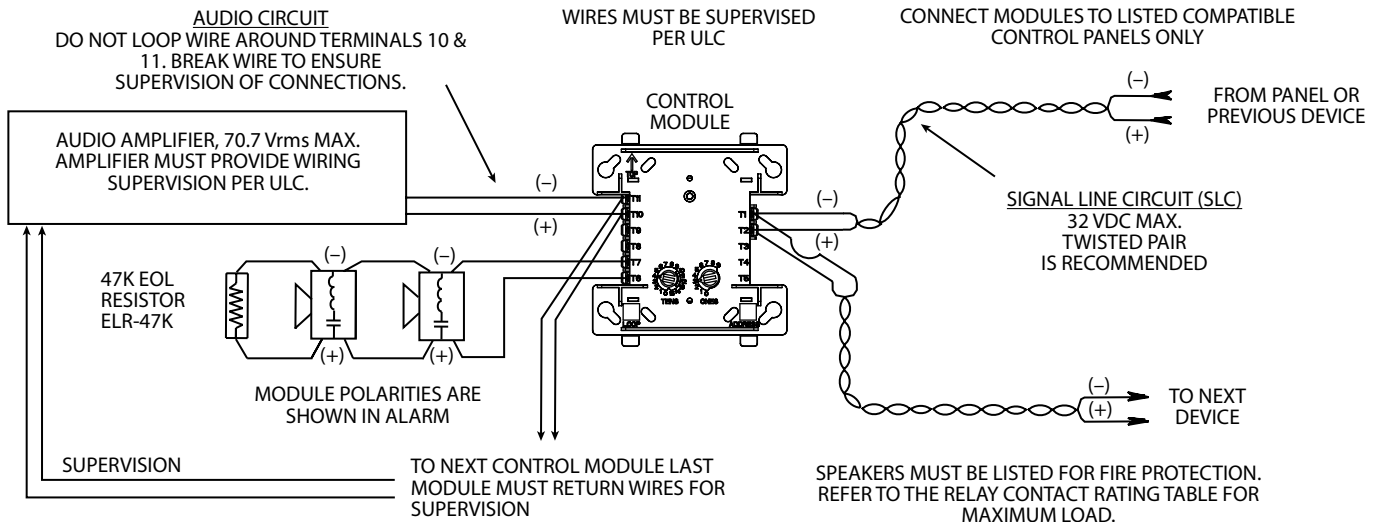

*NOTE: ANY FAULT IN THE POWER SUPPLY IS LIMITED TO THAT ZONE AND DOES NOT RESULT IN A FAULT IN A SEPARATE ZONE.

C0915-03

FIGURE 6. TYPICAL FAULT TOLERANT WIRING FOR SPEAKER SUPERVISION AND SWITCHING, NFPA STYLE Z:

AUDIO CIRCUIT WIRING MUST BE TWISTED PAIR AS A MINIMUM. SEE PANEL INSTALLATION MANUAL FOR DETAILED INFORMATION.

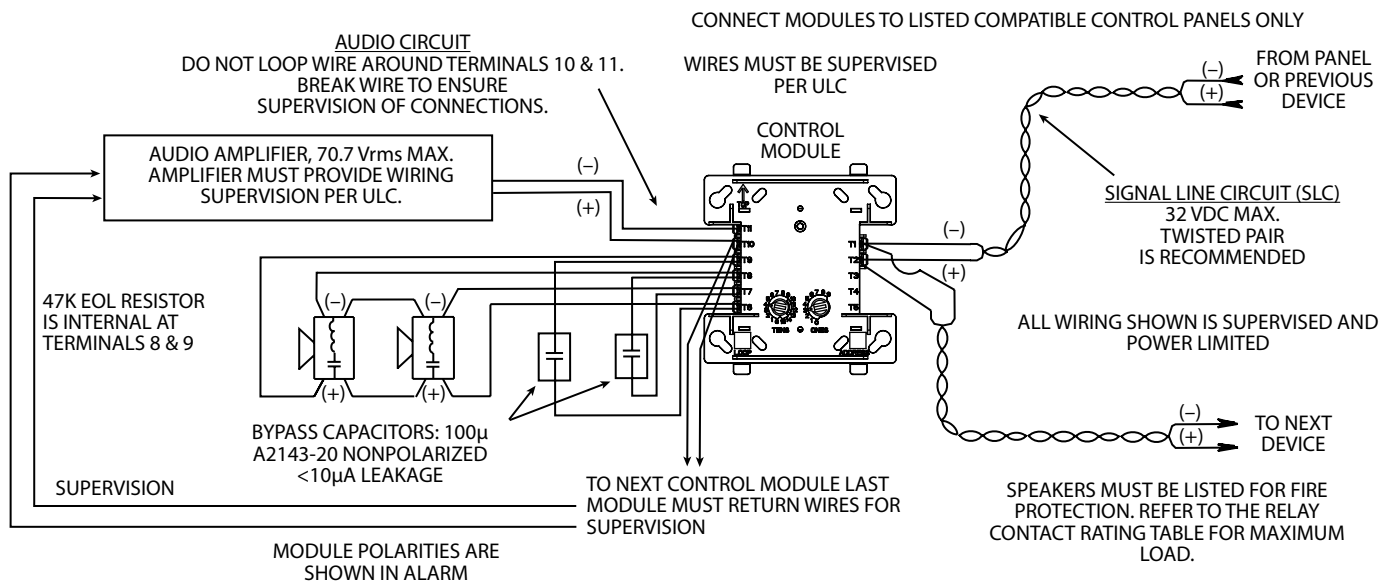

*NOTE: ANY FAULT IN THE POWER SUPPLY IS LIMITED TO THAT ZONE AND DOES NOT RESULT IN A FAULT IN A SEPARATE ZONE.

C0916-03



All relay switch contacts are shipped in the standby state (open) state, but may have transferred to the activated (closed) state during shipping. To ensure that the switch contacts are in their correct state, modules must be made to communicate with the panel before connecting circuits controlled by the module.