

## MIX-M500RAPA Relay Control Module

### SPECIFICATIONS

Normal Operating Voltage:	15 to 32 VDC
Maximum Alarm Current:	6.5mA (LED on)
Average Operating Current:	300 µA, 1 communication every 5 seconds
EOL Resistance:	Not used
Temperature Range:	32°F to 120°F (0°C to 49°C)
Humidity:	10% to 93% Non-condensing
Dimensions:	4 1/2" H x 4" W x 1 1/4" D (Mounts to a 4" square by 2 1/8" deep box.)
Accessories:	SMB500 Electrical Box; CB500 Barrier

### BEFORE INSTALLING

This information is included as a quick reference installation guide. Refer to the control panel installation manual for detailed system information. If the modules will be installed in an existing operational system, inform the operator and local authority that the system will be temporarily out of service. Disconnect power to the control panel before installing the modules.

NOTICE: This manual should be left with the owner/user of this equipment.

### GENERAL DESCRIPTION

The MIX-M500RAPA Relay Control Module is intended for use in intelligent, two-wire systems, where the individual address of each module is selected using the built-in rotary decade switches. It allows a compatible control panel to switch discrete contacts by code command. The relay contains two isolated sets of Form-C contacts, which operate as a DPDT switch and are rated in accordance with the table in the manual. Circuit connections to the relay contacts are not supervised by the module. The module also has a panel controlled LED indicator.

### COMPATIBILITY REQUIREMENTS

To ensure proper operation, these modules shall be connected to listed compatible system control panels only.

### MOUNTING

The MIX-M500RAPA mounts directly to 4" square electrical boxes (see Figure 2A). The box must have a minimum depth of 2 1/8". Surface mounted electrical boxes (SMB500) are available from Mircom.

### WIRING

NOTE: All wiring must conform to applicable local codes, ordinances, and regulations. When using control modules in nonpower limited applications, the Mircom CB500 Module Barrier must be used to meet UL requirements for the separation of power-limited and nonpower-limited terminals and wiring. The barrier must be inserted into a 4"x4"x2 1/8" junction box, and the control module must be placed into the barrier and attached to the junction box (Figure 2A). The power-limited wiring must be placed into the isolated quadrant of the module barrier (Figure 2B).

1. Install module wiring in accordance with the job drawings and appropriate wiring diagrams.
2. Set the address on the module per job drawings.
3. Secure module to electrical box (supplied by installer), as shown in Figure 2A.

FIGURE 1. CONTROLS AND INDICATORS:

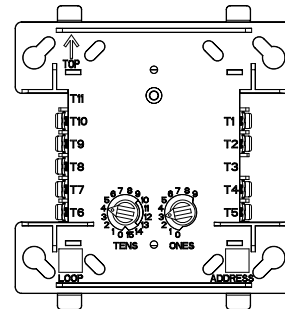

C0925-00

FIGURE 2A. MODULE MOUNTING WITH BARRIER:

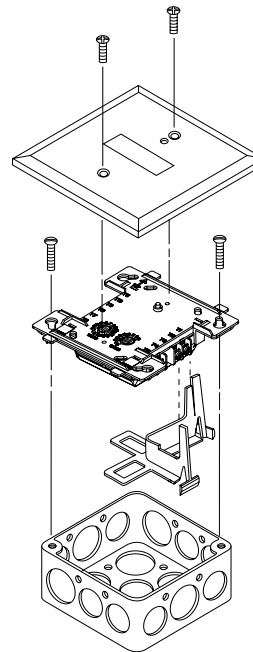
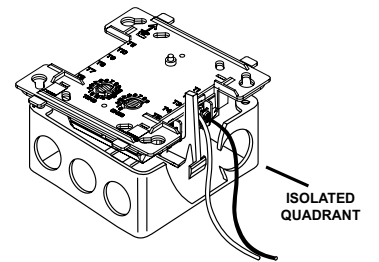

FIGURE 2B:



C0927-00

C0926-00

**RELAY CONTACT RATINGS:**

CURRENT RATING	MAXIMUM VOLTAGE	LOAD DESCRIPTION	APPLICATION
3 A	30 VDC	Resistive	Non-coded
2 A	30 VDC	Resistive	Coded
0.9 A	125 VDC	Resistive	Non-coded
0.46 A	30 VDC	(L/R=20ms)	Non-coded
0.3 A	125 VAC	(PF=0.35)	Non-coded
0.5 A	125 VAC	(PF= 0.75)	Non-coded
0.7 A	70.7 VAC	(PF=0.35)	Non-coded
2 A	25 VAC	(PF=0.35)	Non-coded



All relay switch contacts are shipped in the standby (open) state, but may have transferred to the activated (closed) state during shipping. To ensure that the switch contacts are in their correct state, modules must be made to communicate with the panel before connecting circuits controlled by the module.

**FIGURE 3. RELAY MODULE WIRING DIAGRAM:**

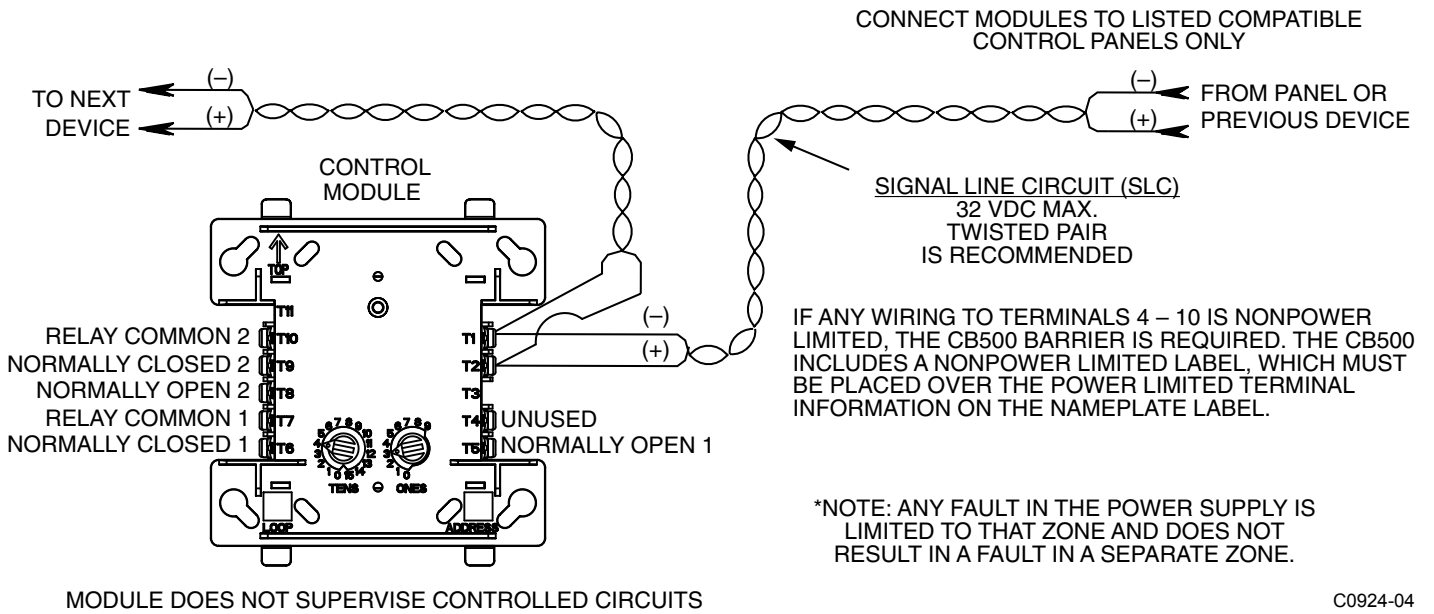

C0924-04