

Mechanical Installation for the FX-350, FA-300 and FR-320 Series Backboxes and Chassis

All the FX-350, FA-300 Series Fire Alarm Panels including the FR-320 Series have a new chassis. See the following diagrams; Figure 1 for the small panel versions of all the series and Figure 2 for the larger panel version of the FX-350 and FA-300 series.

Figure 1: Backbox and Trim Ring Dimensions for Models FA-300-3DR/ -3DDR, FA-300-6DDR, FX-350-60-DR and FR-320-R/ -W, FR-320-DR/ -DW

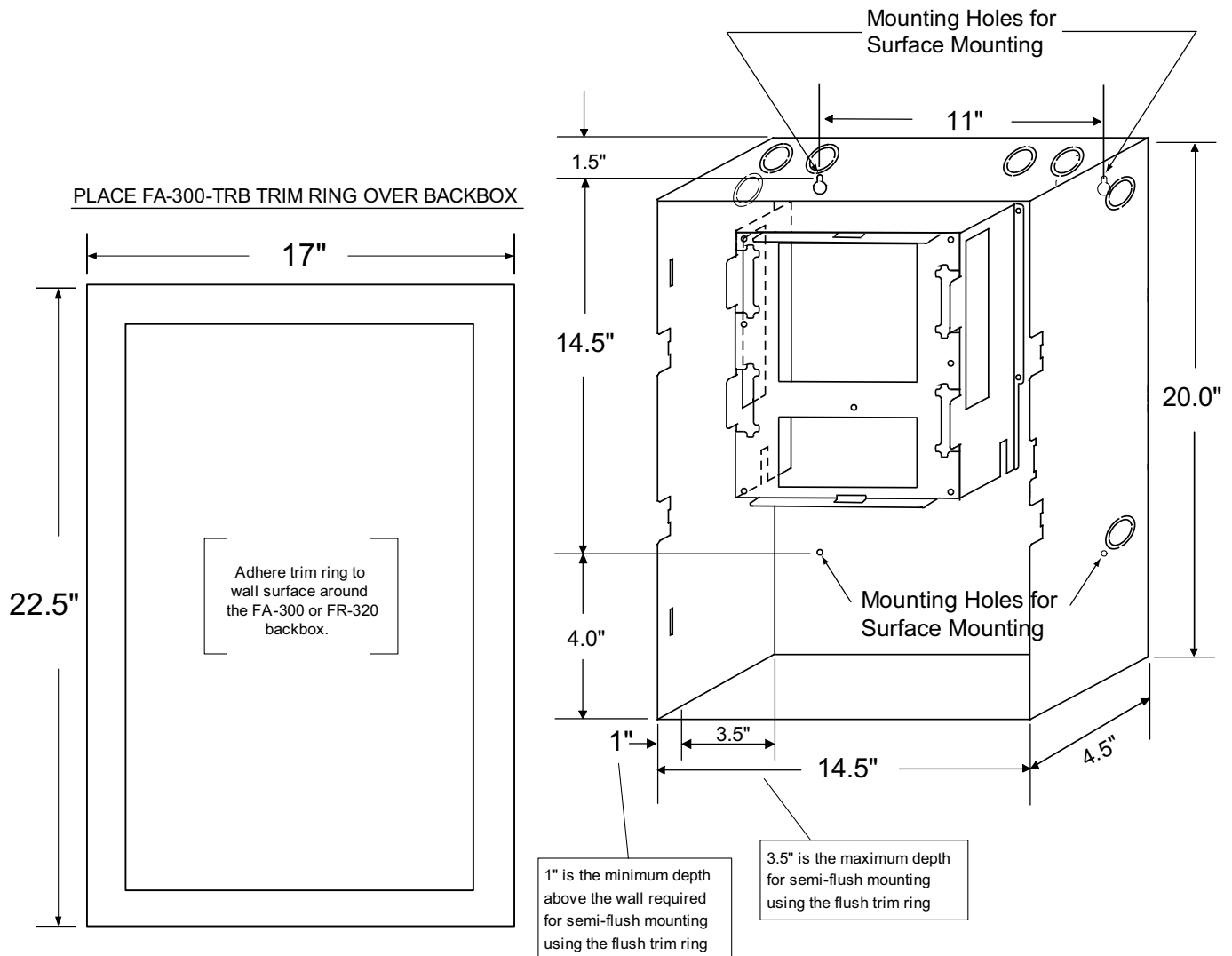
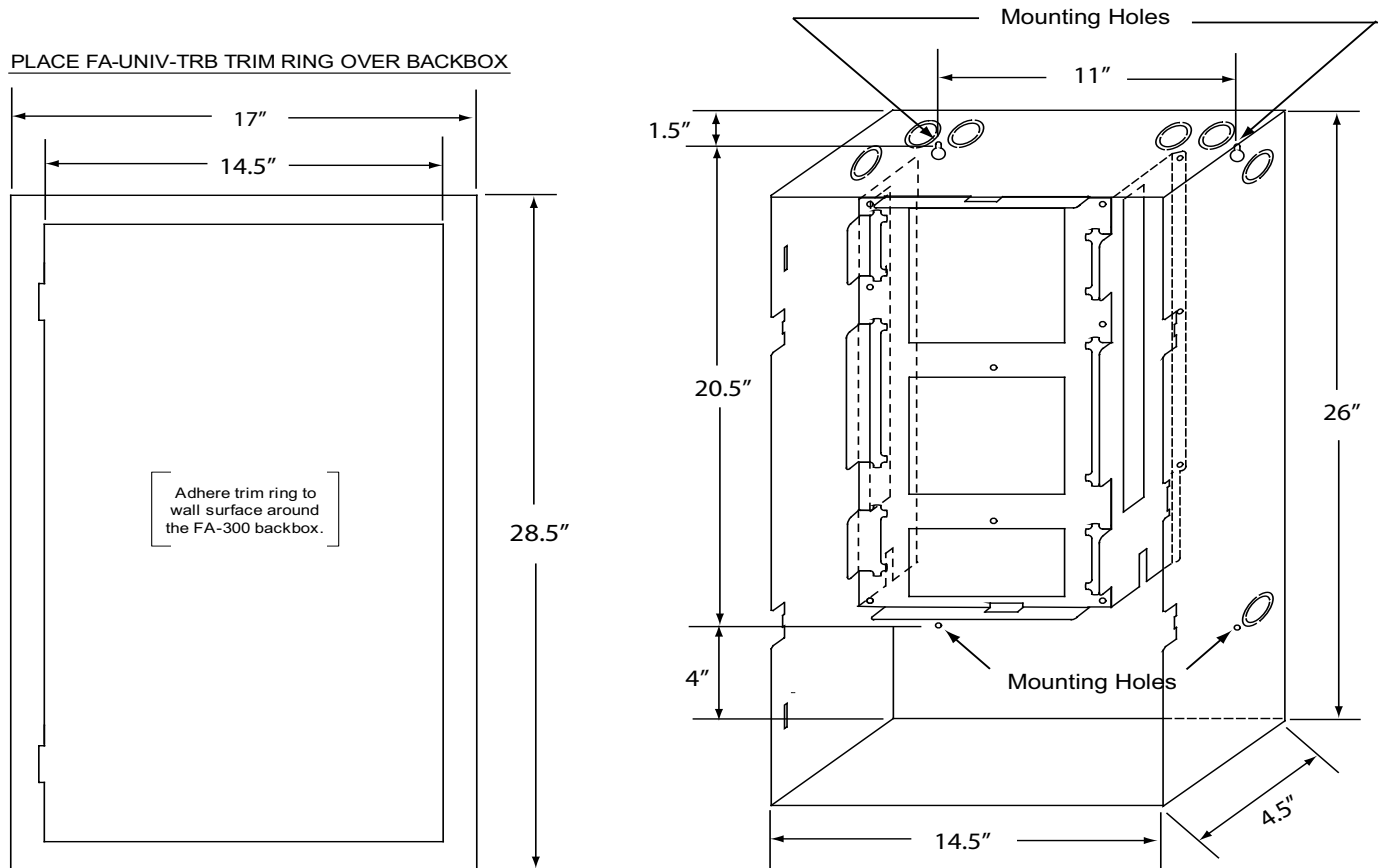

Figure 2: Backbox and Trim Ring Dimensions for Models FX-351-LW/ -LDW/ -LDR, FX-353-LW/ -LDR, FA-301-8LR/ -8LW/ -8LDR/ W and FA-301-12LR/ -12LW, FA-301-12LDR/ -12LDW, FA-301-12DDR



Mounting the Boards to the Chassis

The main board is mounted to the chassis and is shipped out this way. All adder modules are mounted in the same manner as explained in the respective fire alarm manual.

Figure 3: Cross-Section of Flush Mounted Backbox

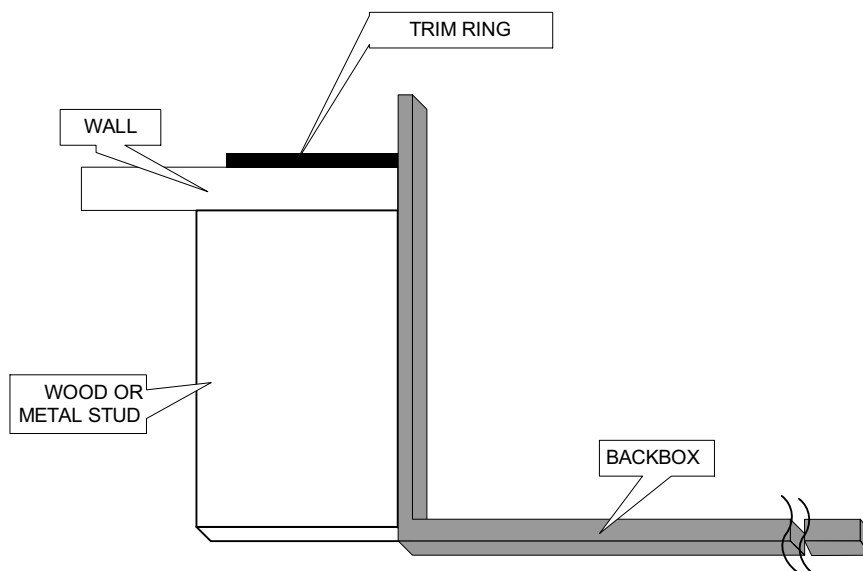

Wiring

All wiring is as explained in the respective fire alarm panel manual.