



MGCTM

ALCN-4792MISO and ALCN-792D Quad Loop Adder Motherboard and Daughter Board Installation Instructions

The ALCN-4792MISO Quad Loop Adder module provides two addressable loops plus an additional two loops as part of the daughter board ALCN-792D which is mounted over the ALCN-4792MISO. The Quad Loop Adder module may be mounted over the main chassis of the Network Fire Alarm Panel or on any chassis that supports adder boards. This module is mounted using four #6 screws and (if necessary) four 1 1/2" spacers.

Power	The power is supplied to the board via cable from the main chassis board or from the previous loop controller module into the P1 POWER IN connector. Connect the P2 POWER OUT connector to the next loop controller module or other adder module. One power cable is supplied with this module.
RS-485:	The RS-485 cable comes attached at P4 and is either connected to P3 of the main fire alarm controller module or connected from the previous loop controller module or other adder board. If the next loop controller module is used, connect the RS-485 out at P3 on ALCN-4792MISO to the next loop controller module; if it is not used, leave without connection.
DIP Switches:	Use the DIP switches to set the binary address of the board. SW1-1 is the lowest significant digit and ON is active. For example, an address of two would be created by turning SW1-1 OFF, SW1-2 ON and DIP switches SW1-3 to SW1-8 OFF. Refer to DIP switch settings in table below.
Loop 1:	This is the addressable loop for all initiating devices. Wire the loop as shown in the Network Fire Alarm Manual.
Loop 2:	This is the addressable loop for all initiating devices. Wire the loop as shown in the Network Fire Alarm Manual.
Shield:	If the loops are shielded, connect the shields to the terminals marked COM(-). To prevent the board reporting a ground fault, do not connect shields on SLC lines to earth ground. Note: Unshielded wiring is preferred.
Jumpers:	ALCN-4792MISO: <ul style="list-style-type: none"> • JW1: Factory use only. Leave open. • JW2: Factory use only. Leave closed. • JW3: 3 pin jumper. Normally set to 1-2, can be set to 2-3 to prevent noise from CLIP System Sensor sounder bases on Loop 1. Pin 1 is marked with a dot. • JW4: 3 pin jumper. Normally set to 1-2, can be set to 2-3 to prevent noise from CLIP System Sensor sounder bases on Loop 2. Pin 1 is marked with a dot. • JW6: Factory use only. Leave closed. ALCN-792D: <ul style="list-style-type: none"> • See page 3.
JTAG Port:	This connection is for factory use only.
USB Port:	This connection is for factory use only.

ALCN-4792MISO DIP Switch Setting

Set the DIP switches on SW1 starting at address 1 for the first ALCN-4792MISO adder and consecutively up to seven for the next six ALCN-4792MISO modules. Refer to the Network Fire Alarm Manual for the maximum quad ALCN-4792MISO adder modules allowed per node.

ALCN-4792MISO	ADDR	SW1-1	SW1-2	SW1-3	SW1-4	SW1-5	SW1-6	SW1-7	SW1-8
	1	ON	OFF	OFF	OFF	OFF	OFF	OFF	OFF
	2	OFF	ON	OFF	OFF	OFF	OFF	OFF	OFF
	3	ON	ON	OFF	OFF	OFF	OFF	OFF	OFF
	4	OFF	OFF	ON	OFF	OFF	OFF	OFF	OFF
Refer to Network Fire Alarm Manual as to whether addresses 5, 6 and 7 are available									
	5	ON	OFF	ON	OFF	OFF	OFF	OFF	OFF
	6	OFF	ON	ON	OFF	OFF	OFF	OFF	OFF
	7	ON	ON	ON	OFF	OFF	OFF	OFF	OFF

Put in "ON" position for firmware restore to defaults during power up. At all other times put in "OFF" state.

ALCN-4792MISO Wiring

The location of Loop 1 and 2 terminals on ALCN-4792MISO are shown in Figure 1 below. Also shown are the power in and out cable locations, DIP switch location, and jumper locations.

Figure 1: ALCN-4792MISO Isolated Quad Loop Adder Module

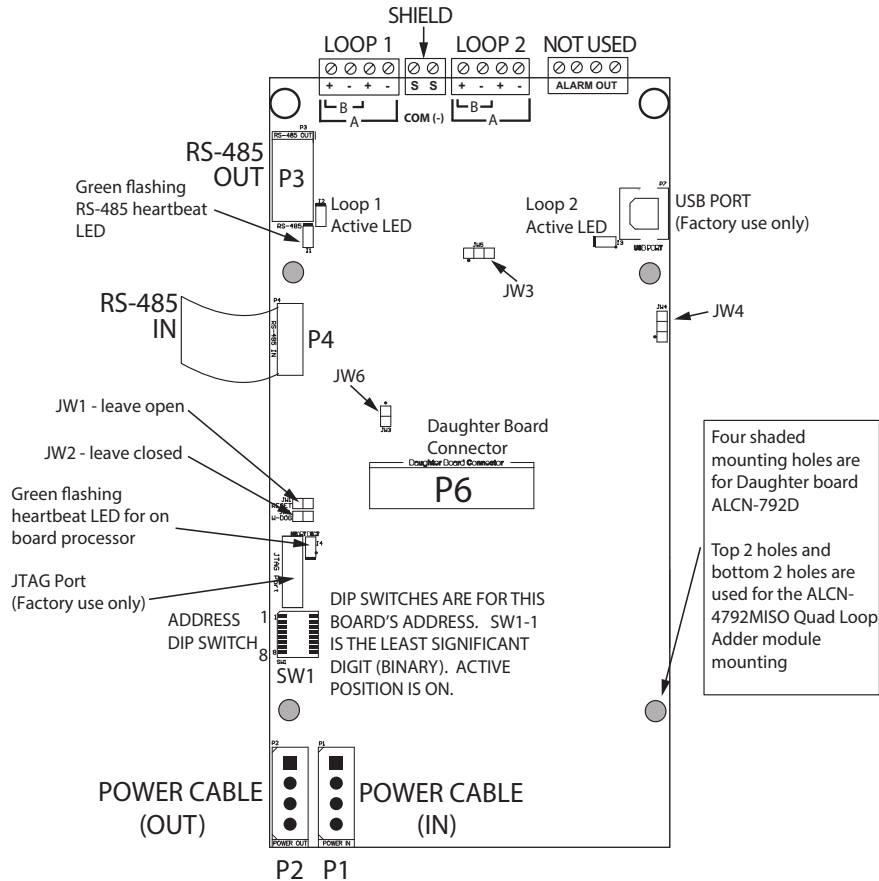

- All circuits are power limited and must use type FPL, FPLR, or FPLP power limited cable.
- Loop wiring: maximum loop resistance is 40 ohms total. These lines are power-limited and fully supervised.
- Refer to wiring instructions in the Network Fire Alarm Manual.

ALCN-792D Daughter Board Installation

The location of Loop 1 and 2 terminals on ALCN-792D are shown in Figure 2 below. Also shown are the jumper locations.

The ALCN-792D Daughter Board provides another two addressable loops when connected to the ALCN-4792MISO Quad Loop Adder Board. This daughter board is mounted over the ALCN-4792MISO using the four screws and spacers provided. Wire the two addressable loops on the ALCN-792D Daughter Board in the same manner as the ALCN-4792MISO addressable loops are wired.

If the loops have shielding, connect the shields to the terminals marked COM(-). To prevent the board reporting a ground fault, do not connect shields on SLC lines to earth ground.

Note: Unshielded wiring is preferred.

Figure 2: ALCN-792D Daughter Board

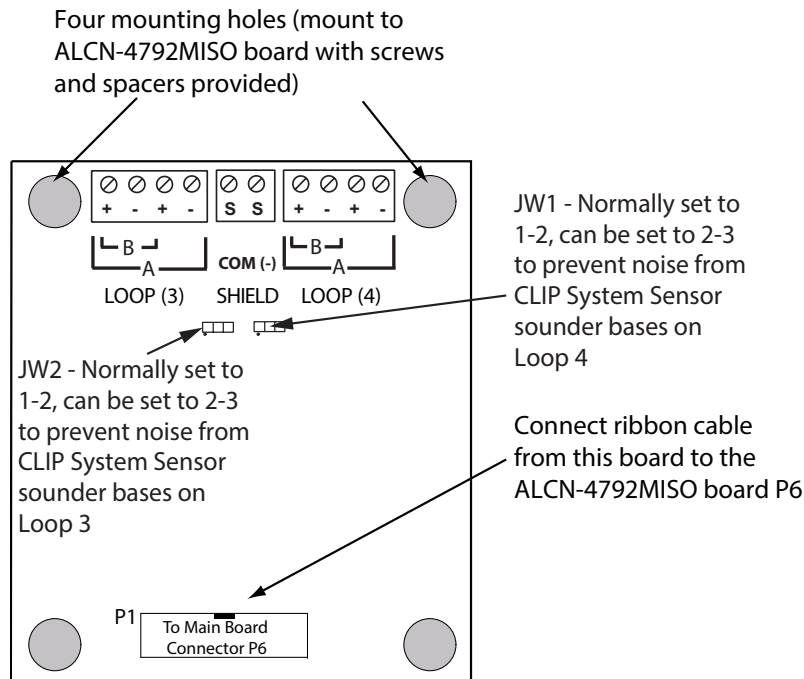

Notes:

- All circuits are power limited and must use type FPL, FPLR, or FPLP power limited cable.
- Loop wiring: maximum loop resistance is 40 ohms total. These lines are power-limited and fully supervised.
- For complete wiring instructions, refer to the Network Fire Alarm Manual.