

FX-401

Addressable Fire Alarm Control Panel



Table of Contents

1.0	Industry Canada and FCC Notice	7
1.1	Notice for all FX-400 Series Built-In UDACTs Sold in Canada	7
1.2	Industry Canada Notice	7
1.3	Notice for all FX-400 Series Built-in UDACTs Sold in the U.S.A.	7
1.4	FCC Notice	8
2.0	Introduction	9
2.1	The FX-401 Addressable Fire Alarm Control Panel	9
2.2	General Notes	10
3.0	FX-401 Overview	11
3.1	FX-401 Addressable Fire Alarm Control Panel Model	11
3.2	FX-401 System Components	12
4.0	Installation	17
4.1	UB-1024DS Mechanical Installation	17
4.2	Installation Tips	18
4.3	Connections and Jumpers	19
4.4	Installing Adder Modules	21
4.5	Annunciators	28
4.6	SRM-312R/SRM-312W Smart Relay Module	28
4.7	RTI-1 Remote Trouble Indicator	28
5.0	Operation	29
5.1	Addressable/Analog Devices	29
5.2	Configurable Input Types	31
5.3	Output Types	36
5.4	NAC Circuit Operation	37
5.5	Single Stage Operation	38
5.6	Two-Stage Operation	39
5.7	Evacuation Codes	40
5.8	Positive Alarm Sequence	40
5.9	Remote Annunciator Operation	42
5.10	Dialer Operation	43
5.11	Using the Operation Menu from the Control Panel	44

6.0	Indication and Controls	61
6.1	Indication and Controls	61
6.2	LCD Display	61
6.3	Common LED Indicators and Control Buttons	63
7.0	Wiring	67
7.1	Wiring Tables	67
7.2	Wire Routing	69
7.3	Addressable Loop (Signaling Line Circuit) Wiring	70
7.4	NAC Circuit Wiring	71
7.5	TS1 SPECIAL APPLICATION Power Source	74
7.6	Module and Devices Wiring	75
7.7	Power Supply Wiring	80
7.8	Placement of Ferrites for FCC Standard	83
7.9	System Checkout	84
7.10	Troubleshooting	84
	Appendix A: Compatible Receivers	85
	Appendix B: Manual Panel Configuration	86
	Appendix C: Reporting	102
	Appendix D: Specifications	105
	Appendix E: Battery Calculations	107
	Warranty and Warning Information	109

List of Figures

Figure 1	FX-401 with DOX-1024DSR	11
Figure 2	UB-1024DS Backbox Installation Instructions and Dimensions	17
Figure 3	Connector and Jumper Locations on Main Board	19
Figure 4	Jumper on Back of Display	21
Figure 5	Main Board with all Modules Installed	22
Figure 6	Installing the PR-300 Polarity Reversal and City Tie Module	23
Figure 7	Installing the ALC-480 Dual Loop Adder	24
Figure 8	IPS-2424DS Programmable Input Switches Module Front Chassis View	25
Figure 9	IPS-2424DS Cable Connections	26
Figure 10	IPS-4848DS Programmable Input Switches Module Front Chassis View	27
Figure 11	IPS-4848DS Cable Connections	27
Figure 12	MGC-400 Configurator Date and Time Settings	30
Figure 13	Enabling the Positive Alarm Sequence	41
Figure 14	Operation Menu	45
Figure 15	LED Indicators and Control Buttons	61
Figure 16	Numeric Keypad	62
Figure 17	Wire Routing	69
Figure 18	Addressable Loop Wiring - Class B (DCLB)	70
Figure 19	Addressable Loop Wiring - Class A (DCLA)	70
Figure 20	Addressable Loop Wiring - Class X (DCLC)	71
Figure 21	NAC Circuit – Class B Wiring	71
Figure 22	NAC Circuit – Class A Wiring	72
Figure 23	RTI-1 Common Remote Trouble Indicator Wiring	73
Figure 24	TS1 SPECIAL APPLICATION Power Source Wiring	74
Figure 25	Wiring the Dialer	75
Figure 26	Connecting an FACP to a 3G4010 Interface Device in Canada	76
Figure 27	Connecting an FACP to a 3G4010CF Interface Device outside Canada	77
Figure 28	Connecting an FACP to a SLE-LTEV or SLE-LTEA Interface Device outside Canada ..	78
Figure 29	Wiring the PR-300 Polarity Reversal and City Tie Module	79
Figure 30	Main Power Supply Wiring and Connections	81
Figure 31	Supervision of Auxiliary Supplies	82

List of Tables

Table 1	FX-401 System Components	12
Table 2	Main Board Connectors and Jumpers	20
Table 3	Core Board Connectors and Jumpers	21
Table 4	PR-300 Polarity Reversal and City Tie Module Connectors and Jumpers	23
Table 5	ALC-480 Dual Loop Adder Connector	24
Table 6	Settings Permitted in UL864	29
Table 7	Settings Permitted in CAN/ULC-S527and CAN/ULC-S559	29
Table 8	Configurable Input Types	31
Table 9	Configurable Output Types	36
Table 10	Annunciator Address DIP Switch Settings	42
Table 11	List Bypass Special Characters	56
Table 12	Numeric Keypad and Cursor Buttons	62
Table 13	LED Indicators and Control Buttons	63
Table 14	MGC Devices Addressable Loop Wiring Table	67
Table 15	NAC and Auxiliary Power Circuits Wiring Table	68
Table 16	Conventional Zone Module Input Circuit Wiring Table	68
Table 17	Power Supply Electrical Ratings	80
Table 18	Compatible DACR Receivers	85
Table 19	Contact-ID Event Codes	102
Table 20	SIA-DCS Event Codes	103
Table 21	FX-401 Specifications	105
Table 22	FX-401 Modules and Annunciator Specifications	106
Table 23	Recommended Batteries	108

1.0 Industry Canada and FCC Notice

1.1 Notice for all FX-400 Series Built-In UDACTs Sold in Canada

Mircom's FX-400 SERIES BUILT-IN UDACT Communicator described in this manual is listed by Underwriters Laboratories Canada (ULC) for use in slave application under Standard ULC-S527 (Standard for Control Units for Fire Alarm Systems) and ULC-S559 (Equipment for Fire Signal Receiving Centres and Systems). These Communicators should be installed in accordance with this manual; the Canadian / Provincial / Local Electrical Code; and/or the local Authority Having Jurisdiction (AHJ).

1.2 Industry Canada Notice

Repairs to certified equipment should be made by an authorized Canadian maintenance facility designated by the supplier. Any repairs or alteration made by the user to this equipment, or equipment malfunctions, may give the telecommunications company cause to request the user to disconnect the equipment. Users should ensure for their own protection that the Earth Ground connections of the power utility, telephone lines and internal metallic water pipe system, if present, are connected together. This is necessary both for proper operation and for protection.



Attention: Users should not attempt to make such connections themselves, but should contact the appropriate electric inspection authority, or electrician, as appropriate.

1.3 Notice for all FX-400 Series Built-in UDACTs Sold in the U.S.A.



Notes: The Ringer Equivalence Number (REN) assigned to each terminal device provides an indication of the maximum number of terminals allowed to be connected to a telephone interface. The termination on an interface may consist of any combination of devices subject only to the requirement that the sum of the Ringer Equivalence Numbers of all the devices does not exceed 5.

The Label Identification Number for this product is US:1M8AL01BFX3500. The 01B represents the REN without a decimal point (for example, 01B is a REN of 0.1B).

Mircom's FX-400 SERIES BUILT-IN UDACT Digital Communicator described in this manual is listed by Underwriters Laboratories Inc. (ULI) for use in slave application in conjunction with a Listed Fire Alarm Control Panel under Standard 864 (Control Units for Fire Protective Signalling Systems). These Communicators comply with the National Fire Protection Association (NFPA) performance requirements for UDACTs and should be installed in accordance with NFPA 72 (Supervising Station Fire Alarm System). These Communicators should be installed in accordance with this manual; the National Electrical Code (NFPA 70); and/or the local Authority Having Jurisdiction (AHJ).

1.4 FCC Notice

This equipment complies with Part 68 of the FCC rules and the requirements adopted by the ACTA. On the telco transformer of this equipment is a label that contains, among other information, a product identifier in the format US:1M8AL01BFX3500. If requested, this number must be provided to the telephone company. This equipment is capable of seizing the line. This capability is provided in the hardware.

Type of Service

The Communicator is designed to be used on standard device telephone lines. It connects to the telephone line by means of a standard jack called the USOC RJ-11C (or USOC FJ45S). Connection to telephone company provided coin service (central office implemented systems) is prohibited. Connection to party lines service is subject to state tariffs.

Telephone Company Procedures

The goal of the telephone company is to provide you with the best service it can. In order to do this, it may occasionally be necessary for them to make changes in their equipment, operations or procedures. If these changes might affect your service or the operation of your equipment, the telephone company will give you notice, in writing, to allow you to make any changes necessary to maintain uninterrupted service. In certain circumstances, it may be necessary for the telephone company to request information from you concerning the equipment which you have connected to your telephone line. Upon request of the telephone company, provide the FCC registration number and the ringer equivalence number (REN); both of these items are listed on the equipment label. The sum of all of the RENs on your telephone lines should be less than five in order to assure proper service from the telephone company. In some cases, a sum of five may not be usable on a given line.

If Problems Arise

If any of your telephone equipment is not operating properly, you should immediately remove it from your telephone line, as it may cause harm to the telephone network. If the telephone company notes a problem, they may temporarily discontinue service. When practical, they will notify you in advance of this disconnection. If advance notice is not feasible, you will be notified as soon as possible. When you are notified, you will be given the opportunity to correct the problem and informed of your right to file a complaint with the FCC. Contact your telephone company if you have any questions about your phone line. In the event repairs are ever needed on the Communicator, they should be performed by Mircom Technologies Ltd. or an authorized representative of Mircom Technologies Ltd. For information contact Mircom Technologies Ltd. at the address and phone numbers shown on the back page of this document.

2.0 Introduction

This document provides information for the successful installation and operation of the FX-401 addressable fire alarm control panel (FACP).

2.1 The FX-401 Addressable Fire Alarm Control Panel

Mircom's FX-401 addressable fire alarm control panel provides the following:

- MGC Protocol with up to three addressable (SLC) loops with a maximum of 720 MGC devices (MIX-4000 series), 240 per loop.
- Compatible with MGC devices (MIX-4000 series).
- Compatible with conventional detectors using MGC MIX-4042 analog interface (conventional zone) module; refer to document LT-1023 for compatible conventional detectors.
- Four power limited class B or class A NAC circuits rated at 1.5A each, 6.0A total.
- NAC circuits may be configured as silenceable signal, non-silenceable signal, silenceable strobes, non-silenceable strobes, or relay output. The audible signal may be steady, temporal code, California code, or march time.
- Supports sync strobe protocols from major manufacturers.
- Supports MGC 400 series NAC devices.
- Capable of reporting carbon monoxide events in accordance with the UL 864 tenth edition and ULC S527 fourth edition standards
- Two-stage, alarm verification, and positive alarm sequence operations.
- Configurable signal silence inhibit, auto signal silence, two-stage operation, and one-man walk test.
- Subsequent alarm, supervisory, monitor and trouble operation.
- Relay contacts for common alarm, common supervisory and common trouble all non-disconnectable and auxiliary alarm relay (disconnectable).
- Built-in dialer.

2.1.1 Optional Items

- Supports up to 2 RAX-1048TZDS display adder modules.
- Semi-flush or surface mountable enclosures for retrofits and new installations.



Note: Installation of the FX-401 Addressable Fire Alarm Control panel should be in accordance with Canadian Electrical Code Part 1, ULC-S524 installation of Fire Alarm System; or National Electrical Code NFPA 70 and NFPA 72. Final acceptance subject to the Local Authority Having Jurisdiction (AHJ).

2.2 General Notes

Circuits

Circuit refers to a physical electrical interface for the analog loop, indicating signals or relays, and common alarm, supervisory, and trouble relay outputs.

Zone/Group

Zone or **Group** is a logical concept for a fire alarm protected area, and will consist of at least one circuit. The FX-401 uses zones to facilitate annunciation of multiple input and output points on the RAX-1048TZDS (up to 96 points) and to facilitate the indication of bypass points.

Display Points

The FX-401 LCD display annunciates the status of the system and connected devices. There are up to two (2) RAX-1048TZDS display points that may be configured to assign LEDs to groups of inputs or outputs. There are two LEDs for every display point; one single color (yellow) and one dual color (red/yellow).

Wiring Styles

The addressable (SLC) loops can be configured system-wide as class B (DCLB) or class A (DCLA). With the addition of isolators, a class A (DCLA) loop will become a class X (DCLC).

3.0 FX-401 Overview

This chapter lists all the possible components of an FX-401 addressable fire alarm control system.

3.1 FX-401 Addressable Fire Alarm Control Panel Model

The FX-401 addressable fire alarm control panel has the following features:

- Main board, power supply and backbox.
- Addressable fire alarm control panel.
- MAM-3500 main display with 4 x 20 LCD display.
- Class A (DCLA), class X (DCLC), or class B (DCLB) SLC analog loop(s).
- Four power limited class B, class A NAC circuits (max 1.5 amps each - 6.0 amps total).
- MGC Protocol with up to three addressable (SLC) loops with a maximum of 720 MGC devices (MIX-4000 series), 240 per loop.
- Dedicated common alarm, supervisory, trouble, and auxiliary alarm relays.
- Additional RAX-1048TZDS display adder module can be added to provide 48 annunciation points per adder. Two modules required for 96 annunciation points.
- Additional outputs include connections for a RTI-1 remote trouble indicator, PR-300 reverse polarity module, an RS-485 bus for connection of up to seven RAX-LCD-LITE, RAM-3500-LCDs, SRM-312Rs or SRM-312Ws and RA-1000 series annunciators.
- Auxiliary power is available in the form of 24V FWR unfiltered and unsupervised, 24VDC filtered and regulated, and resettable auxiliary power supply.



Figure 1 FX-401 with DOX-1024DSR

3.2 FX-401 System Components

The following table describes the components of the FX-401 Addressable Fire Alarm Control System.

Table 1 FX-401 System Components



	Model	Description
	<p>FX-401</p>	<p>Model FX-401, black backbox, red door enclosure comes complete with main board, power supply, transformer and main display.</p>
	<p>MAM-3500</p>	<p>Main display</p>
	<p>RAM-3500-LCD</p>	<p>Remote annunciator with 4-line LCD display.</p>
	<p>DOX-1024DS</p>	<p>White enclosure door</p>
	<p>DOX-1024DSR</p>	<p>Red enclosure door</p>

Table 1 FX-401 System Components (Continued)

	Model	Description
	ALC-480	480 point dual loop adder
	PR-300	Polarity reversal and city tie module.
	PCS-100	Power supply interface board use for powering SLE-LTEV, SLE-LTEA, 3G4010CF or 3G4010 Universal Wireless Alarm Communicator.
	SRM-312W	Smart relay module with white enclosure. Can support up to 12 relays.
	SRM-312R	Smart relay module with red enclosure. Can support up to 12 relays.
	IPS-2424DS	Programmable input switches module with 24 switches.
	IPS-4848DS	Programmable input switches module with 48 switches.

Table 1 FX-401 System Components (Continued)



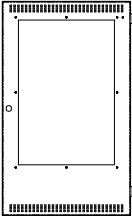
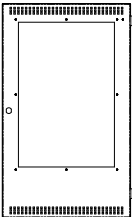

	Model	Description
	<p>RAM-1032TZDS RAM-1032TZDS-CC</p>	<p>RAM-1032TZDS main chassis remote annunciator with 16 bi-colored LEDs and 32 trouble LEDs. RAM-1032TZDS-CC is the same as the RAM-1032TZDS, except it has conformal coating and is to be used in the BB-1001WPA/BB-1001WPRA weather protected box.</p>
	<p>RAX-1048TZDS RAX-1048TZDS-CC</p>	<p>RAX-1048TZDS adder annunciator chassis with 48 bi-colored LEDs and 48 trouble LEDs. RAX-1048TZDS-CC is the same as the RAX-1048TZDS, except it has conformal coating and is to be used in the BB-1002WPA/BB-1002WPRA weather protected box.</p>
	<p>MGD-32</p>	<p>Master graphic driver module.</p>
	<p>RAX-LCD-LITE</p>	<p>Remote annunciator with 4-line LCD display.</p>
	<p>AGD-048</p>	<p>Adder graphic driver module.</p>
	<p>RTI-1</p>	<p>Common remote trouble indicator, buzzer and LED.</p>

Table 1 FX-401 System Components (Continued)



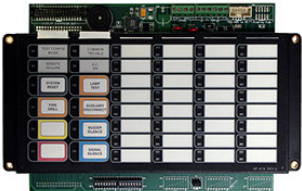

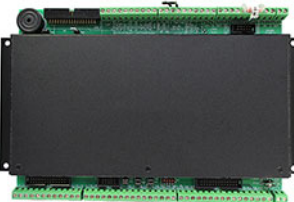
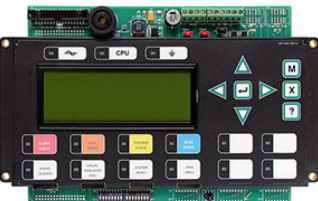
	Model	Description
	BB-1001D	White enclosure for one annunciator.
	BB-1001DR	Red enclosure for one annunciator.
	BB-1001DS	Enclosure for one annunciator with stainless steel door.
	BB-1001DB	Black enclosure for one annunciator.
	BB-1001WPA	White enclosure for one annunciator rated for outdoor environment, wet location.
	BB-1001WPRA	Red enclosure for one annunciator rated for outdoor environment, wet location.
	BB-1002D	White enclosure for two annunciators.
	BB-1002DR	Red enclosure for two annunciators.
	BB-1002DS	Enclosure for two annunciators with stainless steel door.
	BB-1002DB	Black enclosure for two annunciators.
	BB-1002WPA	White enclosure for two annunciators rated for outdoor environment, wet location.
	BB-1002WPRA	Red enclosure for two annunciators rated for outdoor environment, wet location.
	BB-1003D	White enclosure for three annunciators.
	BB-1003DR	Red enclosure for three annunciators.
	BB-1003DS	Enclosure for three annunciators with stainless steel door.
	BB-1003DB	Black enclosure for three annunciators.
	BB-1008D	White enclosure for eight annunciators.
	BB-1008DR	Red enclosure for eight annunciators.
	BB-1012D	White enclosure for twelve annunciators.
	BB-1012DR	Red enclosure for twelve annunciators.

Table 1 FX-401 System Components (Continued)

	Model	Description
	MP-300	End-of-line resistor plate. 3.9 kΩ.

3.2.1 Devices

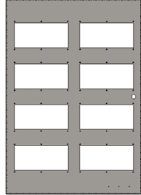
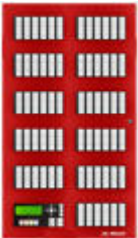
Refer to document LT-1023 for compatible devices.

4.0 Installation

This chapter describes the installation of the FX-401.

4.1 UB-1024DS Mechanical Installation

The UB-1024DS is a black backbox suitable for flush or surface mounting with a built-in trim ring. The DOX-1024DS is the front door of this backbox, which is available in white and red, DOX-1024DSR. An enclosure consists of the backbox plus the connected front door.

Dimensions of enclosure (minus built in trim ring)	14.5" x 4.2" x 26"
Distance between horizontal mounting screws	12"
Distance between vertical mounting screws	23.5"
Complete dimensions of enclosures	16.3" x 5.5" x 27.5"

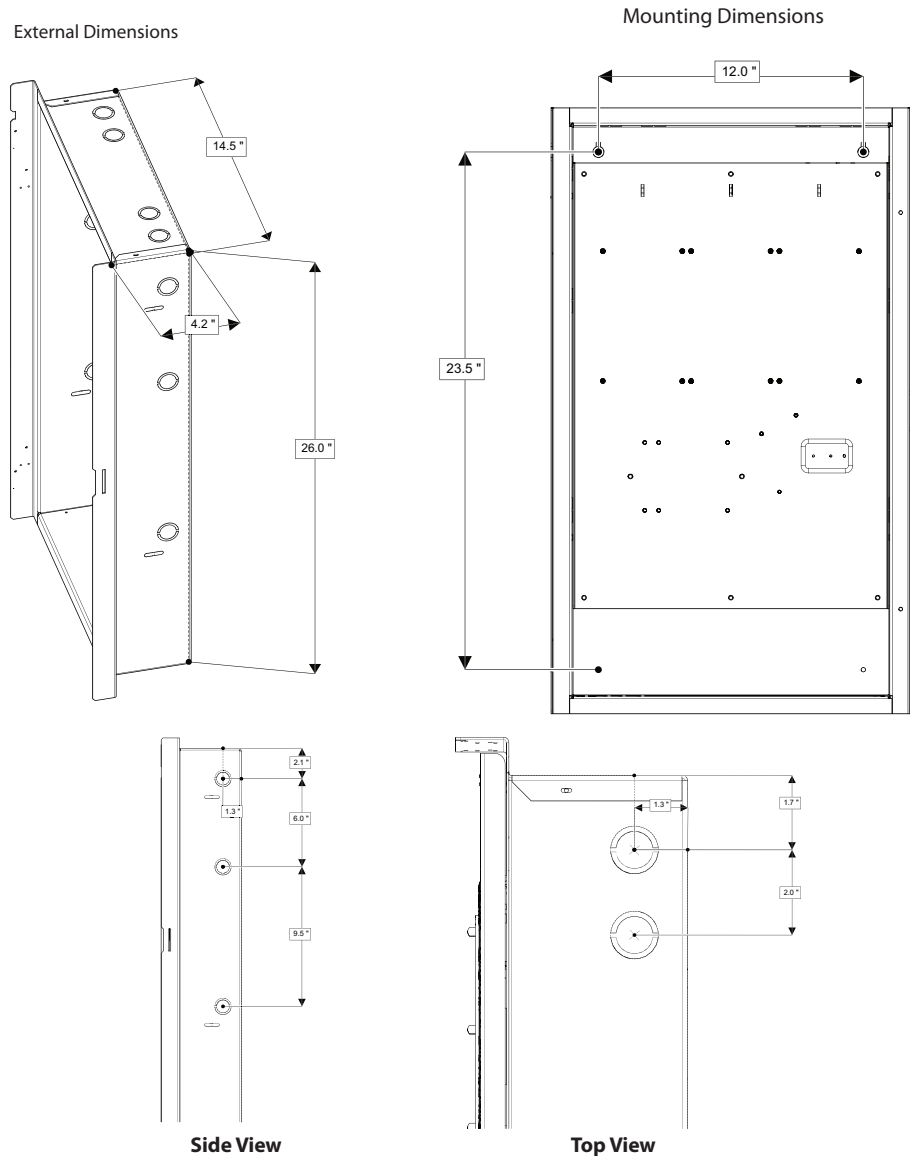

Figure 2 UB-1024DS Backbox Installation Instructions and Dimensions

4.2 Installation Tips

1. Group the incoming wires through the top of the enclosure. For easy identification and neatness use a wire tie to group wires.
2. Be sure to connect a solid earth ground (from building system ground / to a cold water pipe) to the chassis earth ground mounting lug, and to connect the earth ground wire lugs from the main chassis to the ground screw on the backbox.



Attention: DO NOT install cable through bottom of the box. This space is reserved for batteries.

4.3 Connections and Jumpers

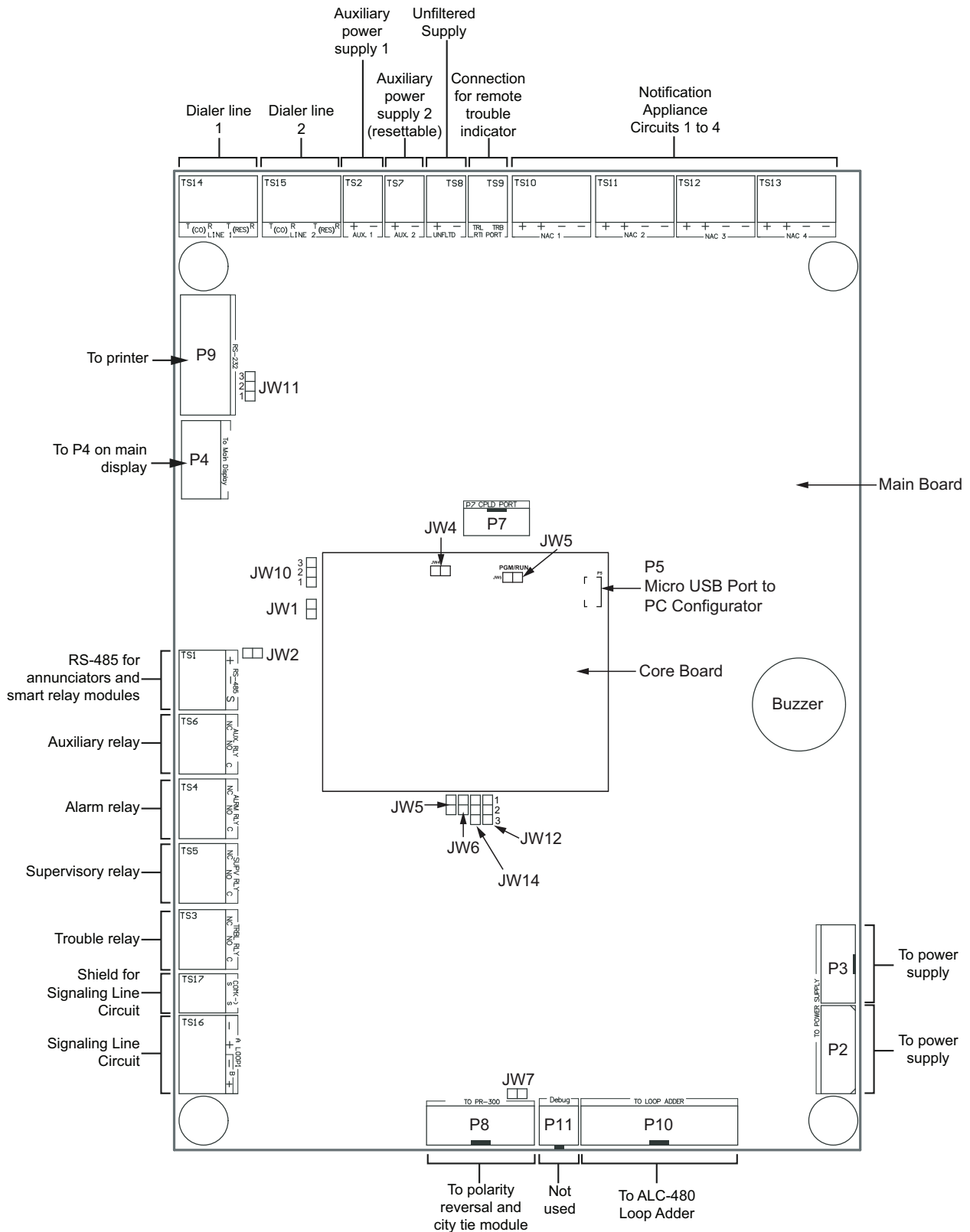

Figure 3 Connector and Jumper Locations on Main Board

Table 2 Main Board Connectors and Jumpers

Connector/ Jumper	Description
TS1	RS-485 for annunciators and SRM-312R/SRM-312W
TS2	Auxiliary power supply 1, used to power the remote annunciators and smart relay modules (section 7.7.2)
TS3	Trouble relay
TS4	Alarm relay
TS5	Supervisory relay
TS6	Auxiliary relay
TS7	Auxiliary power supply 2 (resettable) (section 7.7.2)
TS8	Unfiltered supply (section 7.7.2)
TS9	Connection for RTI-1 (section 7.4.4)
TS10-TS13	Notification appliance circuits 1 to 4 (section 7.4)
TS14	Dialer line 1 (section 7.6)
TS15	Dialer line 2 (section 7.6)
TS16	Signaling line circuit (section 7.3)
TS17	Shield for signaling line circuit (section 7.1.1)
P2	To P4 on power supply (section 7.7)
P3	To P2 on power supply (section 7.7)
P4	Ribbon cable connects to P4 on main display
P7	Not used
P8	To PR-300
P9	To printer
P10	To ALC-480 Loop Adder
P11	Not used
JW1	Must be on (closed) - allows configuration connection. The default setting is on (closed)
JW2	Must be on (closed) - annunciator end-of-line. The default setting is on (closed)
JW5	Normally off (open). Place jumper here and power down (AC and batteries) and power back to restore master passcode. After reset, remove jumper and leave open. The default setting is off (open)
JW6	Normally off (open) to BLOCK remote configuration with a modem. Place jumper here to ALLOW for remote configuration. When jumper is on (closed), panel will indicate a trouble. The default setting is off (open)
JW7	This jumper must be off (open) if a PR-300 polarity reversal and city tie module is installed. The default setting is on (closed)
JW10	Must be in the 1-2 position (bottom 2 pins) - allows PC connection through serial port
JW11	Place in the 1-2 position (bottom 2 pins) for serial port or place in the 2-3 position (top 2 pins) for Keltron dialer

Table 2 Main Board Connectors and Jumpers (Continued)

Connector/ Jumper	Description
JW12	Close pins 2 and 3 to send the debug trace to the printer. Close pins 1 and 2 to send events to the printer. The printer is supervised when the pins are in position 2 and 3. The default setting is the 1-2 position
JW14	Factory set on pins 1 and 2. Do not change

Table 3 Core Board Connectors and Jumpers

Connector/ Jumper	Description
P5	Micro USB port to PC Configurator
JW4	Factory set on (closed). Leave as is
JW5	Factory set off (open). Leave as is



Attention: ADVANCED INSTALLER NOTE

Closing JW5 and JW6 on the main board at start-up will revert the panel to the default configuration.

4.3.1 Jumper on Display

The jumper on the back of the display is factory installed on the middle 2 pins.

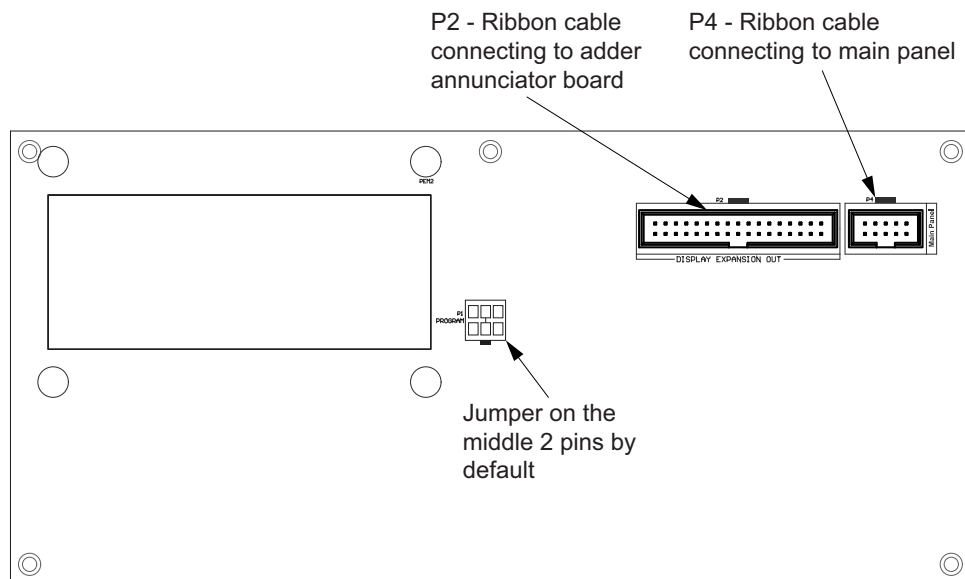

Figure 4 Jumper on Back of Display

4.4 Installing Adder Modules

The FX-401 addressable fire alarm panel is shipped pre-assembled with all main components and boards. Adder modules are not pre-installed.

The following items can be installed in the field:

- PR-300 polarity reversal and city tie module
- PCS-100 power supply interface board
- ALC-480 dual loop adder
- RAX-1048TZDS display adder module
- IPS-2424DS programmable input switches module
- IPS-4848DS programmable input switches module

See the following diagrams for adder module installation locations. For jumper or DIP switch settings refer to Table 2 and for wiring specifications see section 7.1.

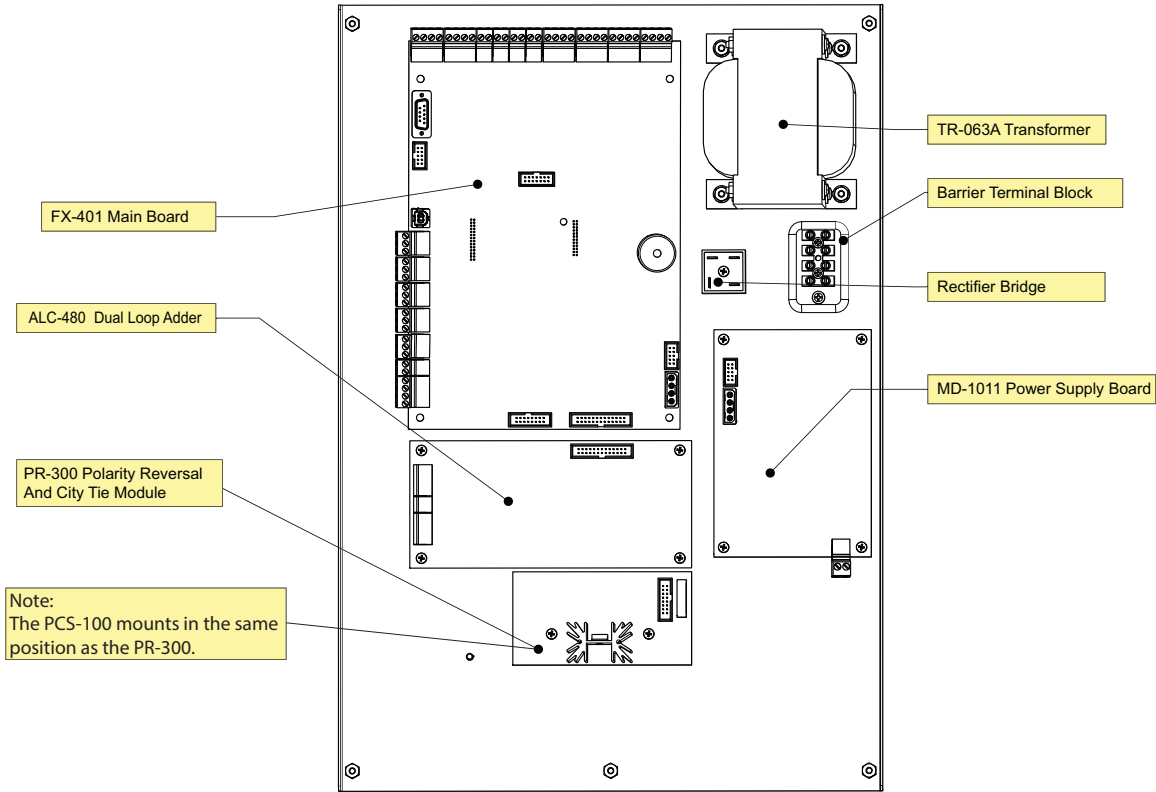

Figure 5 Main Board with all Modules Installed

4.4.1 Installing the PR-300 Polarity Reversal and City Tie Module

Mount the PR-300 as shown in Figure 6.

The alarm transmit signal to the PR-300 can be programmed to turn OFF when signal silence is active. This allows the city tie box to be manually reset. On subsequent alarms the silenceable signals will resound and the city tie box will be retriggered.

The trouble transmit signal to the PR-300 can be programmed to delay AC power fail 0, 1, 2, or 3 hours if this is the only system trouble.

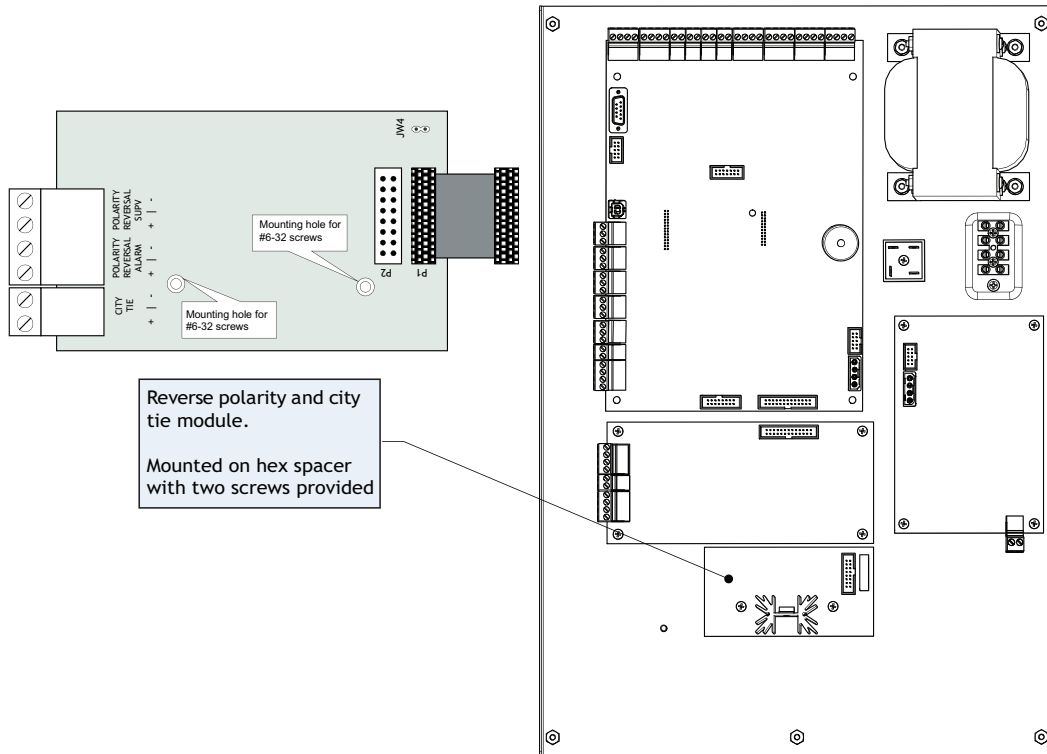

Figure 6 Installing the PR-300 Polarity Reversal and City Tie Module

Table 4 PR-300 Polarity Reversal and City Tie Module Connectors and Jumpers

Item	Setting
P1	Connect cable to P8 on the main board of the FX-401
JW4	Not used. Keep jumper intact



Note: If using a PR-300 remember to remove JW7 on the main board. For the location of JW7 on the main board see Figure 3.

4.4.2 Installing the ALC-480 Dual Loop Adder



Caution: Do not add or remove the ALC-480 dual loop adder when the panel is connected to AC power or batteries. Only add or remove the loop adder when the panel is completely powered off.

Mount the ALC-480 dual loop adder as shown in Figure 7.

The ALC-480 provides two addressable loops (SLC). Each loop can accommodate 240 MIX-4000 series devices.

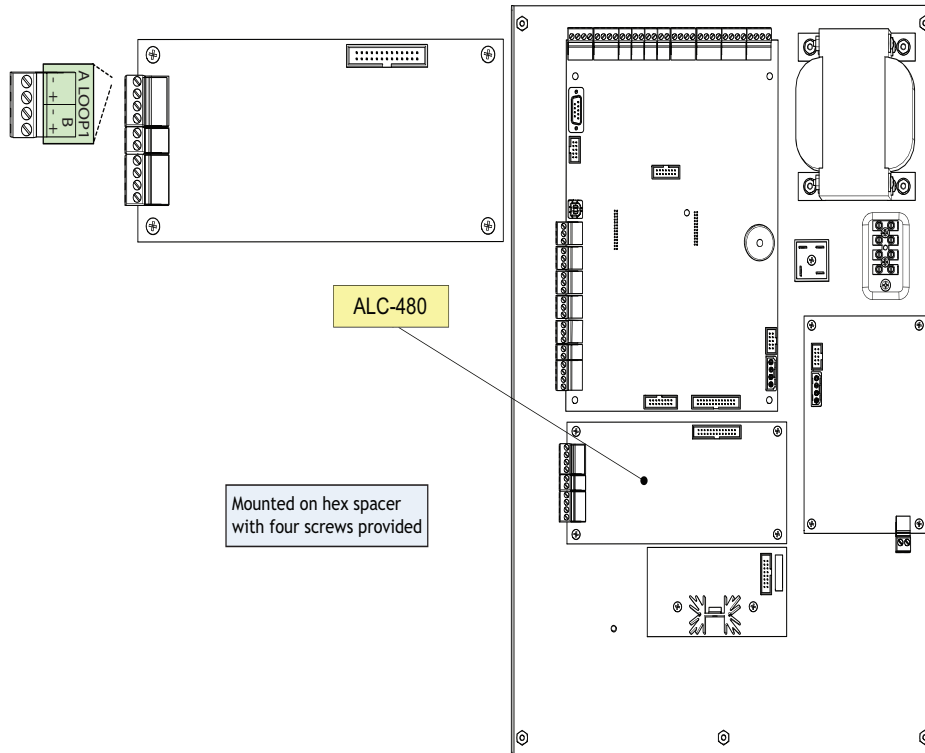

Figure 7 Installing the ALC-480 Dual Loop Adder

Table 5 ALC-480 Dual Loop Adder Connector

Item	Setting
P1	Connect cable to P10 on the main board of the FX-401

4.4.3 Installing the RAX-1048TZDS Display Adder Module

The FX-401 can have a maximum of two RAX-1048TZDS display adder modules. The RAX-1048TZDS mounts in the BB-1000D series annunciator enclosures or in the in the FX-401 main enclosure as part of the fire alarm system. No jumpers or other physical configuration steps are required to install the RAX-1048TZDS display adder modules.

To Install the RAX-1048TZDS Display Adder Module

1. Remove the blank cover plate from the front door and install the RAX-1048TZDS with the clear cover in the opening with the hardware provided.

If you are installing the IPS-2424DS in a BB-1000D series enclosure, install it in the opening with the hardware provided.
2. Disconnect main and standby power and connect the cable of the RAX-1048TZDS into the open header of the main annunciator.
3. If you are installing a second RAX-1048TZDS, connect the cable of the second RAX-1048TZDS into the open, remaining header of the existing RAX-1048TZDS. The additional LEDs will be available for configuration as LEDs 49 to 96, when the system power is restored.

4.4.4 Installing the IPS-2424DS Programmable Input Switches Module

The IPS-2424DS programmable input switches module mounts in the BB-1000D series annunciator enclosures or in the FX-401 main enclosure as part of the fire alarm system. This adder module provides 24 programmable switches, 24 bi-colored (red/amber) LEDs for fire alarm zone annunciation and 24 amber trouble LEDs.

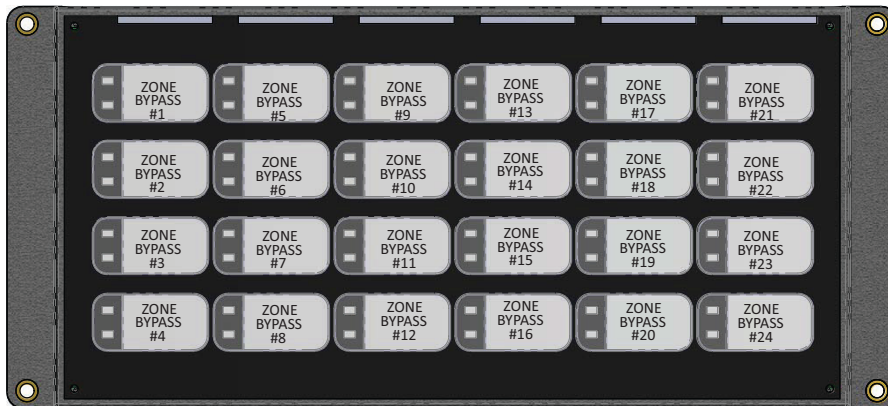

Figure 8 IPS-2424DS Programmable Input Switches Module Front Chassis View

To Install the IPS-2424DS Programmable Input Switches Module

1. Remove the blank cover plate from the front door and install the IPS-2424DS in the opening with the hardware provided.

If you are installing the IPS-2424DS in a BB-1000D series enclosure, install it in the opening with the hardware provided.

2. Disconnect main and standby power and connect the IPS-2424DS as shown in Figure 9.

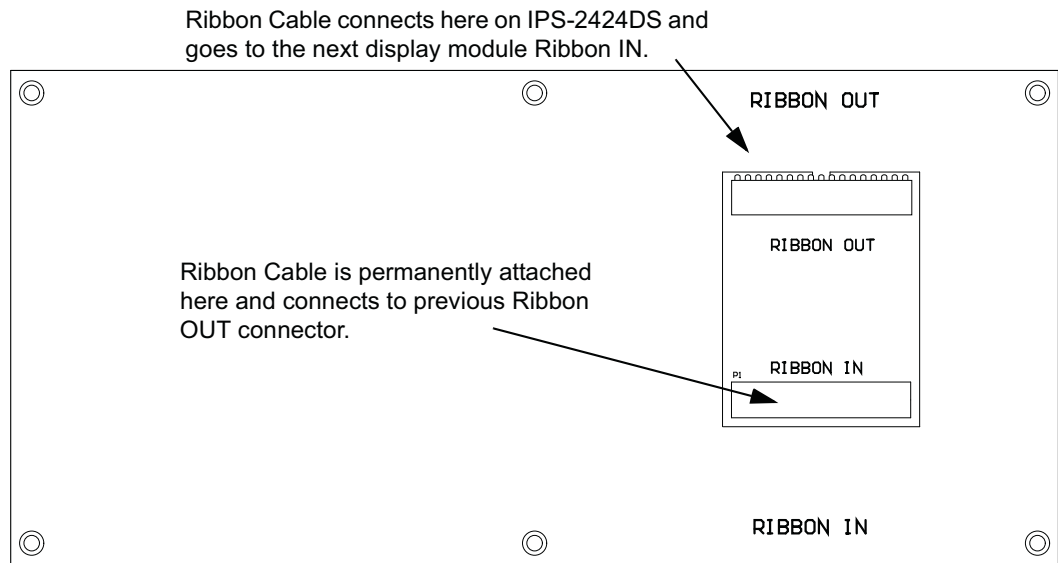

Figure 9 IPS-2424DS Cable Connections

4.4.5 Installing the IPS-4848DS Programmable Input Switches Module

The IPS-4848DS programmable input switches module mounts in the BB-1000D series annunciator enclosures or in the in the FX-401 main enclosure as part of the fire alarm system. This adder module provides 48 programmable switches, 48 bi-colored (red/amber) LEDs for fire alarm zone annunciation and 48 amber trouble LEDs.



Figure 10 IPS-4848DS Programmable Input Switches Module Front Chassis View

To Install the IPS-4848DS Programmable Input Switches Module

1. Remove the blank cover plate from the front door and install the IPS-4848DS in the opening with the hardware provided.

If you are installing the IPS-4848DS in a BB-1000D series enclosure, install it in the opening with the hardware provided.

2. Disconnect main and standby power and connect the IPS-4848DS as shown in Figure 11.

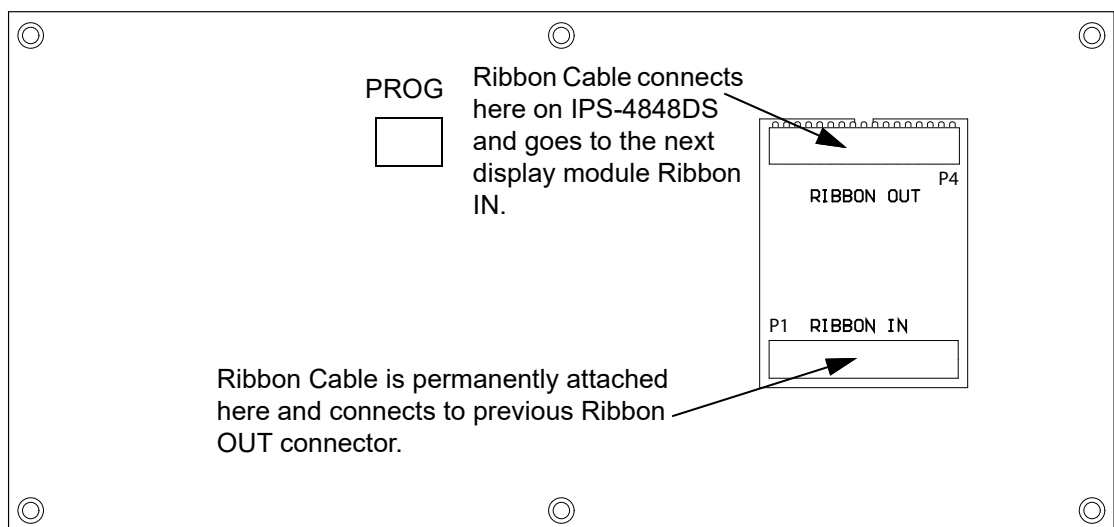

Figure 11 IPS-4848DS Cable Connections

4.5 Annunciators

Connect the annunciators to the RS-485 terminals and to auxiliary power. Use class B wiring for RS-485. For instructions, see the following Mircom documents:

- RAM-3500-LCD: LT-1093
- RAM-1032TZDS(-CC) and RAX-1048TZDS(-CC): LT-617
- RAX-LCD-LITE: LT-1149
- MGD-32 and AGD-048: LT-847

4.6 SRM-312R/SRM-312W Smart Relay Module

Connect SRM-312R/SRM-312W to the RS-485 terminals and to auxiliary power. Use class B wiring for RS-485. For instructions, see LT-1001.

4.7 RTI-1 Remote Trouble Indicator

Connect the RTI-1 to the port labeled **RTI Port**. For instructions, see LT-388.

5.0 Operation

This chapter describes the operational capabilities of the FX-401.

Table 6 Settings Permitted in UL864

NOTICE TO USERS, INSTALLERS, AUTHORITIES HAVING JURISDICTION, AND OTHER INVOLVED PARTIES			
This product incorporates field-programmable software. In order for the product to comply with the requirements in the Standard for Control Units and Accessories for Fire Alarm Systems, UL 864, certain programming features or options must be limited to specific values or not used at all as indicated below.			
Program feature or option	Permitted in UL 864? (Y/N)	Possible settings	Settings permitted in UL 864
Test signal for dialer	Y	6, 12, 24 hours	6 hours maximum
Building/property safety input	N	Not Applicable	Not Applicable
CO supervisory input correlated to NACs sounding T4 pattern	N	Not Applicable	Not Applicable

Table 7 Settings Permitted in CAN/ULC-S527and CAN/ULC-S559

NOTICE TO USERS, INSTALLERS, AUTHORITIES HAVING JURISDICTION, AND OTHER INVOLVED PARTIES			
This product incorporates field-programmable software. In order for the product to comply with the requirements in CAN/ULC S527 Standard for Control Units for Fire Alarm Systems and CAN/ULC-S559 Standard for Equipment for Fire Signal Receiving Centers and Systems certain programming features or options must be limited to specific values or not used at all as indicated below.			
Program feature or option	Permitted in CAN/ULC-S527, S559? (Y/N)	Possible settings	Settings permitted in CAN/ULC-S527, S559
Test signal for dialer	Y	6, 12, 24 hours	6 hours maximum
CO Alarm Priority	N	Enabled, Disabled	Disabled
CO supervisory input correlated to NACs sounding T4 pattern	N	Not Applicable	Not Applicable



Caution: To comply with UL 864 and ULC S527, systems with CO alarms must be monitored by a fire signal receiving center with emergency response, both aspects meeting the Standard for the Installation of Carbon Monoxide (CO) Detection and Warning Equipment, NFPA 720.

5.1 Addressable/Analog Devices

The FX-401 System supports up to 3 loops with a total of 720 MGC addressable devices. Configuration is done via the MGC-400 software configurator.

Additional Information

- The addressable loop can be configured for class A (class X) or class B operation.
- T-tapping is not recommended.
- Unshielded twisted pair (UTP) is recommended.
- A short or open on the loop will activate the common trouble sequence with a latching trouble. (class A only)
- The maximum number of isolators is determined by the loop current.
- The FX-401 FACP will test the sensitivity of a single sensor address every 4 minutes. Each address will be tested once, approximately every 11 hours.

5.1.1 Supervision of Devices

The loop interface software continuously supervises the devices on its loop against those found during configuration for the following conditions:

- Device missing.
- Unconfigured device responding.
- Two or more devices responding to the same address.
- Wrong device type.

A communication or addressing error on a device is reported as a trouble on the associated zone LED as configured. The detectors may be configured as non-verified or verified alarm inputs.

5.1.2 Device LEDs

- Polling the devices on the loop causes the device LED to flash normally.
- All device LEDs can be suppressed via the configurator. **Suppressing the device LEDs causes sounder or relay bases to not operate.** For an unconfigured device, the LED will be steadily red. For a device with a built-in isolator, the LED will be steadily yellow if the isolator is activated.
- Activating devices on the loop (alarm for an input device, active for an output device) illuminates the device LED steady red.
- The maximum number of active MGC devices with their LED illuminated steady red is 40 for the SLC loop.

5.1.3 Alarm Conditions

Alarm conditions are determined by interrupt which uses thresholds for alarm conditions stored in the device.

MGC detectors (MIX-4000 series) send an interrupt request to the panel, indicating the alarm condition. The system is polling the interrupt group to determine the devices in alarm. The alarm conditions are confirmed by device status flag and comparing reported value against the threshold.

Devices can be individually configured with 2 separate thresholds, “day time” and one “night time” or after hours operation. For example, a device may be configured to a low sensitivity for “day time” and high sensitivity at “night time”. The day time threshold will be used unless the after hours operation is active. To configure threshold settings, **Enable Auto After Hours** must be selected in the configurator.

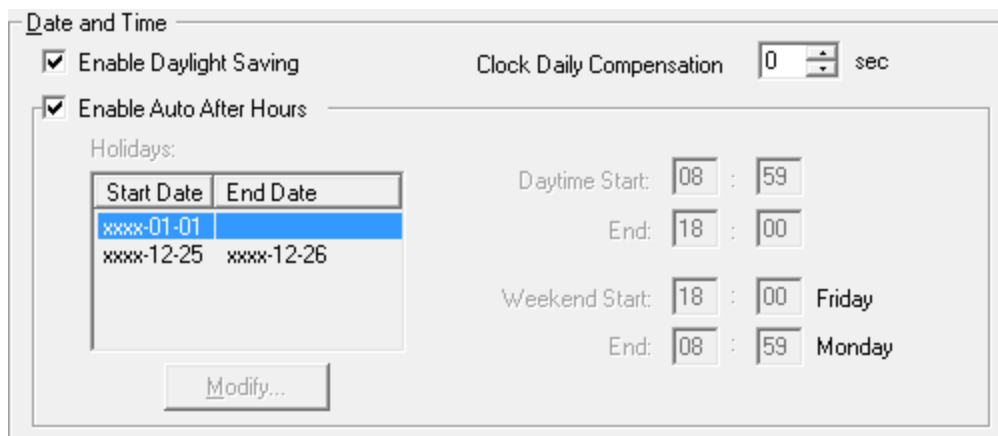

Date and Time

Enable Daylight Saving Clock Daily Compensation: 0 sec

Enable Auto After Hours

Start Date	End Date
xxxx-01-01	xxxx-12-25
xxxx-12-25	xxxx-12-26

Daytime Start: 08 : 59
 End: 18 : 00
 Weekend Start: 18 : 00 Friday
 End: 08 : 59 Monday

Figure 12 MGC-400 Configurator Date and Time Settings

The panel can provide up to 280mA of current to the devices on the loop at normal standby. For device currents see Appendix E.

For further information refer to the device Installation Instructions and other documentation provided with the addressable devices, bases, and isolators.

5.1.4 Drift Compensation

Drift compensation is built into MGC devices (MIX-4000 series), and is not performed by the panel. Drift compensation automatically adjusts for gradually increasing effects of dust and other accumulations of dirt in the detectors. It will adjust the thresholds to compensate for a detector going dirty according to the gradual change in the normal clean air value received. When it can no longer compensate for an increasingly dirty detector, a dirty detector trouble is indicated for that device.

5.1.5 Auto Test

Periodically each detector is commanded to return an alarm value to test its ability to alarm. If the device fails the test, a trouble is indicated for that device. This trouble is latched until system reset.

5.2 Configurable Input Types

Input devices and modules may be configured as one of many possible input types. Table 8 identifies the device types assignable to each input type. For device type descriptions see sections 5.2.1 to 5.2.12.

Table 8 Configurable Input Types

Input Type	As listed in Configurator	Description located in Section	Device Types	
			Detectors	Dual Input Module Mini Dual Input Module Conventional Zone Module
Alarm Input	Alarm Input	5.2.1	X	X
Latched Supervisory	Latched Supv	5.2.2	X	X
Non-Latching Supervisory	Non-Latch Supv	5.2.2	X	X
Building/Property Safety Input	Building	5.2.3	X	X
Priority Alarm	Priority Alm	5.2.4	X	X
Trouble Input	Trouble Input	5.2.5	X	X
Waterflow Alarm Input	Waterflow	5.2.6		X
System Reset	Sys Reset	5.2.7		X
Fire Drill	Fire Drill	5.2.7		X
Acknowledge	Ack	5.2.7		X
Total Evacuation	Total Evac	5.2.7		X
Auxiliary Disconnect	Aux Disc	5.2.7		X

Table 8 Configurable Input Types (Continued)

Input Type	As listed in Configurator	Description located in Section	Device Types	
			Detectors	Dual Input Module Mini Dual Input Module Conventional Zone Module
Buzzer Silence	Buzz Sil	5.2.7		X
Signal Silence	Signal Silence	5.2.7		X
Acknowledge General Alarm	Ack GA	5.2.7		X
Audible Walktest	Audible Walktest	5.2.8		X
Silent Test	Silent Test	5.2.9		X
Manual Day/Night	Manual Day/Night	5.2.10		X
Auto Day/Night	Auto Day/Night	5.2.11		X
Auxiliary Reset	Auxiliary Reset	5.2.7		X
Verified Alarm	Verified Alm	5.2.12	X	
CO Alarm	CO Alarm	5.2.13		X
CO Latched Supervised	CO Latched Supervised	5.2.14		X

5.2.1 Alarm Input (Non-Verified)

An unbypassed, non-verified alarm input entering into alarm activates the common alarm sequence.

Common Alarm Sequence

- Updates unbypassed relay, signal, and strobe outputs based upon their configuration.
- If there are no CO input types configured in the SLC loop, an alarm activates the auxiliary and alarm relays.
- If there are CO input types configured in the SLC loop, an alarm activates only the alarm relay.
- Activates alarm zone status indicators associated with the input.
- Alarm input activations display first and as the highest priority on the shared display in the common queue.
- Devices configured as alarm inputs display a pre-alarm condition on the shared display and on the alarm zone status indicator.
- Restoring the pre-alarm condition clears the status. If the input goes from pre-alarm to alarm, the pre-alarm status will be replaced with the alarm status for the input.
- Devices configured as alarm inputs display an alarm condition on the shared display and on the alarm zone status indicator.
- Once an alarm input is in alarm the alarm condition is latched until system reset (changes in status from alarm to pre-alarm or to normal are ignored).

5.2.2 Supervisory Inputs



Attention: Non-latching supervisory inputs are not permitted in Canada unless done so by the AHJ as per ULC-S527-11 4.6.3.

Devices can be configured as latching or non-latching supervisory inputs. Any unbypassed supervisory input entering alarm activates the common supervisory sequence.

Common Supervisory Sequence

- Updates unbypassed relay, signal, and strobe outputs based upon their configuration.
- Activates the supervisory relay.
- Activates supervisory zone status indicators associated with the input.
- Supervisory input activations display as the second highest priority on the shared display in the common queue.
- Devices configured as supervisory inputs display as supervisory conditions on the shared display and on the supervisory zone status indicator.
- Restoring the non-latching supervisory input returns all outputs correlated to the input, that are not correlated to another active input, to normal.
- Zone display indicators update announcing the input is no longer active and removes the message from the shared display common queue.
- If there are no other active supervisory inputs the common supervisory condition will be restored.

Latched supervisory inputs operate the same as non-latched supervisory inputs with one exception:

- A normal to off-normal status change indication shall be latched and only manually resettable at the control unit or display and control center.

5.2.3 Building/Property Safety (for ULC) Input

Building/property safety inputs may include but are not limited to: fan status, dampers, motors, elevators, telephones, etc.

Building/property safety inputs may be programmed to LED Indicators. The input status will activate the LED as configured.

- Building input activations display as the third highest priority on the shared display in the common queue. They are lower than supervisory and higher than troubles.
- May also be programmed to relay, signal, and strobe outputs.



Caution: Correlating signal and strobe devices to building/property safety inputs requires the approval of the AHJ and are not to be used for fire events.

- When an unbypassed building circuit activates, the status display and programmed outputs are activated.

- Restoring the building status returns all outputs correlated to the input, that are not correlated to another active input, to normal.



Note: Devices used for building inputs are to be isolated from fire operation. It is required that these devices are placed on a separate SLC loop if class B (DCLB) wiring is used, otherwise wire the devices according to class X (DCLC) to accomplish isolation.

5.2.4 Priority Alarm

Increases the polling frequency and optimizes the transmission of data from the device. The auxiliary and alarm relays activate.

- If there are no CO input types configured in the SLC loop, a priority alarm activates the auxiliary and alarm relays.
- If there are CO input types configured in the SLC loop, a priority alarm activates only the alarm relay.

5.2.5 Trouble-Only Input

An active condition on an unbypassed trouble-only input initiates the common trouble sequence as a non-latching trouble.

- Activates trouble zone status indicators associated with the input.
- Trouble input activations display as the lowest priority on the shared display in the common queue.
- May also be programmed to relay, signal, and strobe outputs.



Note: Trouble conditions initiated as a result of a trouble-only input activating is separate from the circuit or device supervision trouble.

5.2.6 Waterflow Alarm Input

Waterflow inputs are sampled every second. 10 samples in alarm in any given 15 second period confirms the alarm condition. Therefore from a continuous input activation the alarm will be processed within 10s.

- If there are no CO input types configured in the SLC loop, a waterflow alarm activates the auxiliary and alarm relays.
- If there are CO input types configured in the SLC loop, a waterflow alarm activates only the alarm relay.

LED Indication

The alarm zone LED indicator flashes when one sample indicates an alarm condition. If the alarm is confirmed the LED indicator will illuminate steady. If 15 seconds elapses without any samples in the alarm condition the LED Indicator will turn OFF. The waterflow retard operation operates regardless of whether or not the system is in alarm.



Note: Do not use the retard operation with any external retarding device.

5.2.7 System Status Correlations

The following system status processes can be correlated to configured (mini) dual input modules:

- System Reset
- Fire Drill
- Acknowledge
- Total Evacuation
- Buzzer Silence
- Signal Silence
- Acknowledge General Alarm
- Auxiliary Disconnect



Attention: Devices correlated with any of the above system statuses need to be contained within a secured enclosure accessible only to those with the proper authority.

5.2.8 Audible Walktest

Configures (mini) dual input modules as audible when conducting a walk test. For more information on performing a walk test see section 5.11.5.

5.2.9 Silent Test

Configures (mini) dual input modules as silent when conducting a walk test. For more information on performing a walk test see section 5.11.5.

5.2.10 Manual Day/Night

Configures (mini) dual input modules for manual day/night alarm thresholds. For more information on alarm thresholds see section 5.1.3.

5.2.11 Auto Day/Night

Configures (mini) dual input modules for auto day/night alarm thresholds. For more information on alarm thresholds see section 5.1.3.

5.2.12 Verified Alarm Input

Unbypassed verified alarm inputs entering into alarm are verified over a period of time to determine if the alarm condition is valid.

Addressable / Analog Device Verification Process

If the system is not already in alarm:

1. A device entering into alarm initiates a 30 second delay timer.
2. When the 30 second delay times out the device is monitored for the next 60 seconds.

3. If the same device enters into alarm again during this time the alarm is confirmed. The following will also confirm the alarm:
 - Any additional alarm input activating aborts the verification process and confirms the alarm.
 - Any trouble detected on the circuit being verified aborts the verification process and confirms the alarm.

If there are no CO input types configured in the SLC loop, a confirmed verified alarm activates the auxiliary and alarm relays.

If there are CO input types configured in the SLC loop, a confirmed verified alarm activates only the alarm relay.

LED Indication

The alarm zone LED indicator flashes for the duration of the verification process. If the alarm is not confirmed the LED turns off. If the alarm is confirmed the LED illuminates steady.

5.2.13 CO Alarm

A CO alarm circuit has CO detectors connected to it. Activation of one of these devices immediately results in a CO alarm condition in the fire alarm control panel. A CO alarm condition causes the associated circuit status LED and the CO ALARM LED to illuminate amber, and the indicating circuits to sound at the temporal 4 rate. The auxiliary relay activates.

5.2.14 CO Supervisory

A CO supervisory circuit has CO detectors connected to it. Activation of one of these devices immediately results in a latching CO supervisory condition in the fire alarm control panel. A CO supervisory condition causes the associated circuit status LED and the SUPERVISORY LED to illuminate amber. The buzzer sounds at the supervisory rate. The supervisory relay activates. A CO supervisory circuit can be correlated to indicating circuits.

5.3 Output Types

Output devices and modules may be configured as one of many possible output types. Table 9 identifies the device types assignable to each output type. For device type descriptions see sections 5.3.1 to 5.3.3

Output modules on the addressable/analog loop may be configured as any of the following output types:

- Signals
- Strobes
- Relay outputs

Table 9 Configurable Output Types

Output Type	As listed in Configurator	Description located in Section number	Device Types	
			Dual Relay Module	Supervised Output Module
Relay	Relay	5.3.3	X	X
Signal	Signal	5.3.1	X	X
Strobe	Strobe	5.3.2	X	X

Additional Operation Features

- The panel can synchronize strobes directly without the use of the synchronous module.
- Depending on the device, the system can detect open and short troubles and report it as an output circuit trouble.

5.3.1 Signal Output

For audible devices such as bells and piezo mini-horns, signals operate in alert (two stage) and/or evacuation rate.

5.3.2 Strobe Type Settings

Normal (non-synchronized)

- Strobe circuits operate similar to signals except that they are always turned ON continuously (they are not affected by the alert or evacuation rates) if configured as Normal.
- Configuring strobes as Normal does not use a sync protocol for the output circuit.
- Silenceable or non-silenceable.

Synchronized

Output circuits can be configured with various synchronization protocols.

When the output circuit is configured as strobe and also configured as non-silenceable and the device used on the output is a combination of horn and strobe, then if the signal silence is activated while the circuit is active the horn(s) are silenced while the strobe keeps on flashing.

Synchronized strobes and strobe/horn models of the following manufacturers are supported: Mircom, System Sensor, Wheelock and Gentex.



Note: Silencing of the horn depends on the feature provided by the manufacturer of the horn/strobe combination. Some models of the horn/strobe combination may not have this feature and will not work as described above.

5.3.3 Relay Output

Unbypassed relay outputs are activated if any unbypassed input circuit or common system status which has been programmed to it is active. If the relay is configured as silenceable it is inhibited when common auxiliary disconnect is active. Relays also turn off if they are bypassed or if all inputs and system statuses correlated to the relay output are restored or bypassed.

5.4 NAC Circuit Operation

NAC Circuits can be configured as

- Signal Output
- Strobe Output
- Relay Output

For more information on outputs see section 5.3.

Powered output circuits are supervised while they are not active for both open circuits and shorts.

The circuit will not be activated if there is a short trouble on the circuit. It will be activated if an open trouble is indicated. A circuit trouble activates the common trouble sequence as a non-

latching trouble. Since open circuit supervision does not operate while the circuit is in alarm, if the circuit was in trouble before it was activated, it will still indicate trouble while active. The trouble condition will be re-evaluated when supervision resumes.

Output circuits configured as strobes can have sync protocol for synchronization if configured. Certain strobe and strobe/horns models of the following brands are supported:

- Mircom
- System Sensor
- Wheelock
- Gentex

When configured as normal, the output circuit is ON continuously when activated and does not use any sync protocol. When configured as non-silenceable strobes, the strobes cannot be silenced, but the horn can be silenced by pressing the 'signal silence' button.

If the strobe is configured as silenceable strobe both the horn and the strobe are silenced (stopped) by pressing the 'signal silence' button.

5.5 Single Stage Operation

In a single stage system, all alarm inputs are treated in a similar manner. Alarm inputs include any of the following:

- Non-verified alarm
- Verified alarm
- Waterflow alarm
- Sprinkler alarm

Any of the above alarm inputs activating when the panel is not already in alarm cause the following:

- The buzzer sounds steady.
- Cancels active fire drill.
- Common alarm LED (ALARM QUEUE) turns ON.
- Common alarm relay activates if aux disconnect is not active.
- The auto signal silence timer activates (if configured).
- The signal silence inhibit timer activates (if configured).
- If aux disconnect is not active, activates all non-disconnected indicating circuits programmed to the input.
- Activates non-disconnected strobes associated with the input.
- Activates non-disconnected signals associated with the input at the evacuation rate.

Subsequent alarms when the panel is already in alarm, cause the following:

- The alert buzzer sounds steady.
- Resounds silenced signals, turns off the signal silence LED, and restarts the auto signal silence timer (if configured).
- Activates continuously any additional non-disconnected strobes associated with the input.
- Activates at the evacuation rate any additional non-disconnected signals associated with the new input.

5.6 Two-Stage Operation

In a two stage system, alarm inputs are either first stage (alert) inputs or second stage (general alarm) inputs. First stage inputs include inputs from the following types of circuits:

- Non-verified alarm
- Verified alarm
- Sprinkler alarm
- Water-flow alarm

Second stage inputs include the following:

- Alarms on the general alarm inputs.
- Activation of the general alarm button.
- Expiration of the auto general alarm timer.

Any of the above alarm inputs activating when the panel is not already in alarm cause the following:

- The buzzer sounds steady.
- Cancels active fire drill.
- Common alarm LED (ALARM QUEUE) turns ON.
- Common alarm relay activates if aux disconnect is not active.
- The auto signal silence timer activates (if configured).
- The signal silence inhibit timer activates (if configured).
- If aux disconnect is not active, activates all non-disconnected indicating circuits programmed to the input.

If the alarm is a second stage alarm, the following occurs:

- Activates non-disconnected strobes associated with the input.
- Activates non-disconnected signals associated with the input at the evacuation rate.
- The GENERAL ALARM LED illuminates steady.

If the alarm is a first stage alarm, the following occurs:

- Activates continuously non-disconnected strobe circuits programmed to that circuit.
- Activates with the alert code non-disconnected signal circuits programmed to that circuit.
- Activates the auto general alarm timer (if configured).
- Acknowledge LED flashes.

Subsequent first stage alarms when the panel is already in alarm, cause the following:

- The buzzer sounds steady.
- Resounds silenced signals, turns off the signal silence LED, and restarts the auto signal silence timer (if configured).
- If the panel is not already in general alarm, activates additional non-disconnected signals programmed to the new input with the alert code (see section 5.3).
- If the panel is not already in general alarm and the acknowledge LED is ON steady indicating that the auto general alarm timer has been acknowledged, restarts the timer and extinguishes the Acknowledge LED.

A second stage alarm (general alarm) when the panel is already in alarm causes the following:

- The buzzer sounds steady.

- Activates all non-disconnected signals at the evacuation rate.
- If the signal silence LED is ON, it turns OFF and restarts the auto signal silence timer (if configured).
- If the Acknowledge LED is ON, turns the LED OFF.
- The GENERAL ALARM LED illuminates steady.

Alarm inputs are latching, they remain active until system reset.



Note: All circuits with process type designated as “signal or strobe” are automatically correlated to the “fire drill” and “general alarm” status.

5.7 Evacuation Codes

The following Evacuation codes can be configured for the FX-401 FACP.

Continuous	On 100% of the time.
Temporal Code	0.5 second on and 0.5 second off repeated 3 times 1.5s pause
March Code	0.5 second on 0.5 second off.
California Code	5 seconds on 10 seconds off.
Temporal Code 4 (for Carbon Monoxide Signal)	0.1 second on, 0.1 second off, 0.1 second on, 0.1 second off, 0.1 second on, 0.1 second off, 0.1 second on, 5 seconds off, then repeat.

5.7.1 Two Stage Alert Code

When configured for two stage operation, the FX-401 FACP uses a pre-configured alert code that sounds prior to the evacuation code.

Alert Code	0.5 second on, 2.5 seconds off.
-------------------	---------------------------------

5.8 Positive Alarm Sequence

In a Positive Alarm Sequence (PAS) system, only smoke detectors can be dedicated as PAS inputs. PAS Inputs can only be from the following process types:

- Non-verified alarm
- Verified alarm

Any of these alarm inputs activating when the panel is not already in alarm causes the following:

- Buzzer sounds steady.
- Cancels active fire drill.
- Common alarm LED (ALARM QUEUE) turns ON.
- Individual zone LED (if programmed) turns ON.
- Common alarm relay does not activate.
- PAS timer starts for 15 seconds.
- All outputs programmed to the input are not activated.

When the PAS alarm has been acknowledged by pressing the ALARM ACK button within 15 seconds, the following sequence occurs:

- Buzzer silences
- Common alarm LED (ALARM QUEUE) remains ON.
- Individual zone LED (if programmed) remains ON.
- PAS timer starts for 180 seconds (3 minutes). This is the time allotted to reset the system and avoid any true alarm sequence.

When the PAS alarm has been acknowledged within the given time limits and the system resets, the following occurs:

- The buzzer remains silenced.
- Common alarm LED (ALARM QUEUE) turns OFF.
- Individual zone LED (if programmed) turns OFF.
- Cancels the alarm event with no log reference.
- Fire alarm system returns to normal.

If at any time during the Positive Alarm Sequence a second alarm (PAS or otherwise) is actuated or the given time limits expire, the fire alarm will go into evacuation mode and the following occurs:

- Common alarm relay activates if aux disconnect is not active.
- The auto signal silence timer activates (if configured).
- The signal silence inhibit timer activates (if configured).
- If aux disconnect is not active, activates all non-disconnected indicating circuits programmed to the input.
- Activates non-disconnected strobes associated with the input.
- Activates non-disconnected signals associated with the input at the evacuation rate.

In a preconfigured FACP the Positive Alarm Sequence may be enabled or disabled as the user requires. For more information on enabling or disabling the Positive Alarm Sequence see section 5.8.1.

5.8.1 Enabling or Disabling the Positive Alarm Sequence

Enabling or disabling the Positive Alarm Sequence is done using the numeric keypad. For more information on how to use the numeric keypad see section 6.2.1.

How to enable or disable the Positive Alarm Sequence

1. From the keypad of the FACP press M to enter the Menu.
2. Using the Up and Down cursor buttons, scroll to **Operation**.
3. Press Enter.
4. In the **Operation Menu** scroll to **Positive Alarm**.
5. Press Enter.
6. You will now see the current status of the **Positive Alarm Sequence** and will be prompted to change status.

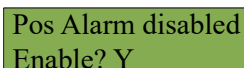

```
Pos Alarm disabled
Enable? Y
```

Figure 13 Enabling the Positive Alarm Sequence

7. To change the status press **Enter**.



Note: Positive Alarm Sequence needs to be configured in the configuration job file before it is sent to the panel. There will be no notification message advising a change of status.

8. To exit without changing the status press **Cancel**.

How to enable the Positive Alarm Sequence in the MGC-400 Configurator

1. In the Job Details window, check the **Positive Alarm Sequence** box.

This option only applies to alarm input devices with the PA flag (F2) set.

5.9 Remote Annunciator Operation

The FX-401 system supports the following types of annunciators (class B).

- RAX-LCD-LITE shared display annunciator.
- RAM-3500-LCD shared display annunciator.
- Conventional LED/switch annunciators.

Both shared display RAX-LCD-LITE and RAM-3500-LCD annunciators are connected to the panel via the RS-485 serial link (class B).

The maximum number of annunciators is seven (7). Configuration of the annunciators is done via the MGC-400 software configurator.

Ensure that the address DIP switch on each annunciator is set to the same value set in the configurator. Only the first three (3) DIP switches are used for address configuration.

Table 10 Annunciator Address DIP Switch Settings

Address	SW1-1	SW1-2	SW1-3
1	ON	OFF	OFF
2	OFF	ON	OFF
3	ON	ON	OFF
4	OFF	OFF	ON
5	ON	OFF	ON
6	OFF	ON	ON
7	ON	ON	ON

5.9.1 Supervision of Annunciators (Class B)

- The communications with each annunciator is constantly supervised by the panel and the annunciator.
- If communications fails, the panel will activate the common trouble sequence. The number of annunciators is set during panel configuration.
- If there is a mismatch in the total number of annunciators the panel will generate communications trouble.

- The panel trouble is non-latching: when the correct number of annunciators is detected the troubles will clear.

5.9.2 RAX-LCD-LITE Shared Display Annunciator

- The RAX-LCD-LITE is equipped with a large 4 line x 20 character backlit alphanumeric LCD display which uses a simple menu system complete with a directional key pad and switches for Enter, Menu, Cancel and Info.
- Contains a local alert buzzer.
- Under normal operation the alert buzzer is controlled by the system and operates in an identical manner as the one in the main panel.
- If communication fails the buzzer is processed locally.

5.9.3 RAM-3500-LCD Shared Display Annunciator

- The RAM-3500-LCD operates identically to the main LCD FACP display.
- Contains a local alert buzzer.
- Under normal operation the alert buzzer is controlled by the system and operates in an identical manner as the one in the main panel.
- If communication fails the buzzer is processed locally.

5.9.4 Conventional Annunciators

The FX-401 system is designed to interface with the RA-1000 series of conventional LED annunciators. The LEDs may be configured to zone status indicators. Each conventional annunciator contains a local alert buzzer. Under normal operation the alert buzzer is controlled by the system and operates in an identical manner as the one in the main panel. If communication fails it is processed locally.

5.9.5 SRM-312R/SRM-312W Smart Relay Module

- Connects on the RS-485 loop along with other remote annunciators.
- Provides 12 relay contact outputs which actuate according to the first 12 remote LED groups.
- Relays are bypassed by auxiliary bypass
- Supervised as one of the (maximum) seven permitted annunciators.

5.10 Dialer Operation

The FX-401 is equipped with a built-in dialer. The dialer provides a means to communicate panel status to the remote central monitoring station using two dedicated phone lines. The two standard protocols for communicating with the central monitoring station are supported by this panel are as follows.

- SIA Format Protocol
- SIA Contact ID



Attention: As per UL864 R10 section 41.3.2.13 the dialer is not to call a number that is call forwarded.

The automatic telephone line test and trouble report must be sent to the same supervising station.

5.10.1 Event Reporting

Events are reported in a special format depending upon the protocol selected. For a complete description of the reporting codes see Appendix C.

5.10.2 Telephone Line Supervision

See section 7.6.1 for the wiring diagram. The phone lines are supervised for the presence of:

- DC voltage.
- Dial tone, stuttered dial tone and message waiting tone.

Supervision is carried out every two minutes as follows:

1. DC voltage is supervised and if it is detected the dial tone is monitored.
2. If the phone lines are equipped with a house phone with proper connection and is in use the DC voltage supervision is suspended until the house phone is ON-HOOK again. However, the system then does off-hook current monitoring supervision to ensure that the phone line is operational.
3. If there is an event to be reported in the dialer queue and the house phone is in use the dialer tries the second line to report the event.
4. If that line's house phone is also in use the dialer seizes the line. The dialer disconnects the house phone and reports the event to the central monitoring station.

5.11 Using the Operation Menu from the Control Panel

Operations of the FX-401 addressable fire alarm control panel can be managed via the Operation Menu on the LCD shared display. Accessing the menus is done via the numeric keypad and cursor buttons. For a complete description of how to use the numeric keypad and cursor buttons see section 6.2.1.

The following items can be accessed through the Operation Menu:

- Setting the time on the system
- Setting the passcode on the system
- Viewing reports
- Clearing logs
- Walk test function
- Bypass operation
- Disconnecting auxiliary relays
- Testing the dialer
- After hours operation
- Clearing verification counts
- Ground fault testing - factory use only

Complete configuration of the system is done via the MGC-400 software configurator.



Note: See section 6.2.1 for instructions on using the numeric keypad to navigate the menus.

How to Enter the Operation Menu

1. Press the Menu button.
2. Use the Down button to scroll to **Operation** and press the Enter button to enter the Operation Menu.

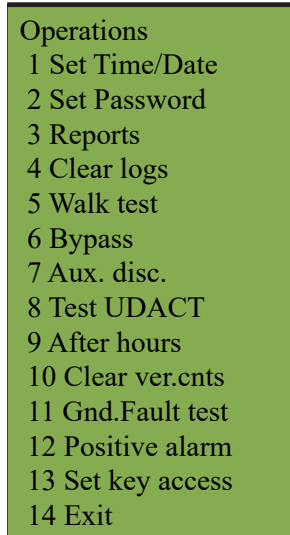
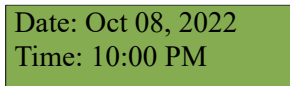

Figure 14 Operation Menu

3. To select an Operation use the Down button to scroll to desired choice and press the Enter button.

5.11.1 Setting the Time



Use the 6 and 8 buttons to move the cursor forward and the Up and Down button to change the date and time.

5.11.2 Setting the Password

This feature sets the passcode for all three access levels. The minimum number of digits for a passcode is 4 and the maximum is 10. For changing a specific level of passcode, the passcode required is the equivalent level or higher level. The highest level is 3 and the lowest level is 1.

1. Press the Up or Down button to select an access level, then press the Enter button.

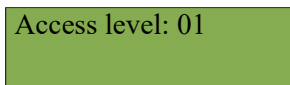

2. Enter the passcode for the current access level or higher.

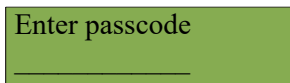

If an incorrect passcode is entered, an invalid passcode message appears. You have three attempts to enter the correct passcode. After three failed attempts the display reverts back to the main operation menu.

```
Invalid passcode
```

3. If the passcode is correct, enter the new passcode and press the Enter button.

```
Enter new passcode
```

4. To confirm the passcode, re-enter the passcode and press the **Enter** button.

```
Re-enter passcode
```

5.11.3 Reports

Overview

Reports are generated in command mode from the reports menu.

```
Report Menu
1 Alarm Log
2 Event Log
3 Current Levels
4 Obscuration
5 Verif Counts
6 Maint Report
7 M/P Report
```

For each report, the system asks you to select an output.

```
- Report To -
1 Printer
2 Screen
```

If you select **Printer**, then for all the logs except Alarm Log and Event Log, the system asks you to select the address range. **All** selects all addresses from all configured loops and **Loop** selects addresses from one loop.

```
1 All
2 Loop
```

If you select **Loop**, then enter a loop number.

```
Loop Number
Loop: _
```

If the panel does not have a printer connected or if you selected **Screen** under the **Report To** menu, the option depends on the kind of report and is described in the appropriate section below.

1. Alarm log

The alarm log report displays the contents of the alarm event log on the shared display which contains the last 400 of any of the following events:

- Activation of any alarm input or common control which activates the common alarm sequence.
- Activation of system reset.
- Clearing of the event log (as the first entry).

Each entry contains the time and date of the event and a description of what the event was, for example:

```
Event 001 of 002
Alarm activated
L1-007.1
Sep 15, 2022 02:18:00
```

The first line shows the position of the event in the queue along with the total number of events in the queue. The second line shows the alarm event, and the third line shows the device address.

Press the Up and Down buttons to scroll through all the events. Press the Info button to see more information about the selected event.

2. Event logs

The general event log report displays the contents of the general event log on the shared display which contains the last 400 of any of the following events:

- Activations of any input circuits.
- Restoration of non-latching input circuits.
- Pre-alarm on any device.
- Initiation of the alarm verification sequence on a verified alarm input.
- Any system troubles.
- Activation of any system common control or any command on the command menu.

The report format is similar to the alarm log report. Each entry contains the time and date of the event and a description of what the event was, for example:

```
Event 001 of 041
Reports command
selected
Jul 26 2023 13:03:04
```

Press the Up and Down buttons to scroll through all the events. Press the Info button to see more information about the selected event.

3. Current levels

The current levels report displays real-time device information for the device you specify or for all eligible devices on the target loop. Eligible devices are those present in the configuration and also those detected as present on the SLC addressable loops.

The system asks you to choose a single address or all addresses.

1. Press the Up or Down button to choose **Y** or **N**, then press Enter.

```
Single address? Y
```

2. If you selected **Y**, enter the loop and device address. Press the * and # buttons to move the cursor left and right.

```
Device address
```

```
L_ _ . _ . _
```

3. If you selected **N**, the system asks you to select the address range. Press **All** to select all addresses from all configured loops and press **Loop** to select addresses from one loop.

```
1 All
2 Loop
```

The display shows the loop number, device address, the device type, device status, and the percent of alarm if the device is an input, in the following format:

```
L1 - 006.1
Current Level: 32
Percent Alarm: 0%
```

4. Press the Up and Down buttons to scroll through all the devices on the loop.
5. Press the Info button to see more information about the selected device.

```
L1 - 006.1
Smoke detector
```

4. Obscuration

This option reports on the obscuration levels of the smoke detectors.

The system asks you to select the address range.

1. Press **All** to select all addresses from all configured loops and press **Loop** to select addresses from one loop.

```
1 All
2 Loop
```

The display shows the current obscuration percentage for the selected smoke detector.

```
L1 – 006.1  
Current Obsc: 0.00%
```

2. Press the Up and Down buttons to scroll through all the smoke detectors on the loop.
3. Press the Info button to see more information about the selected smoke detector.

5. Verify counts

The verification count report displays the number of times that the alarm verification cycle has been initiated without causing an alarm for all verified devices or circuits on the specified loop or loops.

The system asks you to select the address range.

1. Press **All** to select all addresses from all configured loops and press **Loop** to select addresses from one loop.

```
1 All  
2 Loop
```

The report shows the loop number, device address and verify count in the following format:

```
L1-006.1  
Verification  
count: 000
```

2. Press the Up and Down buttons to scroll through all the devices on the loop for which the verify count is available.
3. Press the Info button to see more information about the selected device.

If the count is zero, the device is not displayed. If there are no verified devices on the loop the following message appears.

```
No verified devices  
found
```

Verification counters are cleared by the “Clear Verification Counts” command and at initial power-up.

6. Maintenance report

The maintenance report displays all smoke sensors on the specified loop or loops detected as dirty (% alarm > 75). The percent of alarm rises as the detector gets dirty. A trouble occurs once the percentage reaches 75%.

The system asks you to select the address range.

1. Press **All** to select all addresses from all configured loops and press **Loop** to select addresses from one loop.

```
1 All
2 Loop
```

The report shows the device address, and percentage dirty.

```
L1-006.1
Percent dirty :012%
```

2. Press the Up and Down buttons to scroll through all the devices on the loop for which the maintenance report is available.
3. Press the Info button to see more information about the selected device.

If there are no dirty devices on the loop the following message appears.

```
No dirty devices
found
```

7. M/P Report

The MGC Protocol (MP) Report displays all local parameters of an MGC Protocol device currently connected on the SLC. This feature will list the internal register values of current MGC Protocol devices. Use this tool to report information to Mircom technical support.

1. Enter the loop and device address.

```
Device address
L _ _ . _ .
```

The report lists all the parameters of all the addresses related to the selected device. **Crt.** indicates report line number, **Parm#** indicates the parameter number from the current address, and **Val** indicates the parameter value.

```
Crt. Parm# Val
1 Type=2
2 Addr=6
3 Lp=1
```

Press the Info button to see information about panel firmware.

5.11.4 Clear Logs

This feature the logs stored in the flash memory.

1. Press the **Up** and **Down** cursor keys to select the desired log to be cleared and press the **Enter** button.

```
Select Log
1 Alarm Log
2 General Log
3 All Logs
```

A message asks you for confirmation.

2. Press the Up or Down button to choose **Y** or **N**, then press Enter.

```
Are you sure you
want to clear all
the entries in the
selected log(s)? Y
```

After confirmation the logs are cleared and the following information message appears.

```
Log(s) cleared
```

5.11.5 Walk Test

This feature initiates a silent or audible walk test. The following events occur when in walk test mode:

- Generates a non-latching trouble that clears after exiting the walktest.
- Cancelling the walk test is done by pressing the Cancel button or if no circuit activations are detected for one hour.
- Zone indicators, including the Smart Relay Module (SRM-312R) function normally during the test, displaying the input status when it is activated.
- Other Relays and signal correlations to input circuits are not processed during walk-test. Correlations to system status will still be processed.
- All common controls and keys not explicitly required for the walk-test operation are disabled while the walk-test is active.
- The alarm verification and waterflow retard operations are disabled on inputs during walk-test.

During an audible walk test:

- Activating any input activates all signals for half a second.
- Trouble on any input activates all signals continuously for 5 seconds. After the code is transmitted, the input resets (if resettable) and is tested again. If it is still in alarm or trouble the code will be re-transmitted.

Use the Up and Down buttons to scroll to the desired option, then press the Enter button.

```
Select Test Type
1 Audible Test
2 Silent Test
```

While the walk test is active, the following message appears:

```
- Walktest Active -  
Alarms: nnn  
Troubles: mmm  
Press ENTER to end
```

The numbers **nnn** and **mmm** are continuously updated counts of the number of alarms and troubles which have been recorded during the test (alarms includes all input circuit types tested).

Selective Output Testing

The walk test can be operated with only a selection (up to 64) of outputs. To do this, select audible test.

```
Select all NACs for  
the walk test? Y
```

Select **N** by pressing the Up button, press Enter, and the next screen will show:

```
NACs selected
```

Use the left and right arrow buttons to move through the outputs you want to activate during walk test.



Note: Each event during the walk test is also recorded in the log. Therefore, any event past the 200 count will clear the log and be entered as event 1 and so on.

Walk Test Report

When you stop the walk test, the walk test report appears.

```
Walktst 1 of 2  
Sep 21, 2022 04:14PM  
Walktest  
in progress
```

Press Up or Down to see the other pages of the walk test report.

5.11.6 Bypass

The bypass operation has the following options.

```
Bypass menu
1 Device/Circuit
2 Group
3 Loop
4 List bypass
5 List unbypass
```

1. Device/Circuit Bypass

This option bypasses individual devices. The system asks for the device's loop number and the device address to be bypassed.

Enter the loop and device address.

```
Device Address
L_ - ____._
```

The system asks if you want to bypass all the subaddresses of the selected device.

3. Press the Up or Down button to choose **Y** or **N**, then press Enter.

```
All sub-addresses?Y
```

If the device is not bypassed, you are prompted to bypass the circuit.

4. Press the Up or Down button to choose **Y** or **N**, then press Enter.

```
FLOOR 4 ALARM
L1- 002.1 not
bypassed. Bypass? Y
```

If you selected **Y**, the message appears that the device is bypassed.

```
Device/circuit
bypassed.
```

If you selected to include all the subaddresses, then the system asks if you want to bypass each subaddress.

```
FLOOR 4 ALARM
L1- 002.2 not
bypassed. Bypass? Y
```

If you selected not to include all the subaddresses, then the system asks for the next device to be bypassed.

Device/Circuit Unbypass

The procedure for unbypassing a device is the same as for bypassing a device. If the device is already bypassed, the system will ask if you want to unbypass it.

```
FLOOR 4 ALARM
L1- 002.1 is now
bypassed. Unbypass? Y
```

```
Device/circuit
unbypassed.
```

2. Groups

This option bypasses configured bypass groups. The list of configured bypass groups is displayed and you can select which group to bypass.

```
Bypass groups
1 Bypass Floor A
2 Bypass Floor B
3 Bypass Floor C
```

Scroll up or down to select a group and press Enter. If the selected group is not bypassed, the system prompts you to bypass the group.

```
Grp not bypassed.
Bypass? Y
```

After the confirmation, a message says that the group is bypassed.

```
Group bypassed.
```

Group Unbypass

If the group is already bypassed, the system prompts you to unbypass the group.

```
Group is now bypassed.
Unbypass? Y
```

After the confirmation, a message says that the group is unbypassed.

```
Group unbypassed.
```

3. Loop

This option bypasses a whole conventional or addressable loop.

Enter the loop number to be bypassed.

```
Loop number  
L_
```

If the loop is not already bypassed, the system prompts you to bypass the loop.

```
Loop 1 currently  
not bypassed  
  
Bypass? Y
```

After the confirmation, the loop is bypassed and a bypass confirmation message appears.

```
Loop bypassed.
```

Loop Unbypass

If the loop is already bypassed, the system prompts you to unbypass the loop.

```
Loop 1 currently  
bypassed  
  
Unbypass? Y
```

After the confirmation, an unbypass confirmation message appears.

```
Loop unbypassed.
```

4. List Bypass

This option bypasses a list of devices.

The system prompts you to enter the loop number associated with these devices.

Loop number
L_

Enter the address list of devices you wish to bypass. Use the following symbols to enter the address list:

Table 11 List Bypass Special Characters

Symbol	Number of times to press "1" button	Description
-	2	Sets the interval of consecutive addresses, e.g. 1-7.
,	3	Separates the addresses of the devices
!	4	Placed at the end of list to signify that no individual confirmation is required.

Enter bypass list...

—

The following message appears if the current address carries no device.

Invalid address

The system prompts you to bypass the device.

FLOOR 4 ALARM

L1-002.1 not
bypassed. Bypass? Y

If the device is already bypassed the message is as follows.

FLOOR 4 ALARM

L1-002.1
Already bypassed...

If the exclamation mark is not used, then there will be individual confirmation.

Device/circuit
unbypassed.

At the end of the bypass operation or if the exclamation mark is used, the message shows:



```
Done...
```

5. List Unbypass

This option unbypasses a list of devices.

The system prompts you to enter the loop number to be unbypassed.

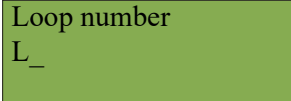

```
Loop number  
L_
```

Enter the list to unbypass. The last list bypassed will be displayed.

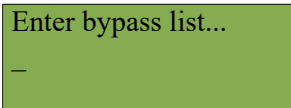

```
Enter bypass list..  
-
```

If the list to be unbypassed is shown, press **Enter** to complete the unbypassing. Otherwise, you may unbypass the devices one, two or more at a time.

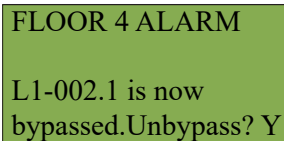

```
FLOOR 4 ALARM  
L1-002.1 is now  
bypassed.Unbypass? Y
```

If you are attempting to unbypass items that are already unbypassed you will see an “Already unbypassed” message.

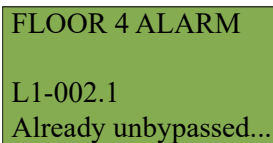

```
FLOOR 4 ALARM  
L1-002.1  
Already unbypassed...
```

Otherwise, if the exclamation mark is not used, then there will be individual confirmation.

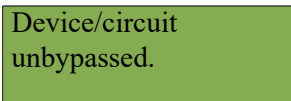

```
Device/circuit  
unbypassed.
```

At the end of the unbypass operation or if the exclamation mark is used, the message shows:



```
Done...
```

5.11.7 Auxiliary Disconnect

The auxiliary disconnect operation is performed by following the steps below. If the auxiliary relays are connected, you are prompted to disconnect the relays. Press the Up or Down button to select **Y** or **N**.

Common aux relays
currently connected.

Disconnect? Y

After the confirmation the auxiliary relays are disconnected and the information message is displayed that the auxiliary relays are disconnected.

Relays disconnected.

If the auxiliary relays are already disconnected, you are prompted to reconnect the relays.

Common aux relays
now disconnected.

Reconnect? Y

After the confirmation the auxiliary relays are reconnected and the information message is displayed that the auxiliary relays are reconnected.

Relays connected.

5.11.8 Test UDACT

This feature lets you test the dialer operation. You can manually test both the phone line L1 and L2 and also reset the dialer where all the events to be reported in the queue are cleared and the dialer status is reset.

UDACT test
1 L#1 Manualtest
2 L#2 Manualtest
3 Reset UDACT

5.11.9 After Hours

This feature lets you manually set the day time or the night time mode of operation and override the current daytime or nighttime mode. The system asks for confirmation as shown below. Press the Up or Down button to select **Y** or **N**.

Day/night mode set
to manual daytime
operation
Change? Y

Enter which mode to be set.

```
Select mode
1 Manual daytime
2 Manual night
3 Auto day/night
```

A message appears showing that the day/night mode is updated.

```
Day/Night mode
updated.
```

5.11.10 Clear Verify Count

This operation is used to clear all the verification counts accumulated during the alarm verification process. The system asks for confirmation as shown below. Press the Up or Down button to select **Y** or **N**.

```
Clear all
verification
counters? Y
```

A message appears saying that the counts are cleared.

```
Counters cleared.
```

5.11.11 Ground Fault Test - Factory Use Only

This feature displays the system ground fault, positive and negative. This feature requires the level 1 passcode. An example of a ground fault test result is shown below.

```
PosGnd: 0.000v
NegGnd: 17.018v
```

5.11.12 Positive Alarm Sequence

If this feature is enabled the system allows for Positive Alarm Sequence (PAS) alarm signals from automatic fire detection devices. This selection is mutually exclusive with Two Stage Operation; that is, you can have one or the other and not both. Any devices deemed PAS will activate the common alarm (ALARM QUEUE) LED, the individual LED (if programmed), flash the Acknowledge LED and sound the alarm buzzer at the panel. The LCD display will also declare the PAS alarm. There will be no alarm signalling initially. All evacuation signal and off-premises signalling will be activated if the Acknowledge button is not pressed within 15 seconds of the PAS alarm and the RESET button is not pressed within 180 seconds from the acknowledge, or if a second device goes into alarm.

Selecting this menu item will have one of three outcomes:

An error message when the feature is not configured:

```
Enable Pos Alarm
option first!
```

An option to enable when the feature is available but has been bypassed:

```
Pos Alarm disabled
Enable? Y
```

An option to disable when the feature is available and enabled:

```
Pos Alarm enabled
Disable? Y
```

5.11.13 Set Key Access

This feature is not used.

5.11.14 Exit

This feature exits to the main command menu.

6.0 Indication and Controls

This chapter describes the LED indicators and controls of the FX-401.

6.1 Indication and Controls

The FX-401 display panel is equipped with the following:

- 12 control buttons with associated LEDs
- 16 button numeric keypad with cursor buttons

Figure 15 shows the LED indicators and control buttons on the FX-401 front display.



Note: The column of LEDs on the right is not used.



Figure 15 LED Indicators and Control Buttons

The FX-401 has the provision for 2 additional RAX-1048TZDS. Each RAX-1048TZDS display adder module provides annunciation for up to 48 zones. Each LED zone has two LEDs.

- 1 red/yellow alarm/supervisory LED.
- 1 yellow trouble LED.

6.2 LCD Display

The display is a four line, 80 character back-lit alphanumeric LCD. It displays information regarding the panel, its circuits, and devices. An on-screen cursor is controlled by the keypad. Information reported by the LCD display includes:

- Alarm log
- Event log
- Current levels
- Device information
- Verification and maintenance reports











Use the cursor buttons on the numeric keypad for menu selection and control. For more information see section 6.2.1.

6.2.1 Numeric Keypad and Cursor Buttons



Figure 16 Numeric Keypad

Table 12 Numeric Keypad and Cursor Buttons

Key	Description
	Key 2 (Up cursor) Press this button to move the cursor or scroll up lists in a continuous loop.
	Key 4 (Left cursor) Press this button to add or remove the X from an option in the Configuration menu. See Appendix B.
	Key 6 (Right cursor) Press this button to add or remove the X from an option in the Configuration menu. See Appendix B.
	Key 8 (Down cursor) Press this button to move the cursor or scroll down lists in a continuous loop.
	Star button Press this button to move the cursor to the left or select options to the left.
	Pound button Press this button to move the cursor to the right or select options to the right.
	Cancel button Press this button to cancel an operation or exit a menu.
	Menu button Press this button to view the command menu.
	Info button Press this button for detailed information about a displayed item.
	Enter button Press this button to select a displayed item.

6.3 Common LED Indicators and Control Buttons

For complete descriptions of all LED indicators and control buttons see the following table.

Table 13 LED Indicators and Control Buttons







LED Indicator and Control Buttons	Description
	<p>AC On Indicator</p> <p>Illuminates steady green when the main AC power is within acceptable levels. The LED turns off when the level falls below the power-fail threshold and the panel is switched to standby (battery) power.</p>
	<p>CPU Fault Indicator</p> <p>Flashes yellow at the trouble rate when the processor ceases functioning.</p>
	<p>Ground Fault Indicator</p> <p>Flashes yellow at the trouble rate when a ground fault is detected on any field wiring. Clearing the ground fault clears the indication and turns the LED off.</p>
	<p>Battery/Charger Trouble</p> <p>Flashes yellow at the slow flash rate. Clearing the trouble condition clears the indication and turns the LED off.</p>
	<p>ALARM QUEUE Button and Indicator</p> <p>Flashes red when there is an alarm in the queue. The buzzer sounds steady.</p> <p>An alarm can be generated in two ways:</p> <ul style="list-style-type: none"> • When any alarm configured point or input activates. • Pressing the GENERAL ALARM button. <p>Pressing the ALARM QUEUE button allows the user to cycle through and review a list of active alarms from oldest to most recent. Once all alarms in the queue have been reviewed the LED will illuminate steady. Resetting the panel clears the indication and turns the LED off.</p>
	<p>SUPERVISORY QUEUE Button and Indicator</p> <p>Flashes yellow at the fast flash rate when a latching or non-latching circuit is activated. The buzzer sounds at the fast rate.</p> <p>Pressing the SUPERVISORY QUEUE button allows the user to cycle through and review a list of active supervisory alarms from oldest to most recent. Once all alarms in the queue have been reviewed the LED will illuminate steady.</p> <p>If all non-latching supervisory circuits are restored and there are no latching supervisory circuits active, the indication will clear and the LED will turn off.</p> <p>Resetting the panel will clear the activation of any latching supervisory alarms, clears the indication and turns the LED off.</p>

Table 13 LED Indicators and Control Buttons (Continued)



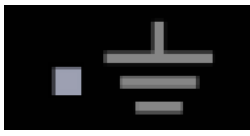

LED Indicator and Control Buttons	Description
	<p>TROUBLE QUEUE Button and Indicator</p> <p>Flashes yellow when any trouble condition is detected on the panel. The buzzer sounds at the slow rate.</p> <p>Pressing the TROUBLE QUEUE button allows the user to cycle through and review a list of active troubles from oldest to most recent. Once all troubles in the queue have been reviewed the LED will illuminate steady.</p> <p>Clearing all trouble conditions clears the indication and turns the LED off.</p>
	<p>BLDG QUEUE (Building Queue) Button and Indicator</p> <p>Flashes yellow at the trouble flash rate when any building condition is detected on the panel. The buzzer sounds at the fast rate.</p> <p>Pressing the BLDG QUEUE button allows the user to cycle through and review a list of active building conditions from oldest to most recent. Once all conditions in the queue have been reviewed the LED will illuminate steady.</p> <p>Clearing all building conditions clears the indication and turns the LED off.</p>
	<p>SYSTEM RESET Button and Indicator</p> <p>The SYSTEM RESET button resets the fire alarm control panel and all circuits. Pressing the SYSTEM RESET button causes a trouble to occur and the LED to illuminate steady yellow. The following events will occur:</p> <ul style="list-style-type: none"> • Resets all latching, trouble conditions. • Resets all initiating circuits. • Resets 4-wire smoke supply and auxiliary power supply. • Turns off all indicating circuits. • Turns off signal silence, ALARM ACKNOWLEDGE and GENERAL ALARM Indicators. • Turns off fire drill. • Stops and resets all timers. • Processes inputs as new events. • Aux disconnect is not affected. • Reset cannot be activated until the signal silence inhibit timer has expired. <p>Resetting the system clears the indication and turns the LED off.</p>
	<p>ALARM ACKNOWLEDGE Button and Indicator - Positive Alarm Sequence</p> <p>LED and Indicator are active only when the panel is configured for PAS. Flashes yellow at the fast flash rate as the auto general alarm timer is timing.</p> <p>If the panel is configured for Positive Alarm Sequence (PAS), activation of the ALARM ACKNOWLEDGE button within 15 seconds of a PAS alarm will delay a common alarm activation for 180 seconds.</p> <p>The expiring of the auto general alarm timer causes the panel to enter general alarm, clears the indication and turns the LED off.</p>

Table 13 LED Indicators and Control Buttons (Continued)







LED Indicator and Control Buttons	Description
	<p>Automatic Alarm Signal Cancel Button and Indicator - Two Stage Operation Only</p> <p>LED and Indicator are active only when the panel is configured for two stage operation. Flashes yellow at the fast flash rate as the auto general alarm timer is running.</p> <p>Illuminates steady yellow by pressing the ALARM ACKNOWLEDGE or SIGNAL SILENCE buttons and cancelling the auto general alarm timer.</p> <p>The expiring of the auto general alarm timer causes the panel to enter general alarm, clears the indication and turns the LED off.</p>
	<p>GENERAL ALARM Button and Indicator</p> <p>LED illuminates steady red when the following occurs:</p> <ul style="list-style-type: none"> • Pressing the GENERAL ALARM button. • Activating a general alarm initiating circuit. • The auto general alarm timer expiring. <p>Resetting the system clears the indication and turns the LED off.</p>
	<p>SIGNAL SILENCE Button and Indicator</p> <p>Flashes yellow at the trouble flash rate when indication circuits are silenced by the following:</p> <ul style="list-style-type: none"> • Pressing the SIGNAL SILENCE button. • The auto signal silence timer. <p>Any subsequent alarms cause the signals to resound, clears the indication and turns the LED off.</p> <p>Pressing the SIGNAL SILENCE button when the panel is in alarm turns on the SIGNAL SILENCE indicator and deactivates any silenceable indicating circuits. Non-silenceable circuits are unaffected. Signals will re-sound upon any subsequent alarm.</p> <p>This button does not function during the following:</p> <ul style="list-style-type: none"> • Any configured signal silence inhibit timer period. • If fire drill has activated the indicating circuits. <p>Additional Two Stage Function</p> <p>If the auto general alarm timer has not expired, this SIGNAL SILENCE button also performs the same function as the ALARM ACK or Automatic Alarm Signal Cancel button.</p>
	<p>BUZZER SILENCE Button and Indicator</p> <p>Flashes yellow at the trouble flash rate when the BUZZER SILENCE button is pressed. Any new alarm, supervisory or trouble events resounds the buzzer and will cause the BUZZER SILENCE LED to turn off.</p>

Table 13 LED Indicators and Control Buttons (Continued)

LED Indicator and Control Buttons	Description
	<p>AUX DISCONNECT Button and Indicator</p> <p>Pressing the AUX DISCONNECT button activates the auxiliary disconnect function. The auxiliary alarm relay is always disconnected with this button. The common alarm relay, the common supervisory relay and all correlated alarm relays may be disconnected as selected through configuration. Pressing the AUX DISCONNECT button also causes the common trouble (TROUBLE QUEUE) LED to illuminate steady, the common trouble relay to send a trouble message and the trouble buzzer to flash at the trouble flash rate. Pressing the AUX DISCONNECT button again de-activates this function and the system will go back to normal.</p>
	<p>LAMP TEST Button and Indicator</p> <p>Pressing the LAMP TEST button illuminates all front panel LEDs on steady in the appropriate color and turns the buzzer on steady. If LAMP TEST is active for more than 10 seconds, TROUBLE QUEUE is activated.</p>
	<p>CO ALARM Button and Indicator</p> <p>Flashes amber when there is a CO alarm in queue. The buzzer sounds steady. Pressing the CO ALARM button allows the user to cycle through and review a list of active alarms from oldest to most recent. Once all alarms in the queue have been reviewed the LED will illuminate steady. Resetting the panel clears the indication and turns the LED off.</p>

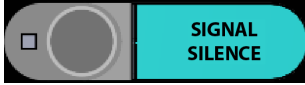
6.3.1 Flash Rates

Fast Flash

120 flashes per minute, 50% duty cycle.

Trouble Flash

20 flashes per minute, 50% duty cycle.

7.0 Wiring

This chapter describes the proper field wiring for the FX-401.

7.1 Wiring Tables

7.1.1 Addressable Loop Wiring Maximums

MGC Devices

- Maximum loop current = 350 mA
- Maximum loop resistance = 40 Ω
- Maximum loop capacitance = 0.5 μF
- Inductance shall not exceed 1 mH

Shield for Analog Loop Wiring: Only twisted pair is recommended, but if shielded twisted pair is used, wire shield at the start and the end of the loop to the terminals marked **S** on the main board or the loop adder board.

Table 14 MGC Devices Addressable Loop Wiring Table

Wire Gauge (AWG)	Maximum Wiring Run to Last Device	
	ft	m
12	10,000	3049
14	7971	2429
16	4980	1518
18	3132	955

7.1.2 RS-485 Wiring to Annunciators and Other Devices

- Use twisted shielded pair
- 300mA power limited
- 22 AWG maximum of 2000 feet
- 20 AWG maximum of 4000 feet

7.1.3 NAC and Auxiliary Power Supply Circuits

Table 15 NAC and Auxiliary Power Circuits Wiring Table

TOTAL SIGNAL LOAD	MAXIMUM WIRING RUN TO LAST DEVICE (ELR)								MAX. LOOP RESISTANCE
	18AWG		16AWG		14AWG		12AWG		
Amperes	ft	m	ft	m	ft	m	ft	m	Ohms
0.06	2350	716	3750	1143	6000	1829	8500	2591	30
0.12	1180	360	1850	567	3000	915	4250	1296	15
0.30	470	143	750	229	1200	366	1900	579	6
0.60	235	71	375	114	600	183	850	259	3
0.90	156	47	250	76	400	122	570	174	2
1.20	118	36	185	56	300	91	425	129	1.5
1.50	94	29	150	46	240	73	343	105	1.2



Note: Main board NAC circuits are rated for of 1.5 amperes each.
Maximum voltage drop should not exceed 1.67 volts.

7.1.4 Input Circuits

If using conventional detectors with an FX-401 FACP, MIX-4042 conventional zone modules must be used. Refer to document LT-1023 for compatible devices.

Table 16 Conventional Zone Module Input Circuit Wiring Table

Wire Gauge	Maximum Wiring Run to Last Device and Back (ELR)	
(AWG)	ft	m
18	3787	1154
16	5952	1814
14	9615	2930



Note: Maximum loop resistance should not exceed 25 Ω .
Maximum wiring run indicates wiring distance out and back to the panel. The resistance across the shorted wire should be less than 25 Ω .

7.2 Wire Routing



Note: All external connections are power limited except for the AC connections to the transformer. Transformer connections must be routed separately from all other external connections using their own conduit.

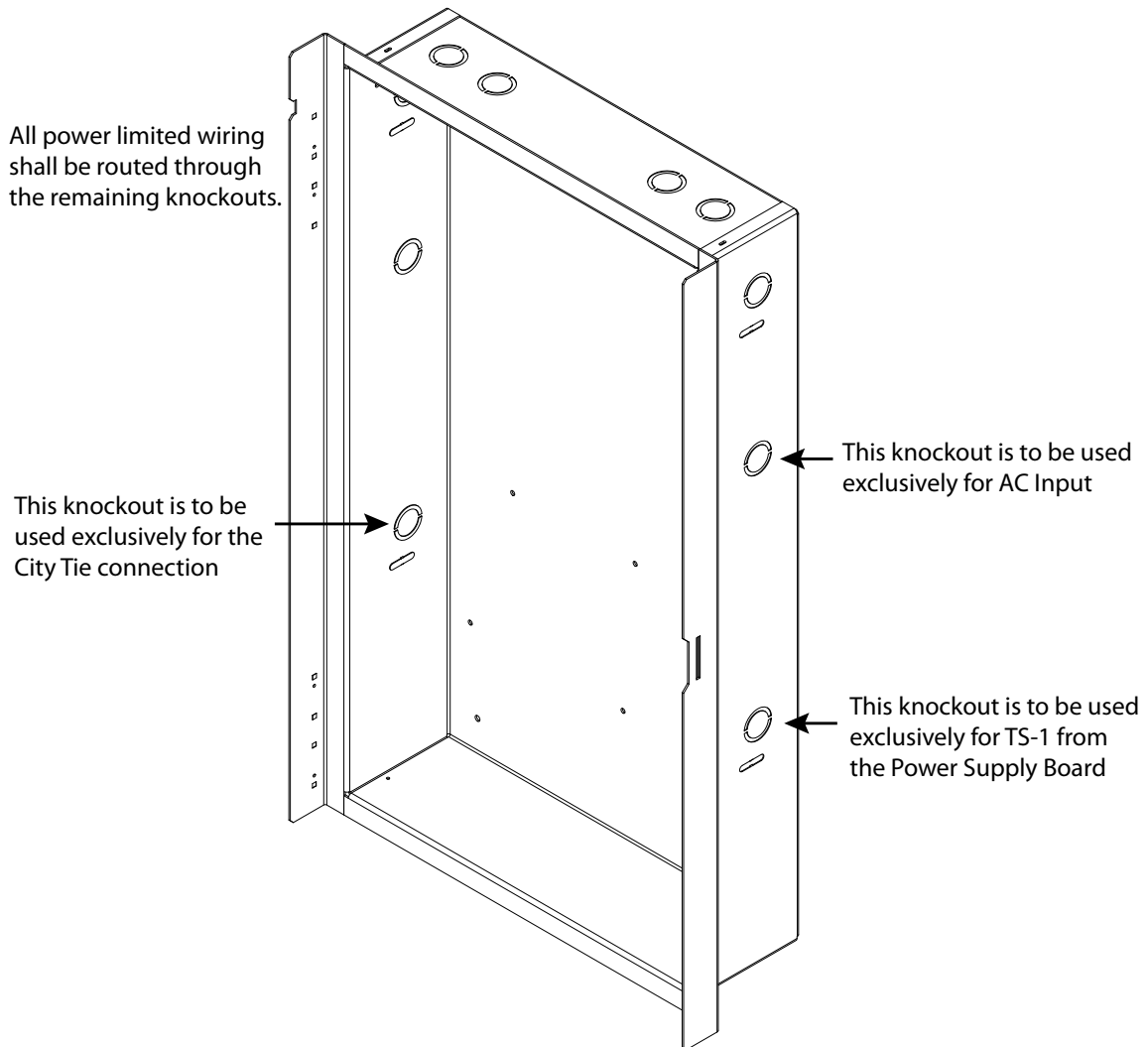

Figure 17 Wire Routing

7.3 Addressable Loop (Signaling Line Circuit) Wiring



Note: When an SLC device is powered by the AUX output, the supervision of the power pathway shall match the SLC pathway performance requirements.

7.3.1 Addressable Loop Wiring - Class B (DCLB)

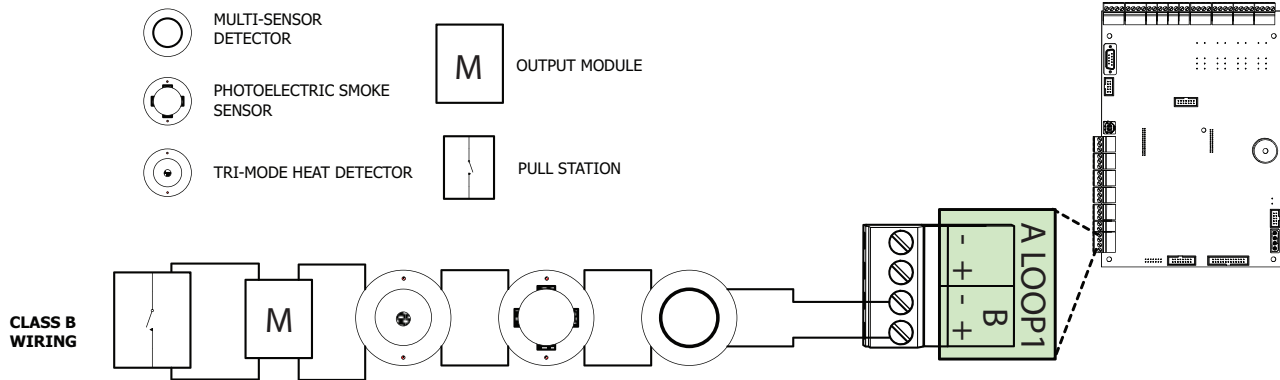

Figure 18 Addressable Loop Wiring - Class B (DCLB)

7.3.2 Addressable Loop Wiring - Class A (DCLA)

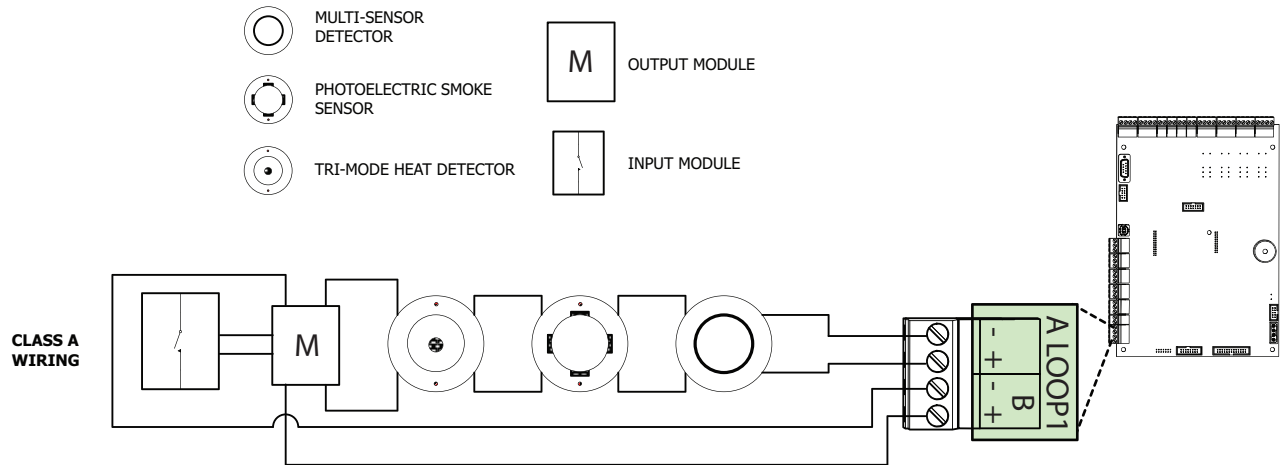

Figure 19 Addressable Loop Wiring - Class A (DCLA)

7.3.3 Addressable Loop Wiring - Class X (DCLC)

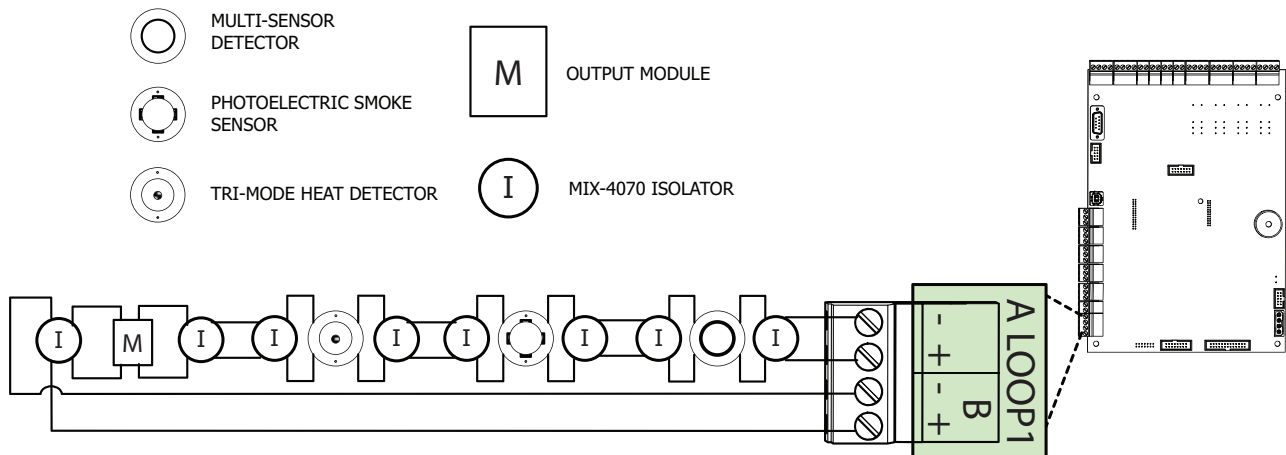

Figure 20 Addressable Loop Wiring - Class X (DCLC)

7.4 NAC Circuit Wiring

The FX-401 supports up to 4 NAC circuits that can be wired as either:

- Class B
- Class A

To supervise each class B NAC circuit, use a 3.9 kΩ end-of-line resistor.

Each NAC circuit provides up to 1.5A, total 6A of current maximum if no auxiliary power is used.

For detailed wiring diagrams see Figure 21 or Figure 22.

7.4.1 NAC Circuit – Class B Wiring

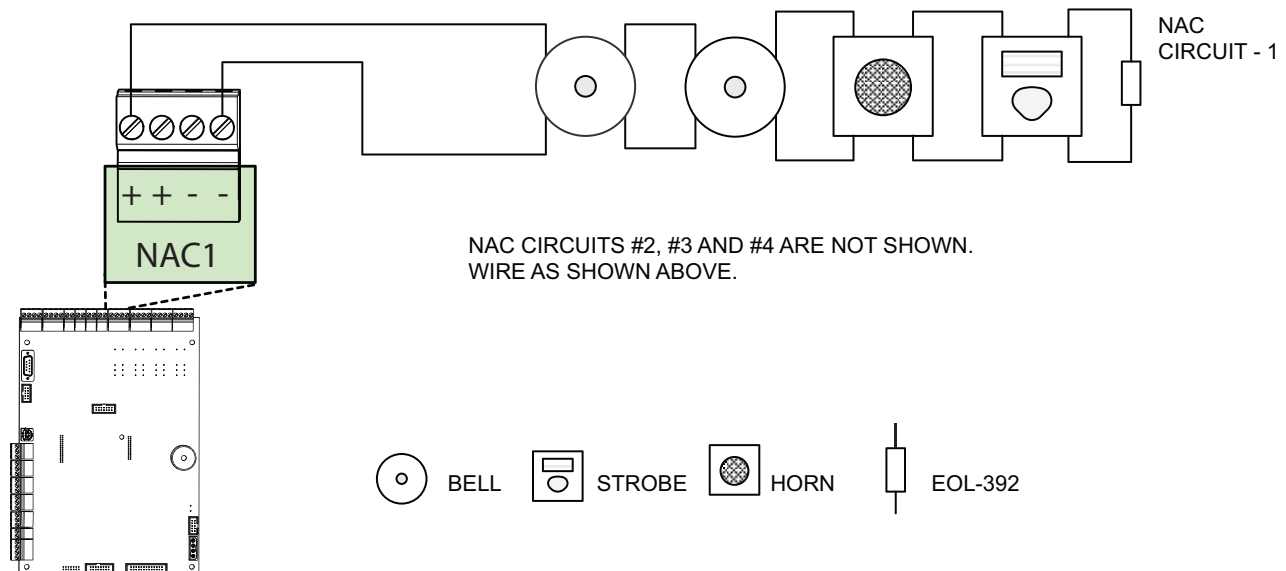

Figure 21 NAC Circuit – Class B Wiring

7.4.2 NAC Circuit – Class A Wiring

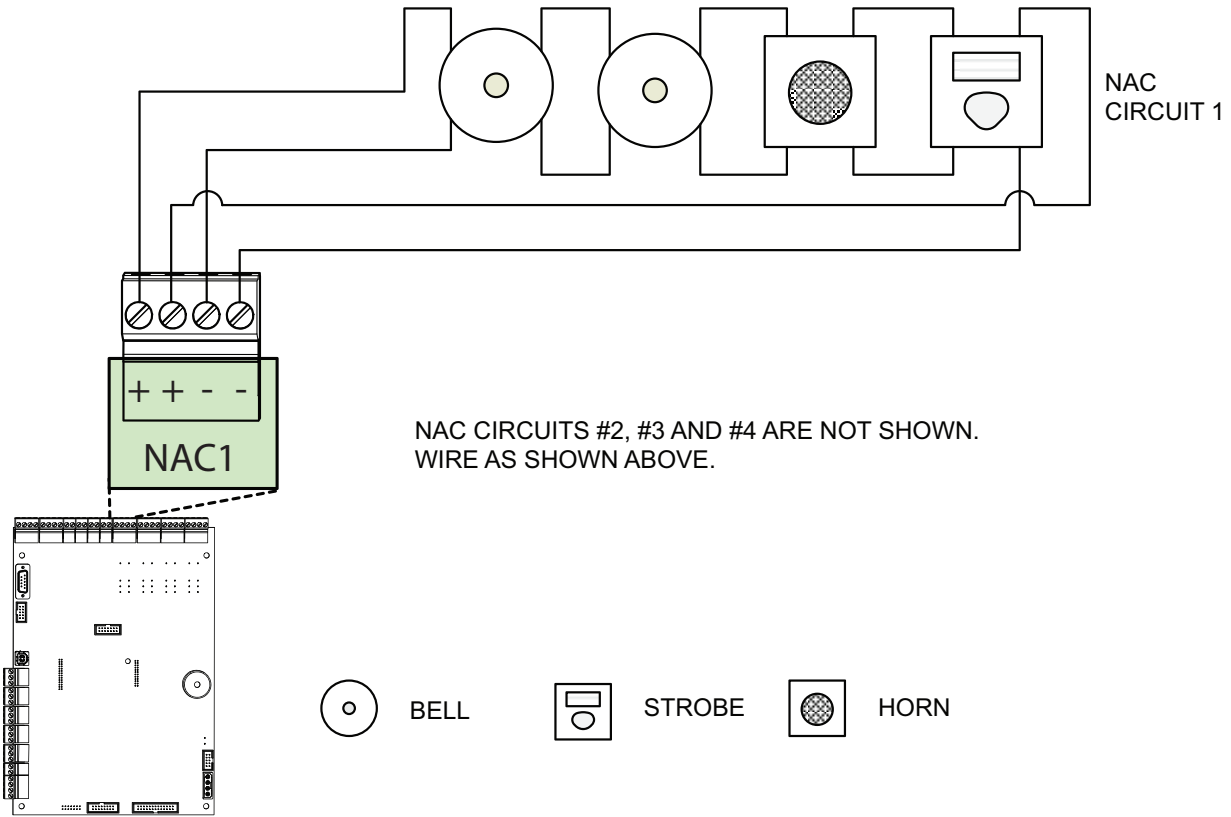

Figure 22 NAC Circuit – Class A Wiring

7.4.3 UL 864 Rev. 10 Addressable Supervised Output Module Wiring

As per UL864 Rev.10 56.4.3, ensure that a single break, ground or wire-to-wire fault on the installation conductors of a signalling circuit for use with addressable notification appliances or modules shall not affect the operation of more than one notification zone.

Exception: Riser conductors installed in accordance with the survivability from attack by fire requirements in National Fire Alarm Code, NFPA 72.

7.4.4 RTI-1 Common Remote Trouble Indicator Wiring

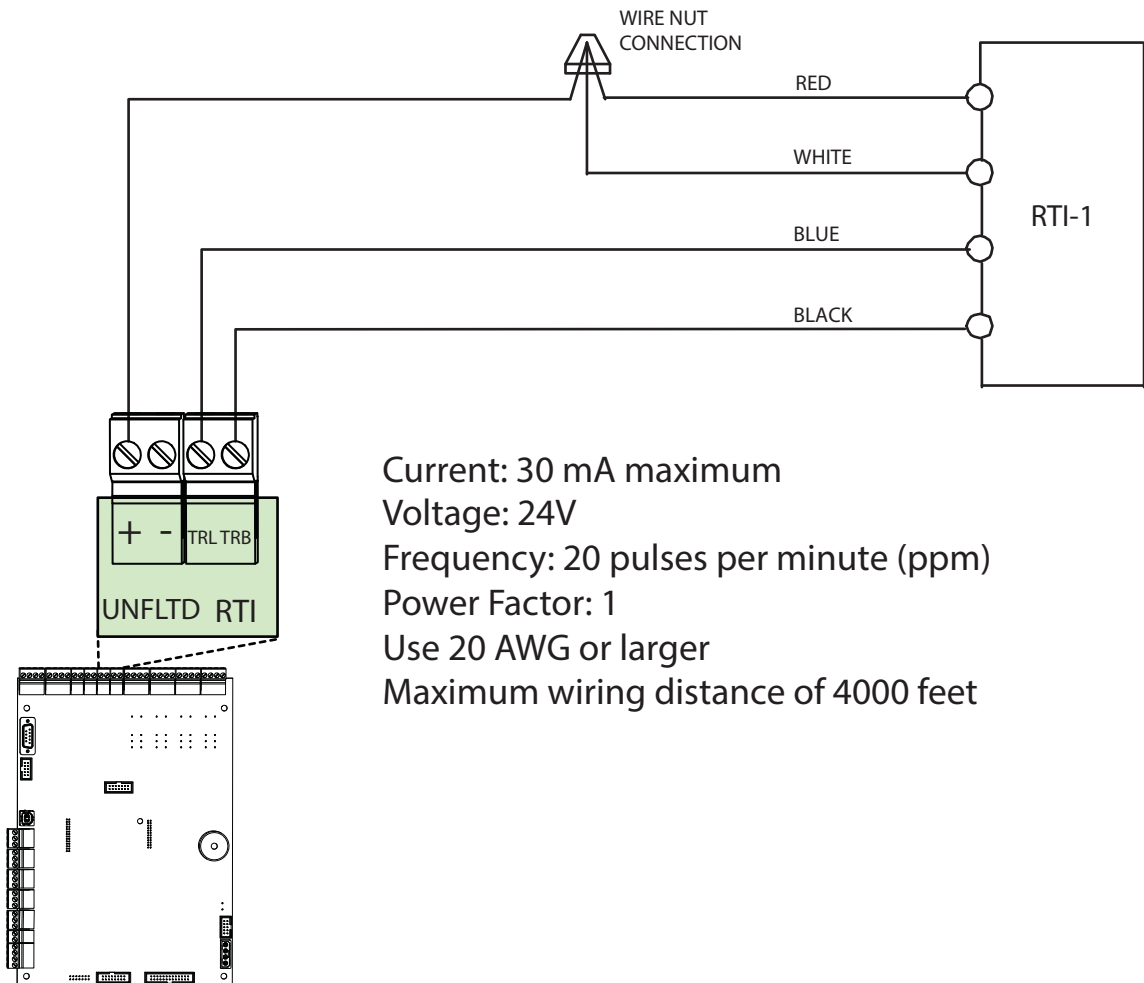
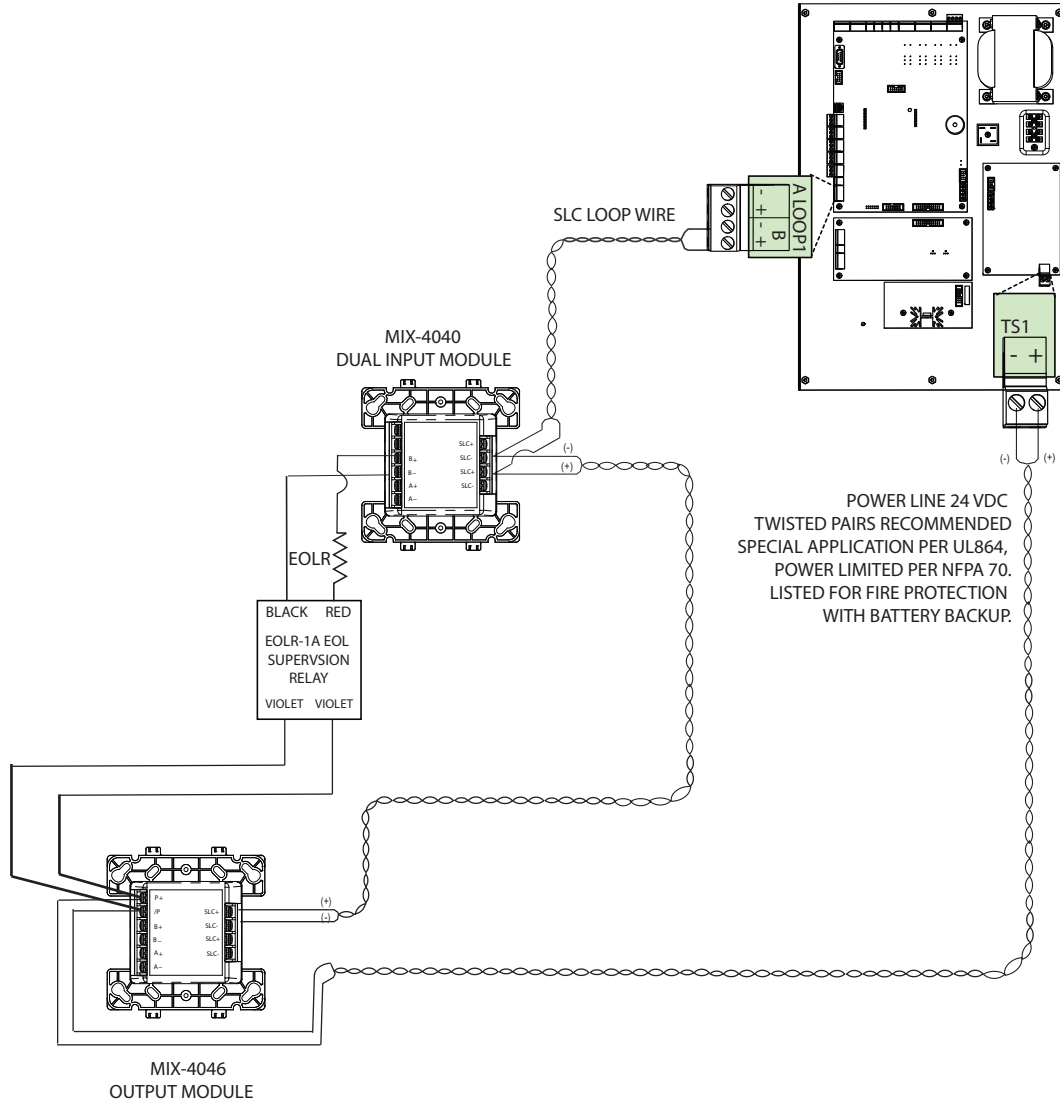

Figure 23 RTI-1 Common Remote Trouble Indicator Wiring

7.5 TS1 SPECIAL APPLICATION Power Source

The TS1 SPECIAL APPLICATION power source is located on the bottom right side of the power board (below the transformer and AC wiring).



ALL WIRING SHOWN IS SUPERVISED AND POWER LIMITED

Figure 24 TS1 SPECIAL APPLICATION Power Source Wiring

7.6 Module and Devices Wiring

7.6.1 Dialer Wiring

Wire the dialer to the public telephone switch and premises telephone as shown in Figure 25. For information on compatible DACR receivers see Appendix A.

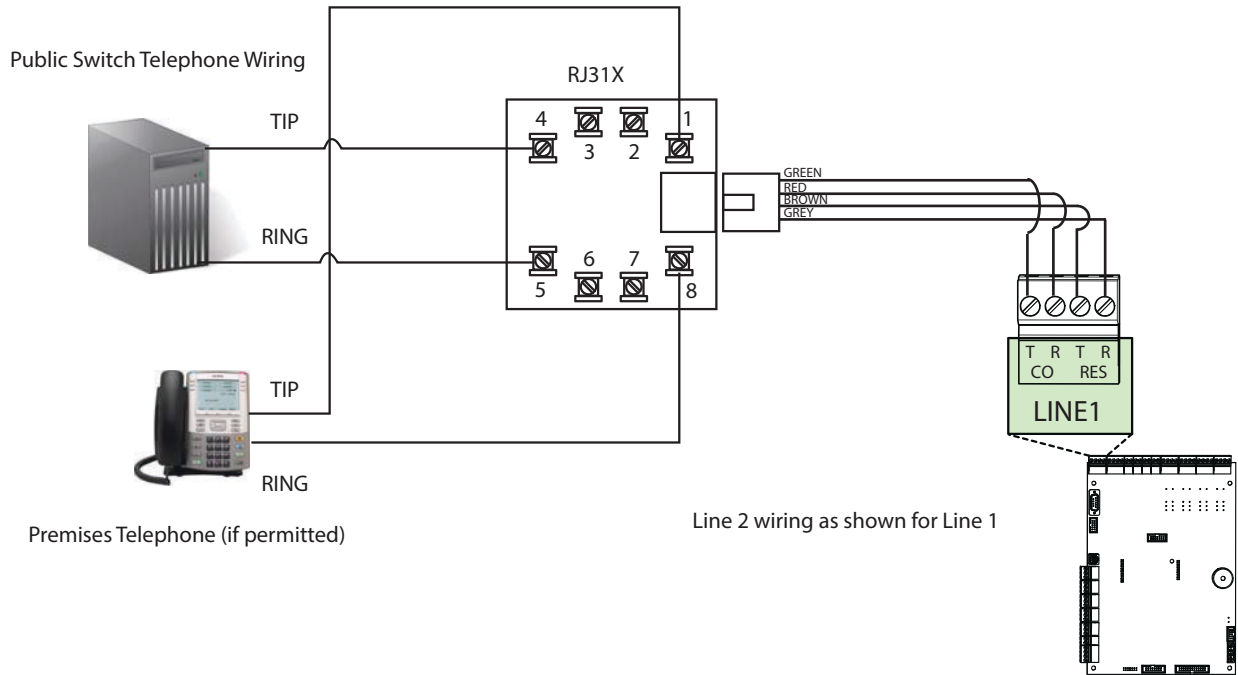

Figure 25 Wiring the Dialer



Caution: To reduce the risk of fire, use only No. 26 AWG or larger telecommunication line cord.

7.6.2 Connecting to a 3G4010 Interface Device in Canada

A typical connection is shown in Figure 26. The PCS-100 passive communications interface board (sold separately) is required.

For information on compatible receivers see Appendix A.

FX-401 - 3G4010 Connection - Typical Diagram

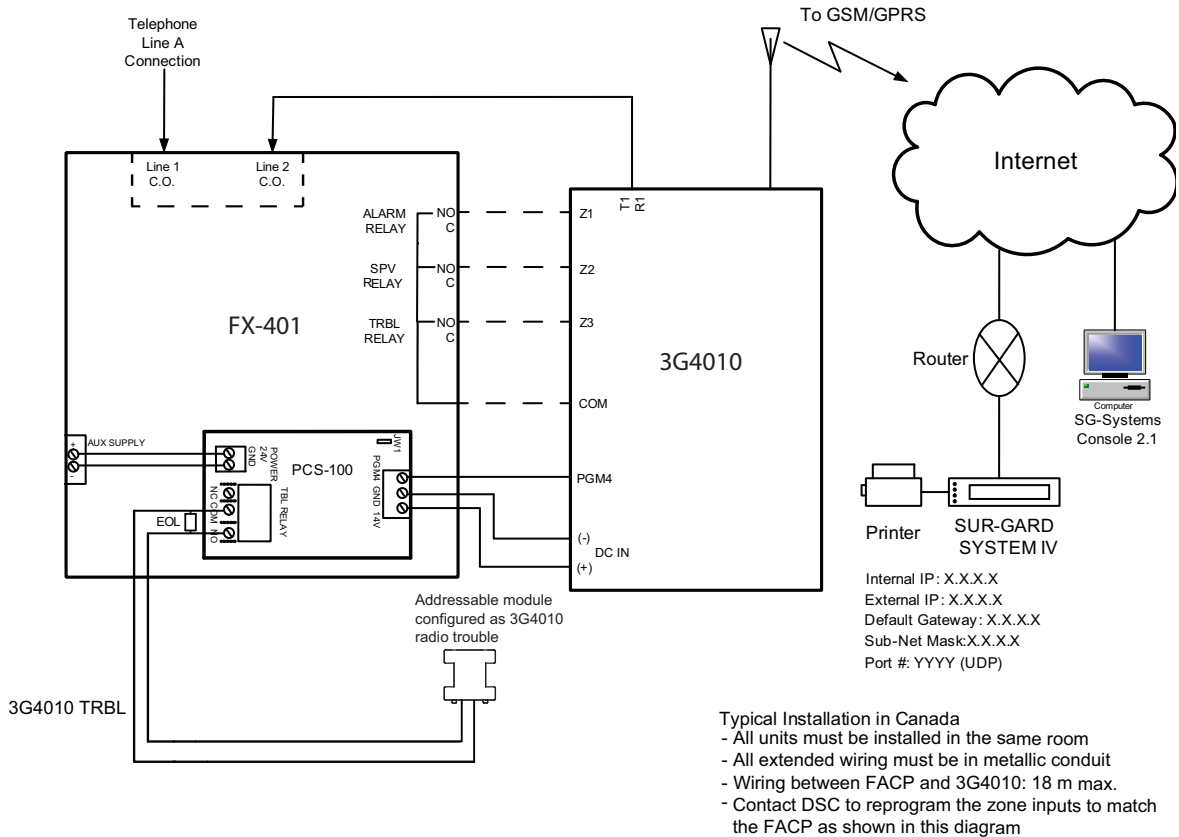

Figure 26 Connecting an FACP to a 3G4010 Interface Device in Canada



Note: The DSC interface device 3G4010 is required if the installation requires ULC S559 certification.

7.6.3 Connecting to a 3G4010CF Interface Device outside Canada

For information on compatible receivers see Appendix A.

A typical connection is shown in Figure 28. The 3G4010CF is powered separately from the PCS-100 and requires 2 DSC RM-2 relays (sold separately). The PCS-100 passive communications interface board (sold separately) is also required.

FX-401 - 3G4010CF Connection - Typical Diagram

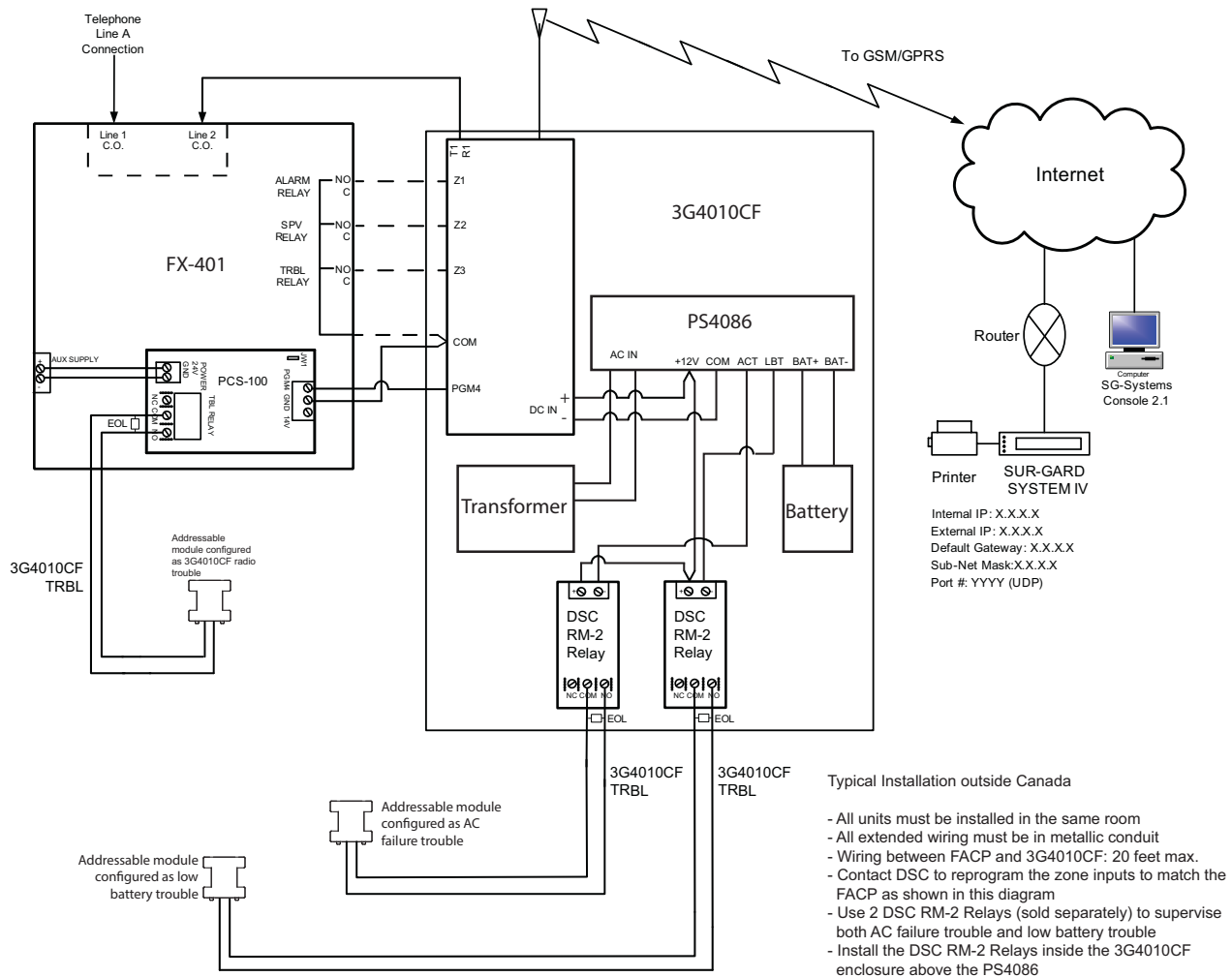

Figure 27 Connecting an FACP to a 3G4010CF Interface Device outside Canada



Note: The DSC interface device 3G4010CF is required if the installation requires UL864 10th edition certification.

7.6.4 Connecting to a NAPCO SLE-LTEV or SLE-LTEA Interface Device outside Canada

For information on compatible receivers see Appendix A.

A typical connection is shown in Figure 28. The SLE-LTEV or SLE-LTEA is powered separately from the PCS-100. The PCS-100 passive communications interface board (sold separately) is also required.

FX-401 - NAPCO STARLINK SLE-LTEV Connection - Typical Diagram

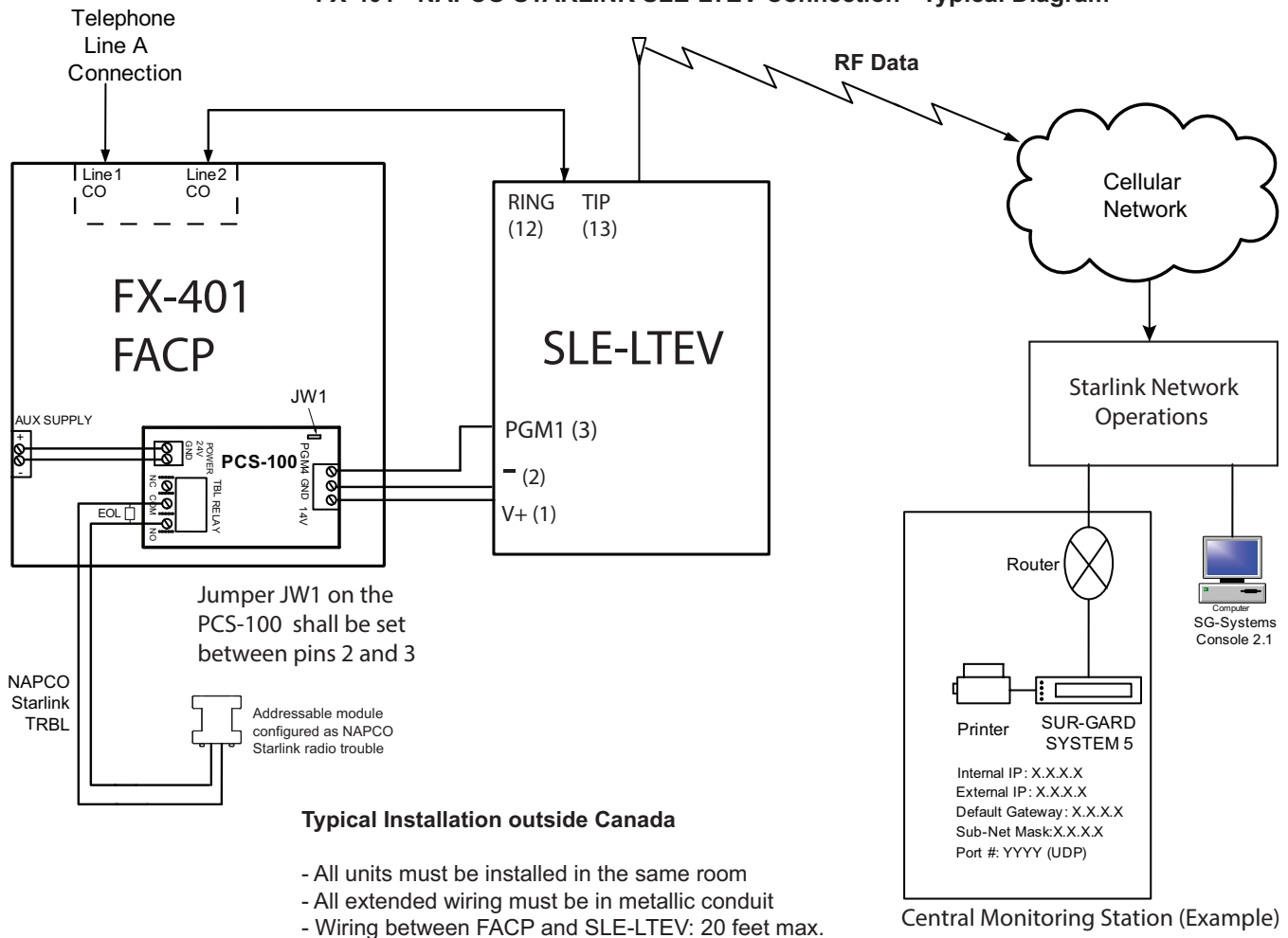

Figure 28 Connecting an FACP to a SLE-LTEV or SLE-LTEA Interface Device outside Canada



Note: The NAPCO interface device SLE-LTEV or SLE-LTEA is required if the installation requires UL864 10th edition certification.

7.6.5 PR-300 Polarity Reversal and City Tie Module Wiring

Wire the PR-300 polarity reversal and city tie module successfully as shown in Figure 29.

- Plug PR-300 ribbon cable P1 into connector P8 on the main fire alarm board.
- Remove jumper plug from JW7 on the main fire alarm board.
- Power limited cable type FPL, FPLR or FPLP must be used.
- For USA installation, the installer must use Atlantic Scientific (Tel: 407-725-8000), Model #24544 Protective Device, or similar UL-Listed QVRG secondary protector, as shown.
- For installations in Canada, the Protective Device is not required but still recommended.

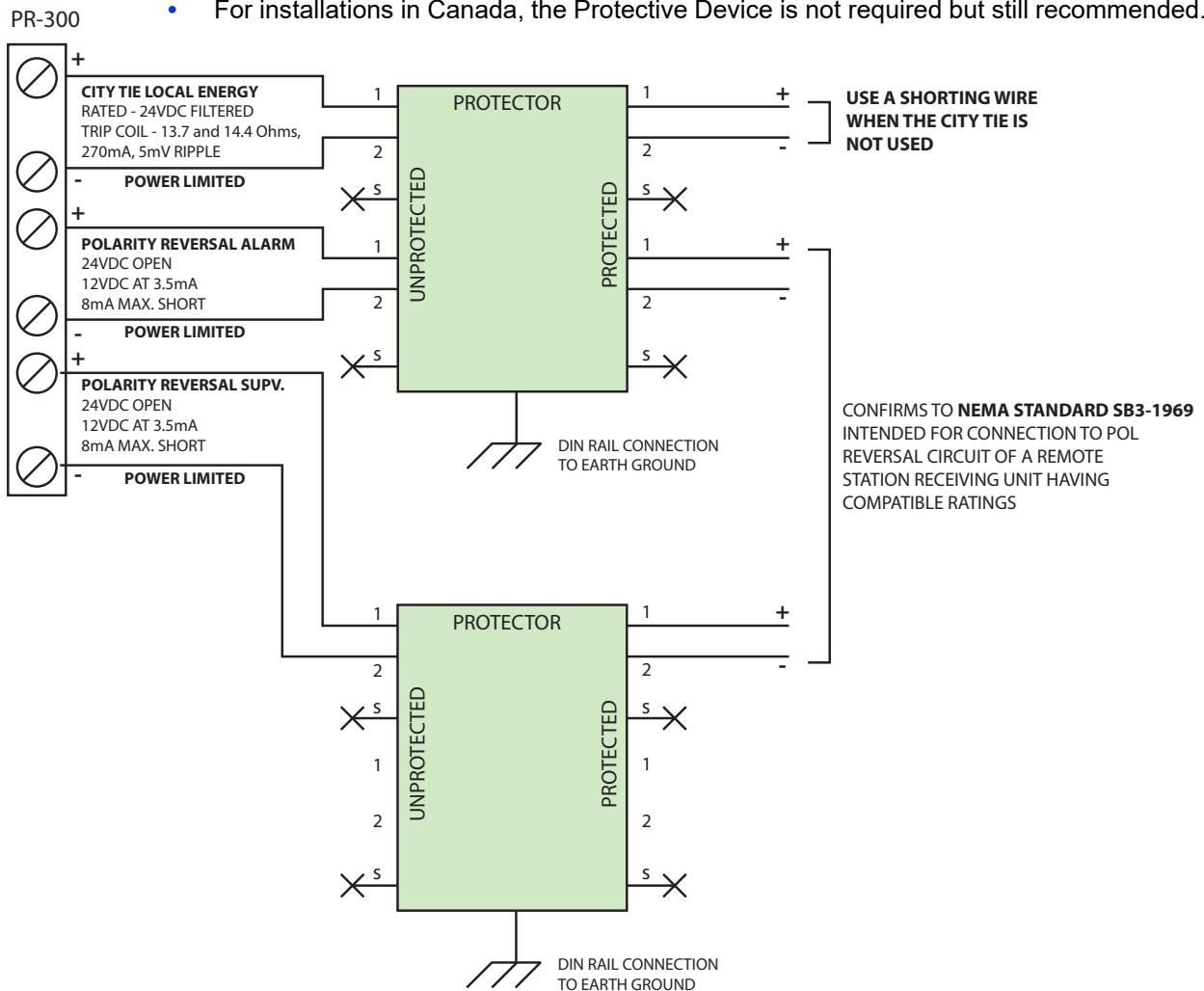

Figure 29 Wiring the PR-300 Polarity Reversal and City Tie Module

7.7 Power Supply Wiring

7.7.1 Main Power Supply Wiring

Wire the power supply as shown in Figure 30 and adhere to the following:

- Ensure that the AC supply is disconnected before wiring the power to the panel.
- Wire the AC power to the AC wiring terminals as shown in Figure 30 using the proper wire gauge with 600 volt insulation and proper over current circuit protection that complies with local codes.

For FX-401 power supply electrical ratings see Table 17 and for specifications see Appendix D.

Table 17 Power Supply Electrical Ratings

Type	Electrical Rating
Electrical Input Rating	120 VAC , 60 Hz, 3.1 A / 240 VAC , 50 Hz, 1.57 A



Attention: The main AC branch circuit connection for the fire alarm control unit must provide a dedicated continuous power without any disconnect devices.

Fire alarm systems must be installed in compliance with local codes and standards and with the Authority Having Jurisdiction (AHJ).

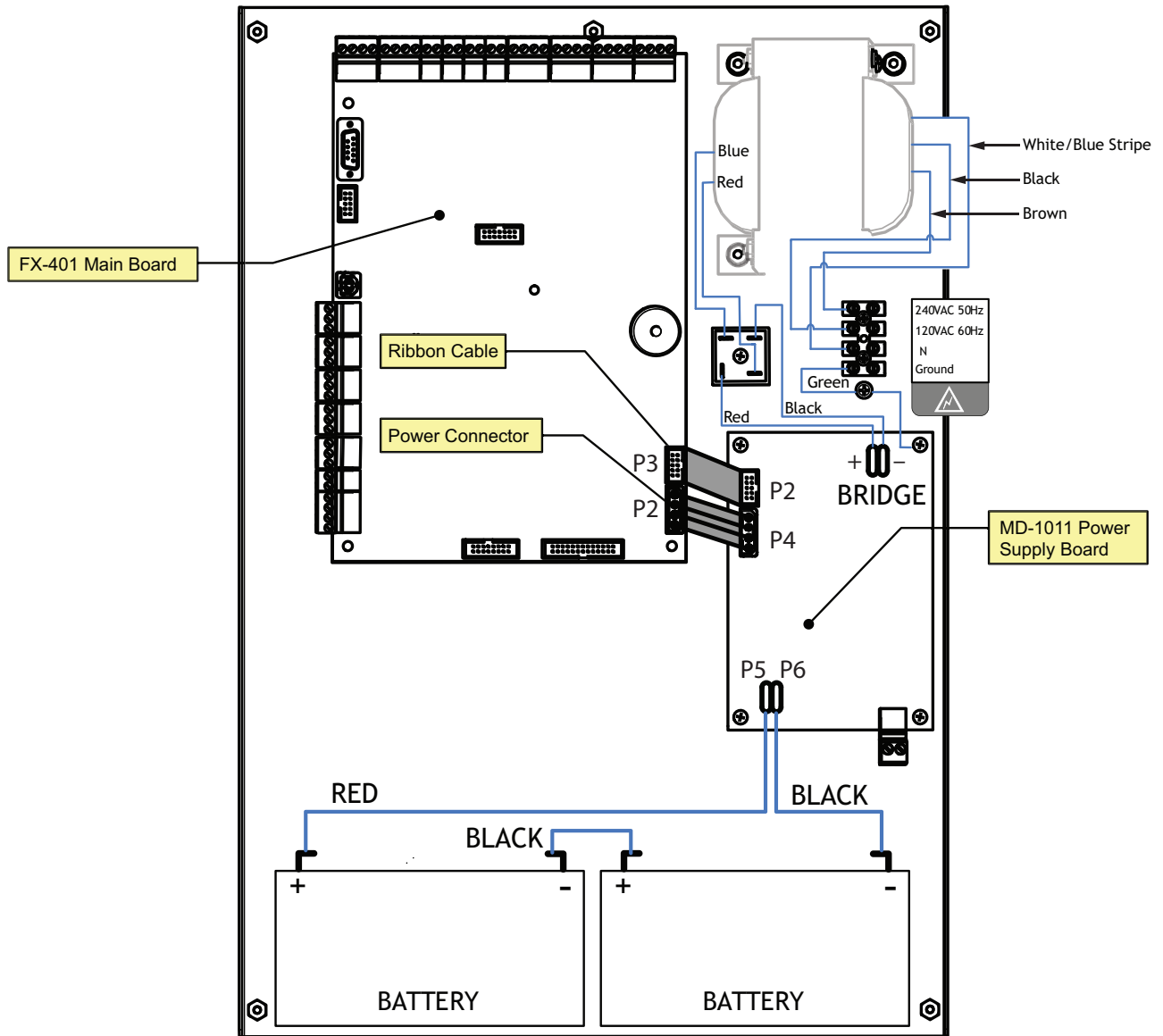

Figure 30 Main Power Supply Wiring and Connections

7.7.2 Supervision (Class B) of Auxiliary Supplies

Aux 2 Resettable Auxiliary Power (supervised, regulated)

The AUX 2 resettable auxiliary power supply is supervised for shorts.

A short will:

- Disconnect the power until the RESET button is pressed.
- Generate a trouble signal.

The circuit must be supervised for opens utilizing the end-of-line relay model EOLR-1(A).

This supply is rated at 24VDC regulated/300mA max/1V voltage drop maximum.

Aux 1 Auxiliary Supply (supervised, regulated)

The AUX 1 auxiliary power is used to power the remote annunciators and smart relay modules.

This filtered circuit is supervised for shorts.

A short will:

- Disconnect the power until the RESET button is pressed.
- Generate a trouble signal.

The circuit must be supervised for opens utilizing the end-of-line relay model EOLR-1(A) as shown in Figure 15.

This supply is rated at 24VDC regulated/500mA max/1V voltage drop maximum.

Unfiltered Supply (unsupervised, unregulated)

This unregulated supply is not supervised. When supervision is required, the circuit must be supervised for opens utilizing the (UL listed - S3705) end-of-line relay model EOLR-1(A). This supply is rated at 24V FWR/1.7A max. If there is a short on this circuit, the auxiliary power does not recover automatically when the short is removed. The main power and the battery must be disconnected, then reconnected and the panel reset to re-establish the auxiliary power supply.

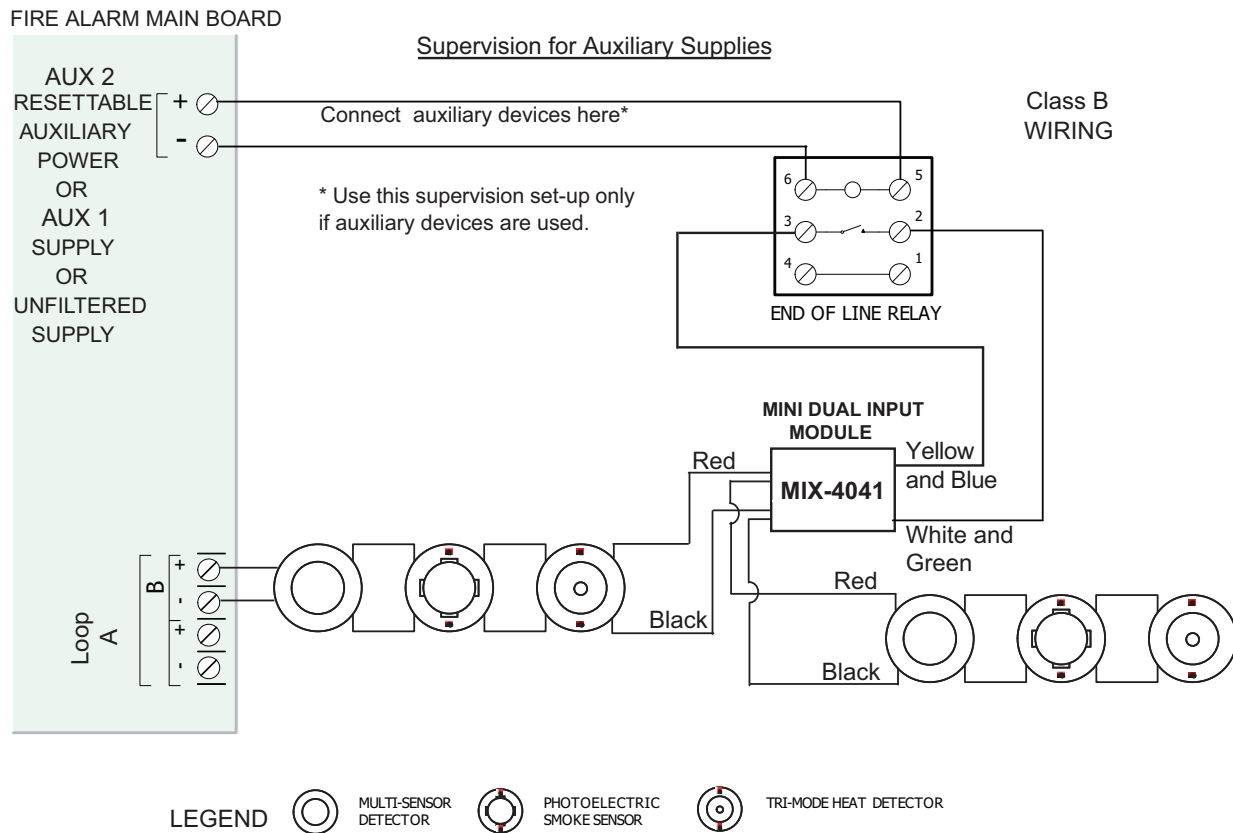

Figure 31 Supervision of Auxiliary Supplies

7.8 Placement of Ferrites for FCC Standard

7.8.1 Ferrite Locations

Two ferrites are required to be mounted on the wires coming from the loop terminals and the auxiliary power terminals.

Refer to picture below, of the FX-401 main fire alarm board.

Ferrite labeled **FER-002** is used to loop Aux 1 and Aux 2 wires if used. The wires coming out of the Aux 1 and Aux 2 terminals (if used) are fed through the ferrite **FER-002** and out (NO LOOPING).

Ferrite labeled **FER-003** is used for Loop 1 wires as shown here. The wires coming out of the SLC (Loop 1) on the main board are fed through the ferrite **FER-003** and looped around once and out the ferrite as shown in this photo.

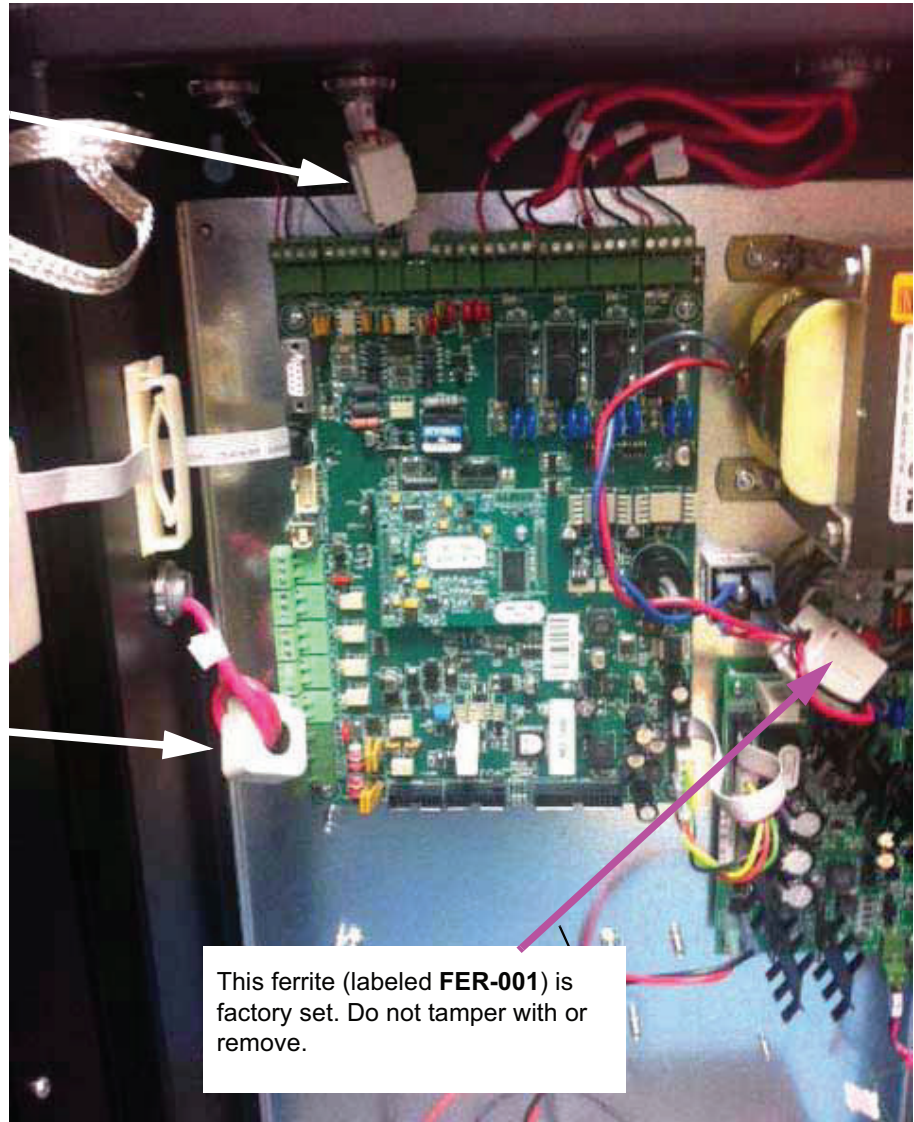

Note: Ferrites must be connected as stated for adherence of FCC rules.

7.8.2 ALC-480 Dual Loop Adder Module

If an ALC-480 dual loop adder module is used with the FX-401, one ferrite is required for each loop. The two ferrites are packed with the ALC-480. Place the wires coming out of Loop 1 through the ferrite and loop around the ferrite once and back out to connect to devices. If using Loop 2, also place the wires coming out of Loop 2 through the second ferrite and loop wires around the ferrite once and back out to connect to devices.

7.9 System Checkout

The following are the recommended steps before and during the powering up of the FX-401.

7.9.1 Before Turning The Power ON

1. To prevent sparking, DO NOT connect the batteries first. Connecting the batteries is only to be done after the system has been powered from the main AC supply.
2. Check all field (external) wiring for opens, shorts, and ground.
3. Check that all interconnection cables are secure, and that all connectors are plugged-in properly.
4. Check all jumpers and switches for proper setting.
5. Check the AC power wiring for proper connection.
6. Check that the chassis is connected to EARTH GROUND (cold water pipe).
7. Close the front cover plate before powering the system from main AC supply.

7.9.2 Power-up Procedure

1. After completing section 7.9.1, power-up the panel. The green **AC ON** LED should illuminate.
2. Since the batteries are not connected, the **Battery Trouble** LED should illuminate, the common trouble (**TROUBLE QUEUE**) LED should flash and the trouble relay (on the main board) will be active.
3. Connect the batteries while observing correct polarity; the red wire is positive (+) and black wire is negative (-).
4. All indicators should extinguish except for normal power **AC ON** green LED.

7.10 Troubleshooting

The following are common methods to solving circuit ground fault, battery and common troubles.

7.10.1 Circuit Trouble

Normally when a circuit trouble occurs, the common trouble (TROUBLE QUEUE) indicator will be illuminated and the common trouble relay will be active. Additionally, the corresponding LED on the main board will be illuminated. This can be viewed by opening the panel and looking the top of the board. To correct the fault, check for open wiring on that particular circuit loop.

7.10.2 Ground Fault

This panel has a common ground fault detector. To correct the fault, check for any external wiring touching the chassis or other earth ground connection.

7.10.3 Battery Trouble

Check for the presence of batteries and their conditions. Low voltage (below 20.4V) will cause a battery trouble. If battery trouble condition persists, replace batteries as soon as possible.

7.10.4 Common Trouble

If only a common trouble is indicated on the main panel and none of those above confirming trouble indicators are on, then check the following for possible fault.

- Any missing interconnection wiring.
- Improperly secured cabling.

Appendix A: Compatible Receivers

The built-in dialer in the FX-401 Fire Alarm Control Panel is compatible with the following Digital Alarm Communicator Receivers (DACR) listed:

Table 18 Compatible DACR Receivers

DACR Receiver	Model Protocols
SurGard MLR2 Multi-Line Receiver (ULC, ULI Approved)	SIA Format Protocol and SIA Contact ID
SurGard SLR Single-Line Receiver (ULC, ULI Approved)	SIA Format Protocol and SIA Contact ID
Osborne-Hoffman Quickalert! II Receiver (ULI Approved)	SIA Format Protocol and SIA Contact ID
Osborne-Hoffman OH-2000 Receiver (ULI Approved)	SIA Format Protocol and SIA Contact ID
Silent Knight Model 9500 Receiver (ULI Approved)	SIA Format Protocol and SIA Contact ID
Radionics Model D6500 Receiver (ULI Approved)	SIA Format Protocol and SIA Contact ID
Radionics Model D6600 Receiver (ULI Approved)	SIA Contact ID
DSC SurGard System III Receiver (ULC, ULI Approved*)	SIA Contact ID
DSC SurGard System IV Receiver (ULC, ULI Approved*)	SIA Contact ID
DSC SurGard System 5 Receiver (ULI Approved**)	SIA Contact ID



Note: *ULI and ULC Approved when used with DSC 3G4010 or 3G4010CF Universal Wireless Alarm Communicator through wireless IP connection.

**ULI Approved when used with NAPCO Starlink SLE-LTEV or SLE-LTEA Universal Wireless Alarm Communicator through wireless IP connection.

Appendix B: Manual Panel Configuration

COMMAND MENU

The command menu is the first menu displayed for command mode. The command menu is divided into four main sub menu categories, the configuration allows full front panel configuration of the system and the operation menu performs certain operations which may not be possible using the common control switches and indicators on the front panel.



Note: See section 6.2.1 for instructions on using the numeric keypad to navigate the menus.

In order to save a change to the configuration, press **Enter**, then press **X** (Cancel) repeatedly until you exit the Configuration menu. The change is saved when the display shows **Config. update**.

```
-- Command menu --  
1 Configuration  
2 Auto config.  
3 Operation  
4 Reset Config  
5 Ack Device Swap  
6 Fire Drill
```

COMMAND MENU/ CONFIGURATION INFORMATION

To see configuration information:

1. Press the **Menu** button.
2. Press the **Info** button.

The first line shows the firmware version and the type of panel. The second and third lines show the job name and version. The fourth line shows the date and time when the panel was configured.

COMMAND MENU/ 1 CONFIGURATION MENU

The configuration menu is divided into the following submenu items.

```
-- Configuration --  
1 Panel config  
2 UDACT config  
3 Time config  
4 AfterHrs cfg.
```

CONFIGURATION MENU/CONFIGURATION/1 PANEL CONFIG

The panel configuration is further sub divided into the following submenus.

```
-- Panel Config --  
1 Features  
2 Address cfg.  
3 Device label  
4 User message  
5 Language
```

PANEL CONFIGURATION/1. FEATURES

The features described are the overall features of the system and their impact is system wide. The default setting in some features is shown as selected.

Panel Configuration/Features/Manual Signal Silence

```
Manual Signal Sil.  
[x] Enabled
```

The manual signal silence option will allow silencing of the signals, from the common control signal silence switch, when they are active.

Panel Configuration/Features/Fire Drill

```
Fire Drill  
[x] Enabled
```

This function is used to enable/disable fire drill operation from the fire common control fire drill switch at the front panel.

Panel Configuration/Features/Waterflow Retard

```
Waterflow retard  
[ ] Enabled
```

If disabled, all the initiating circuits configured as waterflow act as non-verified alarms. If enabled, retard operation is performed for initiating circuits configured as waterflow.

Panel Configuration/Features/Auxiliary disconnect, disconnects alarm and supervisory relay

```
Aux Dis Alm&Sv  
[ ] Enabled
```

If enabled, the auxiliary disconnect operation disconnects the alarm relay and supervisory relay. If disabled, the auxiliary disconnect operation has no effect on the alarm relay and supervisory relay. Default is disabled.

Panel Configuration/Features/Signal silence inhibit timer

```
Sig.sil. inh.  
[x] Disabled  
[ ] 10 sec.  
[ ] 20 sec.  
[ ] 30 sec.  
[ ] 1 min.
```

Select the timer value for the signal silence inhibit timer.

Panel Configuration/Features/Auto signal silence timer

```
Auto sil. tmr  
[x] Disabled  
[ ] 5 min.  
[ ] 10 min.  
[ ] 15 min.  
[ ] 20 min.  
[ ] 30 min.
```

Select timer value for the auto signal silence timer.

Panel Configuration/Features/Alarm transmit silence

```
Alm. xmit. sil.  
[ ] Enabled
```

This feature allows the alarm transmits and auxiliary alarm relay to reset on “SIGNAL SILENCE” rather than the “RESET” switch if enabled. The default is disabled.

Panel Configuration/Features/Power fail timer

```
Pwr fail tmr.  
[x] None  
[ ] 1 hr.  
[ ] 2 hrs.  
[ ] 3 hrs.
```

This feature allows a programmed delay before the AC fail trouble is transmitted by the optional PR-300. (Note: the delay for transmission by the dialer is configured under Dialer Configuration – Item 4 –Time Parameters - AC Loss Delay)

Panel Configuration/Features/Common supervisory relay

```
Com. supv. rly  
[ ] Enabled
```

This feature is used to make the common supervisory relay acts as a common alarm relay if enabled. Default is disabled

Panel Configuration/Features/Signal silence isolator

```
Sig. isolators  
[ ] Enabled
```

This feature makes the system aware that the isolators are present on the main panel powered output circuits if enabled. The default is disabled.

Panel Configuration/Features/Strobe types

```
Strobes type
[ x ] Normal
[   ] Gentex
[   ] System Sensor
[   ] Mircom
[   ] Wheelock
```

Select the strobe manufacturer for synchronous strobes. Synchronous strobes are driven by following a different ON/OFF pattern depending on the manufacturer's specification. Normal means the strobes are not synchronized and when the circuit gets active it is turned ON steady. This feature applies to the main panel powered output circuits, configured as strobes, only.



Note: Once a specific type of strobe is selected, for example Mircom, then only this type of strobe is allowed for the entire system.

Panel Configuration/Features/Evacuation code

```
Evac. Code
[   ] Continuous
[   ] March Time
[ x ] Temporal
[   ] California
```

Select the evacuation code for the 2nd stage in a two stage system and for the 1st stage in a single stage system.

Panel Configuration/Features/Building alert

```
Bldg. alert
[   ] Enabled
```

Alert sounds for building input activation. The default is disabled.

Panel Configuration/Features/Device LED flashing

```
Dev. Flash
[ x ] Enabled
```

This feature allows flashing of the LED on the addressable sensors to flash momentarily, while polling, if enabled. The input and output modules LED always flashes, while polling, regardless of this feature enabled or disabled.

Panel Configuration/Features/Class-A loop

```
Loop ClassA
[   ] Enabled
```

This feature configures all addressable loops as class A if enabled.

Panel Configuration/Features/Auto after hours

```
Auto afthrs.  
[ ] Enabled
```

This feature allows the daytime/nighttime mode to be set automatically if enabled. See “After Hours Config” on page 95.

Panel Configuration/Features/General alarm timer

```
Gen.alm tmr  
[x] Disabled  
[ ] 5 min.  
[ ] 10 min.  
[ ] 15 min.  
[ ] 20 min.  
[ ] 30 min.
```

This feature sets the value for the general alarm timer.

Panel Configuration/Features/Common alarm relay operation

```
Com alm rly op  
[ ] Second stage  
[x] Both stages
```

This feature sets the operation of the common alarm for two stage system.

Panel Configuration/Features/Jurisdiction

```
Jurisdiction  
[ ] ULC  
[x] ULI
```

Default is ULI. This feature selects the ULI or ULC default configuration.

Panel Configuration/Features/Auxiliary Reset Key

```
Aux. Reset Key  
[ ] Enabled
```

This feature is disabled by default. If this feature is enabled, the BUZZER SILENCE switch functions as an Auxiliary Reset switch.

In this case, you can silence the buzzer by pressing any button except the ones listed below:

- GENERAL ALARM
- SIGNAL SILENCE
- Auxiliary Reset (previously BUZZER SILENCE)
- AUX DISCONNECT
- FIRE DRILL
- SYSTEM RESET

Panel Configuration/Features/Pos. Alarm Seq

```
Positive Alarm Seq.  
[ ] Enabled
```

Enable this option to enable the Positive Alarm Sequence feature. It only applies to alarm input devices with the PA flag (F2) set. This feature cannot be enabled if Two Stage Operation is enabled.

Panel Configuration/Features/Dis. Auto Test

```
Disable Auto Test  
[ ] Enabled
```

Enable this option to enable the NFPA device periodical self-test.

Panel Configuration/Features/Subseq. Alarm

```
Subsequent Alarm  
[ ] Enabled
```

Enable this option to enable Subsequent Alarm per Zone. This feature lets you correlate devices to zones, which are represented by the LEDs of the RAX-1048TZDS. If an alarm is activated in a zone, and the signals are silenced, then a subsequent alarm in the same zone does not resound the signals. However, a subsequent alarm in a different zone does resound the signals.

Panel Configuration/Features/CO Priority

```
CO Takes Priority  
[ ] Enabled
```

When disabled, the fire alarm signals take priority over the CO alarm signals. This means that if a fire alarm is active, the indicating circuits sound at the temporal 3 rate even if there is a CO alarm at the same time.

When enabled, the CO alarm signals take priority over the fire alarm signals. This means that if a CO alarm is active, the indicating circuits sound at the temporal 4 rate even if there is a fire alarm at the same time.

Panel Configuration/Features/CO Exp. as Spv

```
CO Expiry as Supv  
[ ] Enabled
```

When enabled, a CO expiry is reported to the receiving station as a CO cell expiry or supervisory message.

When disabled, a CO expiry is reported to the receiving station as a trouble condition.

PANEL CONFIGURATION/2 ADDRESS CFG.

This feature is not used.

PANEL CONFIGURATION/3 DEVICE LABEL

Allows you to edit the device label. Device Address Prompt:

```
Device address  
L_ _ . _
```

User is then prompted for adding a label (skipped if current label).

```
Add label? Y
```

Enter the new label using the keypad. Press the “#” key to move cursor to the left, and press the “*” key to move cursor to the right:

```
Enter new tag...
_____
```

PANEL CONFIGURATION/4 USER MESSAGE

Allows you to change the FACP Front Panel Message, for example “Welcome to Mircom”.

Select either **Normal** or **Off hours**.

```
[x] Normal
[ ] Off hours
```

Enter the new message using the keypad. Press the # key to move cursor to the left, and press the * key to move cursor to the right.

PANEL CONFIGURATION/5 LANGUAGE

Allows you to select the language of the LCD display. English is the default.

```
[x] English
[ ] French
```

COMMAND MENU/CONFIGURATION/2 UDACT CONFIG

This feature allows you to configure the dialer. The dialer can dial out on two phone lines. You must configure an account and specify the line attributes for both.

Configuration/UDACT Config/Account Info

Account #1 ID: 123456	Six digit decimal for the SIA report formats and four digit hexadecimal for Contact ID.
Account #1 Tel: 101	Telephone number.
Account #1 Format: [x] Contact ID [] SIA 300 Baud [] SIA 110 Baud	Choose from Contact ID, SIA300, SIA110.
Account #2 ID: 123456	Six digit decimal for the SIA report formats and four digit hexadecimal for Contact ID.
Account#2 Tel: 101	Telephone number.
Account #2 Format: [x] Contact ID [] SIA 300 Baud [] SIA 110 Baud	Choose from Contact ID, SIA300, and SIA110.

Configuration/UDACT Config/Telephone Line

Line 1 Dialtype Line 2 Dialtype: <input checked="" type="checkbox"/> DTMF Dial <input type="checkbox"/> Pulse Dial	DTMF Dial or Pulse Dial.
Line 1 Dialtone Line 2 Dialtone: <input checked="" type="checkbox"/> Enabled	Enable to wait for dial tone before dialing.
Num Of Retries: 6	Specify the number of retries to make (5-10).

Configuration/UDACT Config/Report Options

Alarm Prio.: <input checked="" type="checkbox"/> Account 1 <input type="checkbox"/> Account 2	Choose one of the two accounts to use to report Alarms.
Trouble Prio.: <input checked="" type="checkbox"/> Account 1 <input type="checkbox"/> Account 2	Choose one of the two accounts to use to report Troubles.
Supv. Priority: <input checked="" type="checkbox"/> Account 1 <input type="checkbox"/> Account 2	Choose one of the two accounts to use to report Supervisory alerts.
Aux Alarm/Supv.: <input type="checkbox"/> Enabled	If enabled, the dialer blocks the alarm and supervisory events from being reported after the auxiliary disconnect button is pressed.
Operation Mode: <input checked="" type="checkbox"/> (U)DACT <input type="checkbox"/> DACT	Choose between DACT and (U)DACT.

Configuration/UDACT Config/Time Parameter

AC-Loss Delay: 0	0-20 hours. Use this menu to delay the reporting of AC loss trouble on the dialer for the programmed time period.
Cellphone Date: 0	<p>To comply with UL 864 10th edition, leave this setting at 0.</p> <p>Set the test report date for the cell phone setup. Leave at 0 if there is no test reporting for a cell phone, or if the phone line is a regular line. Set day of month from 1 to 28 to schedule a test for Line 2 on a certain day of the month.</p> <p>When a cell phone service is employed for the panel, it should only be connected to telephone line #2 CO interface. Also, the dial tone detection feature of Line 2 should be disabled for cell phone application.</p>
Auto-Test Time: 12:30 AM	<p>Use this function to set the time for the automatic test. When this test is performed, the test report is sent to the monitoring station. To comply with UL 864 10th edition, this test must be performed at least once every 6 hours.</p> <p>The Auto test time can be configured to:</p> <p>12:00 a.m. to 5:59 a.m.: test every 24 hours</p> <p>6:00 a.m. to 11:59 a.m.: test every 6 hours</p> <p>12:00 p.m. to 23:59 p.m.: test every 12 hours</p> <p>If the Cellphone Date is 0, then the test alternates between Line 1 and Line 2.</p>

Configuration/UDACT Config/Enable/Disable

Enabled

Uncheck this box to disable the dialer. The dialer is enabled by default.

Configuration/UDACT Config/Ring Detect

Disabled

1

2

3

4

5

6

7

8

Specify the number of rings when dialing in to configure. Warning: if disabled, the next dial in session will not be able to connect.

COMMAND MENU/CONFIGURATION/3 TIME CONFIG

Daylight Save: [x] Enabled	Enable this option to enable automatic change to and from daylight saving time.
Compensation: Seconds:00	Specify the number of seconds (signed) to be applied daily to the panel clock. The range is -15 to 15.

COMMAND MENU/CONFIGURATION/4 AFTER HOURS CONFIG

```
Afthrs. config.  
1 Set daytime  
2 Set weekends
```

This feature allows you to change start and end time of daytime and weekends.



Note: Press the up (also 2) and down (also 8) keys to adjust the values, and the left (also 4) and right (also 6) keys to move between values.

The start time must be earlier than the end time, or you will receive a prompt stating "Wrong time settings."

To set daytime:

1. Select **1 Set daytime** and press Enter.
2. Choose the start time.

```
day time start  
Time: 08:59 AM
```

3. Choose the end time.

```
day time end  
Time: 06:00 PM
```

To set weekends:

4. Select **2 Set weekends** and press Enter.
5. Choose the start time.

```
Weekend start  
Time: 06:00 PM
```

6. Choose the end time.

```
Weekend end  
Time: 08:59 AM
```

COMMAND MENU/ 2 AUTO CONFIG



Attention: Use the MGC-400 Configurator, not the FX-401 Auto Config feature, to program the INX-10A.

The Auto Config feature detects new devices and adds them to the job. Use Auto Config to configure the panel for the first time, or to add new devices to an existing job.

If there is no current configuration, Auto Config detects the devices and correlates every device to all the outputs.

If there is a current configuration, Auto Config detects any new devices, and correlates the new devices to all the outputs. It does not change correlations for existing devices.



Notes: After performing Auto Config, you must finish setting up the job in the Configurator software, for example, assigning tags and creating custom correlations.

1. Wire the MIX-4000 devices to the panel and power up the panel (as described in section 7.9).
2. On the display, select **2. Auto Config**.
3. Enter the level 2 passcode. The default level 2 passcode is **2222**.

```
Detecting Devices
      1%
Do you want to exit
This detection ? Y
```

4. Wait for the system to finish detecting devices. Press **Enter** if you want to stop the process.

When the system has finished detecting devices, it displays the number of devices it found.
5. Press **Enter** to create a new configuration with these devices. All input devices will be assigned the Alarm process type.

```
003 new device(s)
found.
Add with default
programming? Y
```

The system displays a warning that you must check the system at the end of this process.

6. Press **Enter**.

```
WARNING: System
must be thoroughly
rechecked when done.
Continue? Y
```

Wait for the system to be programmed.

```
- Auto Programming -  
  in progress
```

7. If there are any **dual input modules** (DIP) in the job, the system asks if they should be configured as class A. Press up or down (2 and 8 on the keypad) to select **N** or **Y** for each dual input module, then press Enter. If you select **N**, the module will be configured as class B.

If the dual input module is a manual station, select **class A** for single stage and **class B** for two stage.

```
Is this DIP L1.002  
configured for  
Class A ? N
```

8. On the next screen, a message says that auto-correlations will be applied. This means that all inputs will be correlated to all notification appliance circuits and output modules.

```
Auto-correlation  
be applied to  
the changes !
```

The system updates the configuration, then displays the system menu.

```
Config. update...
```

9. Press the Exit button to exit the menu and return to the main display message.
10. Connect the MGC-400 Configurator to the panel and get the job.
11. Carefully review the job.
12. Finish setting up the job. For example, assign tags and create custom correlations.
13. Send the job to the panel.



Attention: The Auto Config feature assigns the Alarm process type to all input devices, and correlates all input devices to all notification appliance circuits and output modules. Relay modules are not correlated and require further programming. The Auto Config feature does not create tags, and keeps the panel configuration options at the default. You must customize the job so that it works properly according to the site's requirements.

COMMAND MENU/ 3 OPERATION

See section 5.11.

COMMAND MENU/ 4 RESET CONFIG



Attention: This option erases your current configuration and resets all devices to default.

This option resets all devices on the SLC to the Alarm process type, removes the tags, and resets the correlations to the default (all inputs correlated to all outputs).

1. On the display, select **4. Reset Config**.
2. Press **Enter**.

```
Reset configuration!  
Yes ? Y
```

3. Press **Enter** to reset all devices to default.

```
Reset configuration!  
to match  
1 loop(s) and  
003 device(s) ?Y
```

Wait for the system to be reset.

```
- Auto Programming -  
in progress
```

4. If there are any dual input modules in the job, the system asks if they should be configured as Class A. Press up or down to select N or Y for each dual input module.

```
Is this DIP L1.002  
configured for  
Class A ? Y
```

5. On the next screen, a message says that auto-correlations will be applied. This means that all inputs will be correlated to all outputs.

```
Auto-correlation  
be applied to  
the changes !
```

The system updates the configuration.

```
Config. update...
```

6. Press the Exit button to exit the menu and return to the main display message.
7. Connect the MGC-400 Configurator to the panel and get the job.
8. Finish setting up the job. For example, assign tags and create custom correlations.
9. Send the job to the panel.

COMMAND MENU/ 5 ACK DEVICE SWAP

If you replace a MIX-4010(-ISO) detector with a MIX-4011(-ISO), or a MIX-4020(-ISO) with a MIX-4021(-ISO), you can use the ACK Device Swap feature to recognize the new device automatically.

i

Note: Both the old and new device must have the same address.

1. Remove the old device from the base and install the new device in its place.

The panel indicates "wrong device type".

i

Note: If the panel indicates "missing device", this means that the old and new devices have different addresses.

2. Press the **Menu** button.
3. Scroll down to **Ack Device Swap** and press **Enter**.

```
Command Menu
 3 Operation
 4 Reset Config
 5 Ack Device Swap
```

4. Enter the passcode.
5. When the warning below appears, press **Enter**.

You will have 6 seconds to acknowledge the device swap.

```
-----Warning-----
Will you acknowledge
the device swap and
clear logs? Y
```

6. If a device swap is detected, the display will show the devices swapped. Press **Enter** to confirm the swap.

You will have 30 seconds to confirm the swap.

```
0 4010,      0 4020,  
1 4011,      1 4021  
were swapped with  
equivalent. Yes?
```

If no device swap is detected, the program will exit, and the system will return to the Command Menu.

```
No Devices Swapped  
Exit!
```

Once the device swap is confirmed, the loops will be initialized and the system will return to normal operation.

COMMAND MENU/ 6 FIRE DRILL

The fire drill activates all programmed and nondisconnected indicating circuits. It does not transmit any alarms via the city tie, or common alarm relay.

Fire drill may be programmed to operate specific NAC circuits. Fire drill is cancelled if the panel goes into a real alarm.

To conduct a fire drill:

1. Press the **Menu** button.
2. Scroll down to **Fire Drill** and press **Enter**.
3. When the warning below appears, press 2 or 8 to select **Y** (Yes) or **N** (No). Once selected, press **Enter**.

```
-----Warning-----  
Do you want to conduct  
a Fire Drill? Y
```

Selecting **N** will redirect you to the home screen.
Selecting **Y** will activate the fire drill.

```
Feb 25 2025 06:09:41  
Fire drill  
activated  
  
B0001/0001
```

To end the fire drill:

1. Press the **Menu** button.
2. Scroll down to **Fire Drill** and press **Enter**.
3. When the warning below appears, press 2 or 8 to select **Y** (Yes) or **N** (No). Once selected, press **Enter**.

```
-----Warning-----  
Do you want to end the  
Fire Drill? Y
```

Selecting **N** will redirect you to the home screen.
Selecting **Y** will end the fire drill.

Appendix C: Reporting

Ademco Contact-ID FX-400 Series Event Codes

Table 19 Contact-ID Event Codes

Event Description	Event Family	Qualifier	Code	Group #	Contact #
Phone Line #1 trouble detected	Trouble	New event	1 351	00	000
Phone Line #2 trouble detected	Trouble	New event	1 352	00	000
Phone Line #1 trouble restored	Trouble	Restore	3 351	00	000
Phone Line #2 trouble restored	Trouble	Restore	3 352	00	000
Failure to report to an Account	Trouble	New event	1 354	Acct #	Acct #
Report to an Account successful	Trouble	Restore	3 354	Acct #	Acct #
RS-485 Communication Trouble	Trouble	New event	1 350	00	485
Periodic (24 hr) Test Event (NORMAL)	Test	New event	1 602	00	000
Periodic (24 hr) Test Event (OFF NORMAL)	Test	New event	1 608	00	000
Manually initiated dialer test	Test	New event	1 601	00	000
Zone Fire Alarm	Alarm	New event	1 110	00	NNN
Zone Fire Alarm restored	Alarm	Restore	3 110	00	NNN
Zone Trouble detected/CO Trouble Open	Trouble	New event	1 300	00	NNN
Zone Trouble restored /CO Trouble Open restored	Trouble	Restore	3 300	00	NNN
Zone Supervisory condition	Supervisory	New event	1 200	00	NNN
Zone Supervisory restored	Supervisory	Restore	3 200	00	NNN
Water flow	Alarm	New event	1 113	00	NNN
Water flow restored	Alarm	Restore	3 113	00	NNN
Indicating Zone Trouble	Trouble	New event	1 320	00	NNN
Indicating Zone Trouble restored	Trouble	Restore	3 320	00	NNN
General Alarm	Alarm	New event	1 140	00	NNN
General Alarm restored	Alarm	Restore	3 140	00	NNN
AC power lost	Trouble	New event	1 301	00	000
AC power restored	Trouble	Restore	3 301	00	000
Battery Low	Trouble	New event	1 302	00	000
Battery Low restored	Trouble	Restore	3 302	00	000
Ground Fault	Trouble	New event	1 310	00	000

Table 19 Contact-ID Event Codes (Continued)

Event Description	Event Family	Qualifier	Code	Group #	Contact #
Ground Fault restored	Trouble	Restore	3 310	00	000
CO Alarm and Supervisory	Alarm	New event	1 162	00	NNN
CO Alarm and Supervisory restored	Alarm	Restore	3 162	00	NNN
CO Cell Expiry	Supervisory	New event	1 394	00	NNN
CO Cell Expiry restored	Supervisory	Restore	3 394	00	NNN

Security Industries Association SIA Format Protocol FX-400 Series Event Codes

SIA Format Protocol does not define indicating zone troubles, but lists it as Untyped Zone Trouble/Restore.

Table 20 SIA-DCS Event Codes

Event Description	Event Family	Qualifier	SIA Event Code	Parameter
Phone Line #1 trouble detected	Trouble	New event	LT	001
Phone Line #2 trouble detected	Trouble	New event	LT	002
Phone Line #1 trouble restored	Trouble	Restore	LR	001
Phone Line #2 trouble restored	Trouble	Restore	LR	002
Failure to report to an Account	Trouble	New event	YC	Acct #
Report to an Account successful	Trouble	Restore	YK	Acct #
RS485 Communication Trouble	Trouble	New event	YS	485
Periodic (24 hr) Test Event (Normal)	Test	New event	RP	000
Periodic (24 hr) Test Event (Off-normal)	Test	New event	RY	000
Manually initiated dialer test	Test	New event	RX	000
Zone Fire Alarm	Alarm	New event	FA	NNN
Zone Fire Alarm restored	Alarm	Restore	FH	NNN
Zone Trouble detected	Trouble	New event	FT	NNN
Zone Trouble restored	Trouble	Restore	FJ	NNN
Zone Supervisory condition	Supervisory	New event	FS	NNN
Zone Supervisory restored	Supervisory	Restore	FR	NNN
Water flow alarm	Alarm	New event	WA	NNN
Water flow alarm restored	Alarm	Restore	WH	NNN
General Alarm	Alarm	New event	QA	NNN
General Alarm restored	Alarm	Restore	QH	NNN

Table 20 SIA-DCS Event Codes (Continued)

Event Description	Event Family	Qualifier	SIA Event Code	Parameter
Indicating Zone Trouble (*)	Trouble	New event	UT	NNN
Indicating Zone Trouble restored (*)	Trouble	Restore	UR	NNN
AC power lost	Trouble	New event	AT	000
AC power restored	Trouble	Restore	AR	000
Battery Low	Trouble	New event	YT	000
Battery Low restored	Trouble	Restore	YR	000
Ground Fault	Trouble	New event	YP	000
Ground Fault restored	Trouble	Restore	YQ	000
CO Alarm	Alarm	New event	GA	NNN
CO Alarm restored	Alarm	Restore	GH	NNN
CO Supervisory/CO Cell expiry	Supervisory	New event	GS	NNN
CO Supervisory restored/CO Cell expiry restored	Supervisory	Restore	GR	NNN
CO Trouble detected	Trouble	New event	GT	NNN
CO Trouble restored	Trouble	Restore	GJ	NNN

Appendix D: Specifications

FX-401 Fire Alarm Control Panel

Table 21 lists specifications for the FX-401 panel:

Table 21 FX-401 Specifications

FX-401 Fire Alarm Control Panel		
General	Digital signal processor based design, fully configurable from front panel with password protection.	
Electrical ratings	AC line voltage	120VAC 60Hz/240VAC 50Hz, 10A slow blow fuse on secondary of transformer
	Power supply rating	29VAC 10A maximum (secondary of transformer)
		120VAC 60Hz 3.1 amp (maximum primary of transformer) 240VAC 50Hz 1.57amp (maximum primary of transformer) Total load not to exceed 10A at 24VDC
Battery	Type	24VDC Gel Cell/Sealed lead acid – 10Ah to 42Ah
	Charging capability	10Ah to 42Ah
	Charging current	3A maximum
	Protection	20A slow blow micro fuse built into WX-058 battery cable, field replaceable
	Standby current rating at full load	1.25A
Addressable loops	MGC Protocol with one or three loops with 240 addressable sensors and addressable modules per loop. Maximum loop resistance depends on number of devices and device type. For a complete list of compatible devices see LT-1023 Compatible Devices Guide. Power Limited / 24V DC / 350mA alarm maximum / 0.5 μ F Power Limited / 24V DC / 280mA normal standby maximum / 0.5 μ F	
NAC circuits	4 supervised class B NAC circuits, configured as strobes or audibles. Terminals are labelled as “NAC 1”, “NAC 2”, “NAC 3” and “NAC 4”.	
	Rating	Power limited / regulated 24V FWR / 1.5A @ 49°C per circuit
	Max power allowed	Total 6.0A 1.5A per circuit
Aux supply 1	Power limited / 24VDC regulated / 500mA max	
Aux supply 2	Resettable Power limited / 24VDC regulated / 300mA max Use this supply for MIX-4042, MIX-4046, MIX-4003-R, MIX-4003-S, MIX-4003-LF	

Table 21 FX-401 Specifications (Continued)

FX-401 Fire Alarm Control Panel		
Unfiltered supply	Power limited / 24V FWR special application / 1.7A max at 49°C List of Compatible Devices: RAM-1032TZDS, RAM-3500-LCD, RAX-LCD-LITE	
Auxiliary relays	Common Alarm/Supv./Trouble/Auxiliary Alarm	Must be connected to a listed power limited source of supply, Form C/28VDC/1A max.
TS1 power supply board	24VDC 1.4A power limited special application. 24.9 - 28.2 VDC recorded range for compatibility. Supervised by EOLR-1A end-of-line relay.	
RS-485 port	For remote annunciators. Terminals are labelled RS-485	
Ground fault impedance	10 kΩ	
Open circuit fault	100 kΩ	
Short circuit fault	0 Ω	
Applicable standards	NFPA 70, 72, CAN/ULC-S559, UL-864, ULC S524, CAN/ULC-S527 and ULC-S536	

FX-401 System Module and Annunciator Specifications

Table 22 FX-401 Modules and Annunciator Specifications

FX-401 System Modules and Annunciators		
RAM-3500-LCD	Remote annunciator	Standby 70mA / alarm 100mA
RAX-LCD-LITE	Remote annunciator	Standby 65mA / alarm 80mA
RTI-1	Remote trouble indicator	Normal standby 0mA / alarm 30mA maximum
PR-300	Polarity reversal and city tie module	
	City Tie	Power limited / 24VDC unfiltered / 270mA max / 13.7 and 14.4 Ω
	Polarity reversal	Power limited / 24VDC open / 12VDC at 3.5mA / 8mA max (shorted)
	Polarity reversal supv. terminal	24VDC (normal) / -24VDC (supervisory) / 0V (trouble)
	Polarity reversal alarm terminal	24VDC (normal) / -24VDC (alarm) / 0V (trouble)
	Current consumption	Standby 50mA / alarm 300mA (city tie in use) / alarm 70mA (city tie not in use)

Appendix E: Battery Calculations

IMPORTANT NOTICE

The main AC branch circuit connection for fire alarm control unit must provide a dedicated continuous power without provision of any disconnect devices. Use #12 AWG wire with 600-volt insulation and proper over-current circuit protection that complies with the local codes. For specifications see Appendix D.

Power Requirements (All currents are in amperes)

Model Number	Description	Qty		Standby	Total Standby	Alarm	Total Alarm
FX-401	FX-401 FACP with dialer		X	0.390	=	0.630	=
ALC-480	480 point dual loop adder		X	0.120	=	0.200	=
RAM-3500-LCD	Remote annunciator with 4-line LCD display		X	0.070	=	0.100	=
RAX-LCD-LITE	Remote annunciator with 4-line LCD display		X	0.065	=	0.080	=
PR-300	Polarity reversal and city tie module		X	0.050	=	0.300	=
SRM-312W and SRM-312R	Smart relay module		X	0.030	=	0.030 per relay LED	=
RAM-1032TZDS	32 point remote annunciator		X	0.050	=	0.300	=
RAX-1048TZDS	48 point adder annunciator display		X	0.022	=	1 zone active: 0.026 2 zone active: 0.030 3 zone active: 0.035 4 zone active: 0.039 48 zone active: 0.262	=
IPS-2424DS	Programmable input switches module with 24 switches		X	0.005	=	0.022	=
IPS-4848DS	Programmable input switches module with 48 switches		X	0.010	=	0.022	=
RTI-1	Remote trouble indicator, buzzer and LED		X	0.035	=	0.035	=
MIX-4040	Dual input module		X	0.0020	=	0.0033	=
MIX-4041	Mini dual input module		X	0.0020	=	0.0033	=
MIX-4042	Conventional zone module		X	0.0016	=	0.0030	=
MIX-4045	Dual relay module		X	0.0015	=	0.0031	=
MIX-4046	Supervised output module		X	0.0018	=	0.0025	=
MIX-4070	Short circuit isolator module		X	0.0006	=	0.0096	=
MIX-4010	Photoelectric smoke detector		X	0.000160	=	0.0032	=
MIX-4010-ISO	Photoelectric smoke detector with isolator		X	0.000160	=	0.0032	=
MIX-4020	Multi-sensor detector		X	0.000160	=	0.0032	=
MIX-4020-ISO	Multi-sensor detector with isolator		X	0.000160	=	0.0032	=
MIX-4030	Tri-mode heat detector		X	0.000160	=	0.0032	=
MIX-4030-ISO	Tri-Mode heat detector with isolator		X	0.000160	=	0.0032	=
MIX-4003-R	Relay base		X	0.00116	=	0.00118	=
MIX-4003-S	Sounder base		X	0.00156	=	0.00234	=
MIX-4040-M	Multi-input module		X	0.004	=	0.0083	=
MIX-4045-M	Multi-relay module		X	0.0019	=	0.0083	=

MIX-4070-M	Multi-isolator module		X	0.00056 per used section	=	0.0095 per activated section	=
MIX-4010-DUCT	Duct detector		X	0.000160	=	0.0032	=
INX-10A	Main chassis (10 amp)		X	0.035	=	0.0150	=
Device and remote LEDs (maximum 20 per loop)			X				=
Signal load (bells, horns, strobes, and etc.)			X				=
Auxiliary power supply (Aux 1, Aux 2, Unfiltered)					=		=
Total currents (add above currents)					STANDBY	(A)	(B)

Battery Capacity Requirement

Battery (Ah) = (Standby Current Total x Discharge Time) + (Alarm Current Total x Alarm Time)

([STANDBY (A) _____] X [(24 Hours) ____]) + ([ALARM (B) _____] X [Alarm in Hr.] _____) = (C) _____ Ah

Total alarm current must be **10** amperes or less. NAC Circuits must not exceed **6** amperes.

Battery Selection

Battery Size = Multiply (C) by 1.20 to derate battery.

See the following table for the recommended Mircom batteries for use with this panel

Table 23 Recommended Batteries

Battery Model	Battery Size
BAT-12V12A	12 Ah
BAT-12V18A	18 Ah
BAT-12V26A	26 Ah
BAT-12V42A	42Ah

BAT-12V12A (12 Ah) and BAT-12V18A (18 Ah) will fit into the FX-401 enclosure.

To house BAT-12V26A (26 Ah) and BAT-12V42A (42 Ah) batteries an external BC-160 battery cabinet is required.

Use of alternative batteries may result in failure of the panel to meet agency and regulatory requirements, and may result in shortened battery life. Batteries should be tested regularly, and replaced at least every three years. If the Battery Trouble indicator activates, obtain required service.

Warranty and Warning Information

WARNING!

Please read this document **CAREFULLY**, as it contains important warnings, life-safety, and practical information about all products manufactured by the Mircom Group of Companies, including Mircom and Secutron branded products, which shall include without limitation all fire alarm, nurse call, building automation and access control and card access products (hereinafter individually or collectively, as applicable, referred to as “**Mircom System**”).

NOTE TO ALL READERS:

1. **Nature of Warnings.** The within warnings are communicated to the reader out of an abundance of caution and create no legal obligation for Mircom Group of Companies, whatsoever. Without limiting the generality of the foregoing, this document shall NOT be construed as in any way altering the rights and obligations of the parties, governed by the legal documents that apply in any given circumstance.
2. **Application.** The warnings contained in this document apply to all Mircom System and shall be read in conjunction with:
 - a. the product manual for the specific Mircom System that applies in given circumstances;
 - b. legal documents that apply to the purchase and sale of a Mircom System, which may include the company’s standard terms and conditions and warranty statements;
 - c. other information about the Mircom System or the parties’ rights and obligations as may be application to a given circumstance.
3. **Security and Insurance.** Regardless of its capabilities, no Mircom System is a substitute for property or life insurance. Nor is the system a substitute for property owners, renters, or other occupants to act prudently to prevent or minimize the harmful effects of an emergency situation. Building automation systems produced by the Mircom Group of Companies are not to be used as a fire, alarm, or life-safety system.

NOTE TO INSTALLERS:

All Mircom Systems have been carefully designed to be as effective as possible. However, there are circumstances where they may not provide protection. Some reasons for system failure include the following. As the only individual in contact with system users, please bring each item in this warning to the attention of the users of this Mircom System. Failure to properly inform system end-users of the circumstances in which the system might fail may result in over-reliance upon the system. As a result, it is imperative that you properly inform each customer for whom you install the system of the possible forms of failure:

4. **Inadequate Installation.** All Mircom Systems must be installed in accordance with all the applicable codes and standards in order to provide adequate protection. National standards require an inspection and approval to be conducted by the local authority having jurisdiction following the initial installation of the system and following any changes to the system. Such inspections ensure installation has been carried out properly.
5. **Inadequate Testing.** Most issues and/or problems that would prevent a Mircom System alarm from operating as intended, can be identified through regular testing and maintenance. The complete system should be tested by the local authority having jurisdiction immediately after a fire, storm, earthquake, accident, or any kind of construction activity inside or outside

the premises. The testing should include all sensing devices, keypads, consoles, alarm indicating devices and any other operational devices that are part of the system.

NOTE TO USERS:

All Mircom Systems have been carefully designed to be as effective as possible. However, there are circumstances where they may not provide protection. Some reasons for system failure include the following. The end user can minimize the occurrence of any of the following by proper training, testing and maintenance of the Mircom Systems:

6. **Inadequate Testing and Maintenance.** It is imperative that the systems be periodically tested and subjected to preventative maintenance. Best practices, local codes, applicable laws and industry regulations, and any local authority having jurisdiction to do so, determine the frequency and type of testing that is required at a minimum. Mircom System may not function properly, and the occurrence of other system failures identified below may not be minimized, if the periodic testing and maintenance of Mircom Systems is not completed with diligence and as required.
7. **Improper Operation.** It is important that all system users be trained in the correct operation of the alarm system and that they know how to respond when the system indicates an alarm. A Mircom System may not function as intended during an emergency situation where the user is unable to operate a panic or emergency switch by reason of permanent or temporary physical disability, inability to reach the device in time, unfamiliarity with the correct operation, or related circumstances.
8. **Insufficient Time.** There may be circumstances when a Mircom System will operate as intended, yet the occupants will not be protected from the emergency due to their inability to respond to the warnings in a timely manner. If the system is monitored, the response may not occur in time enough to protect the occupants or their belongings.
9. **Carelessness or Safety Hazards.** Moreover, smoke detectors may not provide timely warning of fires caused by carelessness or safety hazards such as smoking in bed, violent explosions, escaping gas, improper storage of flammable materials, overloaded electrical circuits or children playing with matches or arson.
10. **Power Failure.** Some Mircom System components require adequate electrical power supply to operate. Examples include: smoke detectors, beacons, HVAC, and lighting controllers. If a device operates only by AC power, any interruption, however brief, will render that device inoperative while it does not have power. Power interruptions of any length are often accompanied by voltage fluctuations which may damage Mircom Systems or other electronic equipment. After a power interruption has occurred, immediately conduct a complete system test to ensure that the system operates as intended.
11. **Battery Failure.** If the Mircom System or any device connected to the system operates from batteries it is possible for the batteries to fail. Even if the batteries have not failed, they must be fully charged, in good condition, and installed correctly. Some Mircom Systems use replaceable batteries, which have a limited life-span. The expected battery life is variable and in part dependent on the device environment, usage and type. Ambient conditions such as high humidity, high or low temperatures, or large temperature fluctuations may reduce the expected battery life. Moreover, some Mircom Systems do not have a battery monitor that would alert the user in the event that the battery is nearing its end of life. Regular testing and replacements are vital for ensuring that the batteries function as expected, whether or not a device has a low-battery monitor.
12. **Physical Obstructions.** Motion sensors that are part of a Mircom System must be kept clear of any obstacles which impede the sensors' ability to detect movement. Signals being communicated by a Mircom System may not reach the receiver if an item (such as metal, water, or concrete) is placed on or near the radio path. Deliberate jamming or other inadvertent radio signal interference can also negatively affect system operation.

13. **Wireless Devices Placement Proximity.** Moreover all wireless devices must be a minimum and maximum distance away from large metal objects, such as refrigerators. As the end user, you are required to consult the specific Mircom System manual and application guide for any maximum distances required between devices and suggested placement of wireless devices for optimal functioning.
14. **Failure to Trigger Sensors.** Moreover, Mircom Systems may fail to operate as intended if, motion, heat, carbon monoxide (CO) and/or smoke sensors, are not triggered.
 - a. Sensors in a fire system may fail to be triggered when the fire is in a chimney, walls, roof, or on the other side of closed doors. Smoke and heat detectors may not detect smoke or heat from fires on another level of the residence or building. In this situation the control panel may not alert occupants of a fire.
 - b. Sensors in a nurse call system may fail to be triggered when movement is occurring outside of the motion sensors' range. For example, if movement is occurring on the other side of closed doors or on another level of the residence or building the motion detector may not be triggered. In this situation the central controller may not register an alarm signal.
15. **Interference with Audible Notification Appliances.** Audible notification appliances may be interfered with by other noise sources such as stereos, radios, televisions, air conditioners, appliances, or passing traffic. Audible notification appliances, however loud, may not be heard by a hearing-impaired person.
16. **Other Impairments.** Alarm notification appliances such as sirens, bells, horns, or strobes may not warn or waken a sleeping occupant if there is an intervening wall or door. It is less likely that the occupants will be alerted or awakened when notification appliances are located on a different level of the residence or premise.
17. **Software Malfunction.** Most Mircom Systems contain software. No warranties are provided as to the software components of any products or stand-alone software products within a Mircom System. For a full statement of the warranties and exclusions and limitations of liability please refer to the company's standard Terms and Conditions and Warranties.
18. **Telephone Line/Network Malfunction.** Telephone service can cause system failure where telephone lines/networks are relied upon by a Mircom System. Alarms and information coming from a Mircom System may not be transmitted if a phone line/network is out of service or busy for a certain period of time. Alarms and information may not be transmitted where telephone lines/networks have been compromised by criminal tampering, local construction, storms or earthquakes.
19. **Component Failure.** Although every effort has been made to make this Mircom System as reliable as possible, the system may fail to function as intended due to the failure of a component.
20. **Integrated Products.** Mircom System might not function as intended if it is connected to a non-Mircom product or to a Mircom product that is deemed non-compatible with a particular Mircom System. A list of compatible products can be requested and obtained.
21. A Mircom System's Auto Configuration feature is intended to assign the Alarm process type to all inputs and to provide an initial set up by detecting connected devices and generates a basic job configuration upon the initial installation of the Mircom System. Mircom makes no representations, warranties or guarantees regarding the accuracy or suitability of the basic job configuration generated upon installation, for any specific site requirements. The end user shall be solely and exclusively responsible to thoroughly review the basic job generated by the auto configuration feature upon initial installation and to implement necessary adjustments and modifications to customize the job configuration in accordance with the functional and/or technical requirements of the site. Mircom expressly disclaims any responsibility or liability for any failure, malfunction or defective operation of a Mircom System and any associated components, resulting from the end user's failure to customize or adjust the job configuration accordingly.

By installing and utilizing the Mircom System, the user acknowledges and agrees that Mircom shall not be liable for any claims, losses, damages, or defects arising from the failure of the user or installer and those for whom it is responsible at law, to customize the basic job configuration generated on the initial set-up in accordance with the requirements of the site.

Warranty

Purchase of all Mircom products is governed by:

<https://www.mircom.com/product-warranty>

<https://www.mircom.com/purchase-terms-and-conditions>

<https://www.mircom.com/software-license-terms-and-conditions>



CANADA - Main Office
25 Interchange Way
Vaughan, ON L4K 5W3
Tel: (905) 660-4655
(888) 660-4655
Fax: (905) 660-4113

U.S.A
4575 Witmer Industrial Estates
Niagara Falls, NY 14305
Tel: (905) 660-4655
(888) 660-4655
Fax: (905) 660-4113

© Mircom 2025
Printed in Canada
Subject to change without prior notice

www.mircom.com