



FX-MNS-6000

Network Fire Alarm and Emergency Communication System

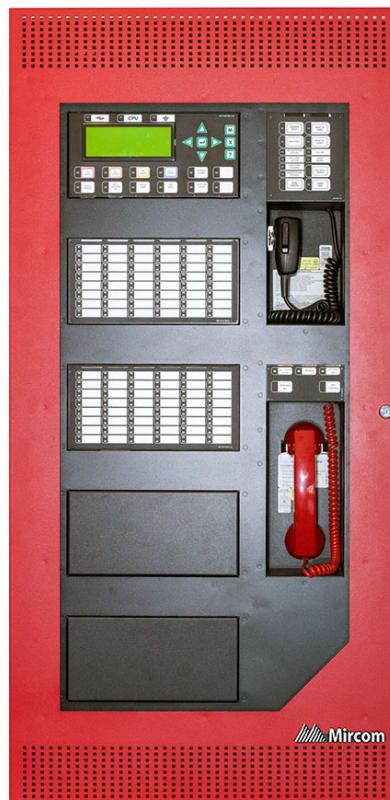

Table of Contents

1.0	Introduction	11
1.1	The FX-MNS-6000 Network Fire and Emergency Communication System	11
1.2	Document Conventions	14
1.3	FX-MNS-6000 Fire and Audio Expansion System Layout	14
1.4	FX-MNS-6000 Fire with Audio Expansion System Layout	16
2.0	System Components	17
3.0	Installation	25
3.1	BBX-FXMNS-6000 Enclosure Installation	25
3.2	QBB-6001 Expansion Audio Cabinet Installation	29
3.3	QBB-6001 Enclosure	30
3.4	Display Modules	31
4.0	Module Settings	32
4.1	Main Fire Alarm Module (MD-871A “N” Version Main Chassis)	32
4.2	DSPL-420DS Main Display Module	33
4.3	DSPL-2440DS Graphical Main Display Module	34
4.4	FNC-2000 Fire Network Controller Module	35
4.5	FOM-2000-UM Fiber Optic Network Module	36
4.6	RAX-1048TZDS Zone Display Module	37
4.7	IPS-4848DS Programmable Input Switches Module	38
4.8	IPS-2424DS Programmable Input Switches Module	39
4.9	FDX-008W(KI) Fan Damper Control Display Module	40
4.10	DM-1008A Hardwire Detection Adder Module	43
4.11	SGM-1004A Hardwire Signal Adder Module	44
4.12	SGM-1004S 4 NAC Output Module with Built-in Sync	46
4.13	RM-1008A Hardwire Relay Adder Module	50
4.14	Polarity Reversal and City Tie Module PR-300	51
4.15	UDACT-300A Main Board	52
4.16	ALCN-960MISO Isolated Quad Loop Adder Module with ALCN-960D Daughter Board	54
4.17	ALCN-4792MISO Isolated Quad Loop Adder Module with ALCN-792D Daughter Board	57
5.0	Field Wiring for Fire Alarm	60
5.1	Main Fire Alarm Board Wiring	60
5.2	Addressable Loop Wiring	62
5.3	Network Wiring	65
5.4	Analog Initiating Wiring	67

5.5	Analog NAC Wiring	68
5.6	Analog Relay Wiring	70
5.7	Polarity Reversal and City Tie Module PR-300 Wiring	71
5.8	UDACT-300A Main Board Terminal Connections	72
5.9	Power Supply Wiring	73
5.10	Wiring Tables and Information	75
6.0	Field Wiring for Audio	77
6.1	QBB-6001 Enclosure (Expansion Cabinet) Assembly	77
6.2	Installing and Removing Amplifiers	78
6.3	QCC-6000 Communication Card	79
6.4	ANC-6000 Audio Network Controller Board and TNC-5000 Telephone Network Card .	83
6.5	ANC-6000 Audio Network Controller Board	84
6.6	ANC-6000 Wiring	85
7.0	QMP-6101N(V) Paging Control Modules	86
7.1	QMP-6101NV Vertical Paging Control Module	86
7.2	QMP-6101N Horizontal Paging Control Module	87
7.3	Wiring	89
8.0	QAZT-5302DS and QAZT-5348DS Zoned Paging Selector Panels	90
9.0	Paging Operation	91
9.1	QMP-6101N(V) LEDs	91
9.2	QMP-6101N(V) Pushbutton Controls	92
9.3	QAZT-5302DS and QAZT-5348DS Paging Selector Panel LEDs	92
9.4	QAZT-5302DS and QAZT-5348DS Pushbutton Controls	92
10.0	TNC-5000 Telephone Network Controller Module	93
10.1	Module Mounting Locations	93
10.2	Typical Addressable Telephone Set-up	93
10.3	Connectors and Terminal Locations	94
10.4	TNC-5000 Telephone Wiring	95
10.5	QMT-5302NV Vertical Master Telephone	97
10.6	QMT-5302NV Connections	98
10.7	QAZT-5348DS Network Firefighters' Telephone Selector Panel	98
10.8	Telephone Operation	99
10.9	QMT-5302NV Master Telephone LEDs	100
10.10	QMT-5302NV Master Telephone Pushbutton Controls	100

10.11	QAZT-5348DS Network Telephone Selector Panel LEDs	100
10.12	QAZT-5348DS Network Telephone Selector Panel Pushbuttons	100
11.0	Audio Amplifier Wiring	101
11.1	Amplifier Mounting Installation	101
11.2	Amplifier Wiring	104
12.0	Indication	111
12.1	Amplifier Displays	111
13.0	Audio Configuration	112
14.0	System Checkout	113
14.1	Before Turning the Power On	113
14.2	Power-Up Procedure	113
14.3	Troubleshooting	113
15.0	Indicators, Controls, and Operation	114
15.1	Common Indicators	115
15.2	Common Controls	116
15.3	Single Stage Operation	119
15.4	Two Stage Operation	119
15.5	Pre-Signal Operation	121
15.6	Circuit Types	121
16.0	Configuration	124
16.1	Configuration Backup, Query and Fast-Forward	124
16.2	Open Graphic Navigator Software Package	124
16.3	Ethernet Port	124
16.4	Boolean Logic Engine	124
16.5	Multiple Configuration file support	124
Appendix A:	Specifications	125
Appendix B:	Power Supply and Battery Calculations	128
Appendix C:	DIP Switch Settings	131
Appendix D:	Alarm Verification Timing	133

Appendix E:	Wiring For Addressable Supervised Output Module	134
Appendix F:	Power Supply and Batteries for Audio Expansion Cabinet QBB-6001	135
Appendix G:	APB-200/COA Sounder Bases	136
Appendix H:	ULC Compatible Speakers with Temporal 520Hz Square Wave Low Frequency Signal	137
Appendix I:	UL Compatible Speakers with Temporal 520Hz Square Wave Low Frequency Signal	140
Appendix J:	Example Configuration Setup	142
	Warranty and Warning Information	158

List of Figures

Figure 1	Typical FX-MNS-6000 Layout	15
Figure 2	Typical FX-MNS-6000 Layout with Audio Expansion	16
Figure 3	BBX-FXMNS-6000 Enclosure	25
Figure 4	BBX-FXMNS-6000 Enclosure Complete View	26
Figure 5	BBX-FXMNS-6000 Backbox Dimensions and Contents	27
Figure 6	BBX-FXMNS-6000 Inner Door	28
Figure 7	QBB-6001 Dimensions, Mounting Holes and Knockouts for Installation	29
Figure 8	QBB-6001 Expansion Audio Cabinet Module Placement	30
Figure 9	Main Fire Alarm Module (MD-871A"N" Version Main Board.	33
Figure 10	DSPL-420DS Main Display Module (Part of Main Chassis c/w Main Fire Alarm Module)	33
Figure 11	DSPL-2440DS Graphical Main Display Module	34
Figure 12	FNC-2000 Fire Network Controller Module	35
Figure 13	FOM-2000-UM Fiber Optic Network Module	36
Figure 14	Zone Display Module RAX-1048TZDS	37
Figure 15	IPS-4848DS Programmable Input Switches Module	38
Figure 16	IPS-4848DS Wiring	38
Figure 17	IPS-2424DS Programmable Input Switches Module	39
Figure 18	Fan Damper Control Display Module FDX-008W(KI)	40
Figure 19	FDX-008W Block Diagram of Fan and Monitor Set-up	41
Figure 20	FDX-008WKI Fan Damper Control Display Module	42
Figure 21	Hardwire Detection Adder Module DM-1008A	43
Figure 22	Hardwire Signal Adder Module SGM-1004A	44
Figure 23	Signal Adder Module SGM-1004S	46
Figure 24	Suite Isolator Mode Wiring	49
Figure 25	Signal Silence Mode Wiring	50
Figure 26	Hardwire Relay Adder Module RM-1008A	50
Figure 27	Polarity Reversal and City Tie Module	51
Figure 28	UDACT-300A Board Layout	52
Figure 29	ALCN-960MISO Isolated Quad Loop Adder Module	55
Figure 30	ALCN-960D Daughter Board	56
Figure 31	ALCN-4792MISO Quad Loop Adder Module	58
Figure 32	ALCN-792D Daughter Board	59
Figure 33	Main Fire Alarm Controller Board Field Terminal Connections	60
Figure 34	Main Fire Alarm Control board Field Terminal Connections (continued)	61
Figure 35	Quad Loop Terminal Connections - Class B	62
Figure 36	Quad Loop Adder Module Terminal Connections - Class X (Formerly Style 7)	63
Figure 37	Quad Loop Adder Module Terminal Connections - Class A	64
Figure 38	Class X Wiring for the FNC-2000 Module	65
Figure 39	FOM-2000-UM Fiber Optic Network Adder Module Wiring	66
Figure 40	Hardwire Detection Module DM-1008A Terminal Connections	67
Figure 41	Hardwire Signal Module SGM-1004A Terminal Connections	68
Figure 42	Hardwire Signal Module SGM-1004S Terminal Connections	69
Figure 43	Hardwire Relay Module RM-1008A Terminal Connections	70

Figure 44	Polarity Reversal and City Tie Module PR-300 Terminal Connection	71
Figure 45	Telephone Line Wiring Diagram	72
Figure 46	Power Supply Connections	73
Figure 47	Power Supply Connections within BBX-FXMNS-6000 Enclosure.	74
Figure 48	QBB-6001 Expansion Audio Cabinet Module Placement	77
Figure 49	Installing an Amplifier	78
Figure 50	QCC-6000 Communications Card	80
Figure 51	QCC-6000 Rotary Switch	80
Figure 52	Field Wiring between QCC-6000s Class B	81
Figure 53	Installing the QCC-6000 Communications Card.	81
Figure 54	QCC-6000 Communications Class B Wiring	82
Figure 55	QCC-6000 Communications Class A Wiring	82
Figure 56	Mounting the Audio and Telephone Card over the Main Fire Alarm Board in FX-6000MNS-CH	83
Figure 57	ANC-6000 Audio Network Controller board	84
Figure 58	ANC-6000 Wiring Diagram	85
Figure 59	QMP-6101NV Vertical Paging Control Module	86
Figure 60	QMP-6101N Horizontal Paging Control Module	87
Figure 61	QMP-6101N Horizontal Paging Control Module Mounting	88
Figure 62	QMP-6101N and QMP-6101NV Paging Control Module Connections and Terminal Blocks	89
Figure 63	QAZT-5302DS (top) and QAZT-5348DS (bottom)	90
Figure 64	Typical Addressable Telephone Set-up	93
Figure 65	TNC-5000 Telephone Network Controller Board Layout	94
Figure 66	Telephone Bus Wiring Diagram	95
Figure 67	TNC-5000 Telephone Zone Wiring	96
Figure 68	QMT-5302NV Master Firefighters' Telephone	97
Figure 69	QMT-5302NV Cable Connection and Terminal Wiring	98
Figure 70	QAZT-5348DS Network Firefighters' Telephone Selector Panel	98
Figure 71	QAZT-5348DS Telephone Selector Panel Cable Connections	99
Figure 72	Installing the Amplifiers into the QMB-6000 Card Cage	102
Figure 73	QMB-6000 Terminals for Amplifier Wiring	103
Figure 74	Wiring for 100 Watt Amplifier Circuit	104
Figure 75	Wiring for 75W and 25W Amplifier Circuits	105
Figure 76	Wiring for 50W Amplifier Circuits	106
Figure 77	Wiring for 25W Amplifier Circuits	108
Figure 78	Backup Amplifier Class A Wiring	109
Figure 79	Backup Amplifier Class B Wiring	109
Figure 80	Audio Cabinet Displays and Controls	111
Figure 81	Indicators and Control Location	114
Figure 82	Evacuation Codes	123
Figure 83	Address Dials	132
Figure 84	Sounder Base Wiring to Auxiliary Power Supply with Supervision (Class B only)	136
Figure 85	Example Setup	142
Figure 86	New Job	144
Figure 87	New Job Description	144

Figure 88	Job Details	145
Figure 89	Audio Setup	145
Figure 90	Add Audio Controller	146
Figure 91	Add ANC-6000	146
Figure 92	Add Loop Controllers	146
Figure 93	Add Loop Controller	147
Figure 94	Add UDACT	147
Figure 95	Add UDACT	147
Figure 96	Add Network Nodes	147
Figure 97	Add Network Nodes	148
Figure 98	Add Display Adder	148
Figure 99	Add Display Adder	148
Figure 100	Add Master Paging	148
Figure 101	Add Amplifier	149
Figure 102	Add Amplifiers	149
Figure 103	Amplifiers	149
Figure 104	Add Device	150
Figure 105	Devices	150
Figure 106	Page Selector Switches	150
Figure 107	LED Assignment	150
Figure 108	Add Zones	151
Figure 109	Input Zones	151
Figure 110	Add correlations to input zones	151
Figure 111	Add Correlations	152
Figure 112	48 LED Adder input zones	152
Figure 113	Telephone/Page Selector amplifier correlations	152
Figure 114	Telephone/Page Selector digital message correlations	153
Figure 115	Dialer settings	153
Figure 116	2 x 24 SW Adder	154
Figure 117	Configure Job for Two Stage	154
Figure 118	Correlate Node Alarm to Amplifiers	155
Figure 119	Add Input Zones	155
Figure 120	Enable GA Flag	156
Figure 121	Add Manual Stations	156
Figure 122	Correlate Manual Stations to Input Zones	156
Figure 123	Correlate Input Zones to Signals	156
Figure 124	Assign LEDs	157
Figure 125	Correlate LEDs to Input Zones	157

List of Tables

Table 1:	FX-MNS-6000 System Components	17
Table 2:	FNC-2000 Module List of Connectors and Jumpers and Functions	35
Table 3:	FOM-2000-UM Fiber Optic Network Module Cable Connection	36
Table 4:	RAX-1048TZDS Zone Display Module Cable Function	37
Table 5:	IPS-4848DS Programmable Input Switches Module Cable Function	38
Table 6:	IPS-2424DS Programmable Input Switches Module Cable Function	39
Table 7:	SGM-1004S Terminal and Jumper Descriptions	46
Table 8:	SGM-1004S DIP Switch 1	47
Table 9:	SGM-1004S Bell Cut Select	47
Table 10:	Jumpers for Suite Isolator Mode	48
Table 11:	PR-300 jumper settings	51
Table 12:	UDACT-300A Connectors	52
Table 13:	UDACT-300A LEDs	53
Table 14:	UDACT-300A Jumpers	53
Table 15:	QPS-6650 Ratings	73
Table 16:	Wiring for Initiating Circuits	75
Table 17:	Wiring for NACs	75
Table 18:	Analog Loop Wiring	76
Table 19:	ANC-6000 and QMP-6101N(V) Wiring	89
Table 20:	Connectors on TNC-5000	94
Table 21:	Audio Amplifier Wiring	101
Table 22:	Wiring of 75W and 25W Speakers	105
Table 23:	Wiring of 50W and 25W Speakers	107
Table 24:	Wiring Chart for 70V Speakers	110
Table 25:	Wiring Chart for 25V Speakers	110
Table 26:	End of Line Resistor Value for Amplifier Circuits	110
Table 27:	Troubleshooting	113
Table 28:	Common Indicators	115
Table 29:	Initiating (Detection) Circuit Types	121
Table 30:	Initiating (Signal) Circuit Types	122
Table 31:	Settings Permitted in CAN/ULC-S527and CAN/ULC-S559	124
Table 32:	Specifications	125
Table 33:	FX-MNS-6000 Audio Specifications	127
Table 34:	Node Builds	142

1.0 Introduction

1.1 The FX-MNS-6000 Network Fire and Emergency Communication System

Mircom's FX-MNS-6000 Network Fire Alarm and Emergency Communication system offers modular components for network systems providing a wide variety of applications. Designed for peer to peer network communications, using industrial standard ARCnet protocol. The FX-MNS-6000 allows for a maximum of 63 nodes (where a node can be a control center or a floor panel) while providing reliability and flexibility. This fire alarm and audio system provides zoned emergency multi-channel audio with emergency paging and fire evacuation, and an optional firefighters' telephone communication to and from the CACF (Central Alarm and Control Facilities) location to all remote telephone handsets.

Each integrated fire and audio network panel or BBX-FXMNS-6000 node consists of an enclosure which contains both an audio portion and a fire alarm portion. The fire alarm portion consists of an FX-6000MNS-CH Main Chassis, which accommodates the main fire alarm control board, an ANC-6000 Audio Network Card, and a TNC-5000 Telephone Network Card. The audio portion consists of a QMB-6000 card cage that holds up to 4 amplifier modules and 1 QCC-6000 Communication Card (1 per enclosure). Also, within this BBX-FXMNS-6000 enclosure is a QPS-6650 power supply and batteries.

MGC Protocol Quad Loop Adder module ALCN-960MISO provides 2 SLC loops for MGC MIX-4000 Series addressable devices; with daughter board ALCN-960D expanding addressable loops to 4. Also available is the Quad Loop Adder module ALCN-4792MISO for 2 addressable SLC loops for CLIP and AP devices; with daughter board ALCN-792D expanding addressable loops to 4.

There are also 4 Class A/B Indicating Circuits (NACs) rated at 1.7 amperes each and connection for any of our display modules DSPL-420DS, DSPL-2440DS and DSPL-420-16TZDS.

The paging microphone and firefighters' telephone may be used together or independently, connected to a Central Alarm and Control Facility (CACF).

For communication and annunciation there is a microphone for paging, a paging selector panel, firefighters' telephone and associated selector panels all housed in a central enclosure (CACF). The master paging and telephone modules are intended for installation in a CACF.

The QBB-6001 is an expansion audio only cabinet (connected to an BBX-FXMNS-6000 node). It has capacity for 2 QMB-6000 card cages which hold up to 4 QAD-6425-25/QAD-6425-70 amplifier modules each for a total of 8 amplifiers and a QCC-6000 Communication Card (1 per enclosure). Also contained in this cabinet is a QPS-6650 power supply and batteries.

1.1.1 Overall Fire Alarm Features

- Large System Capacity and Modular Design.
- Provides peer-to-peer network communications.
- Supports up to 63 nodes (including lobby panel).
- Supports copper and/or fiber optic network cable.
- Supports a request, grant, or deny system with all controls disabled on node annunciators as per ULC 527.

- Supports a degraded mode of operation (more than one operating node) and a standalone mode of operation (only one operating node) as per ULC 527.
- MGC Protocol Quad Loop Adder module ALCN-960MISO for expanding addressable loops (SLC) by 2; with daughter board ALCN-960D expanding addressable loops by a total of 4. Each SLC Loop is set to function with MGC MIX-4000 Series addressable modules (240 sensors and modules) and can be wired as Class A (Class X) or Class B.
- AP Protocol Quad Loop Adder module ALCN-4792MISO for expanding addressable loops (SLC) by 2; with daughter board ALCN-792D expanding addressable loops by a total of 4.
- QPS-6650 27 A @ 24V DC Power Supply.
- Four Class A/B NACs rated at 1.7 amperes each, which can be configured as Audible or Visual (silenceable or non-silenceable circuits). Audibles may be steady, Temporal Code, California Code, or March Time.
- Indicating circuits (NACs) may be configured to provide additional auxiliary power or resettable auxiliary power. NAC expansion using the INX-10A and INX-10ADS.
- Fault isolators are present on all in-panel addressable loops.
- Configurable Signal Silence Inhibit, Auto Signal Silence, Two-Stage Operation, Assisted Walk Test.
- Outputs for 4 Wire resettable Smoke Power Supply, Auxiliary Power Supply, and an interface to the Mircom RTI-1 Remote Trouble Indicator.
- RS-485 Interface for Remote Annunciators. Remote Annunciators do not occupy a node on the network. Up to seven annunciators can be connected per node.
- Three Level Password Protection with field settable definition which enables the installer to determine what functions are accessible for each level of password
- Four queues for acknowledge with Alarm ACK, Supervisory ACK, Trouble ACK, and BLDG (Monitor) ACK LED indicators and pushbuttons.
- Auxiliary Form-C Relay Contacts for Common Alarm, Common Supervisory, and Common Trouble.
- RS-232 Port for remote system printer or laptop.
- Two Event History Logs; one for Alarm related events and one for all events.
- Large 4 line by 20 character alphanumeric, back-lit LCD Display with user-friendly menu system.
- Common Controls and Indicators for System Reset, Lamp Test, Fire Drill, Signal Silence, General Alarm, General Alarm Acknowledge, AC On, CPU Fault, and Ground Fault.
- Two Spare configurable switches and LED Indicators.
- DSPL-420-16TZDS 16 zone configurable LED (bi-coloured) annunciator with slide-in labels for zone description.
- Provides drift compensation for ionization and photoelectric smoke detectors
- Provides Signal Coding of signal circuits for easy alarm identification (code consists of 1 to 4 digits, each digit consisting of 1-15 pulses on the signal)
- Selection for Canadian (ULC) or USA (UL) requirements for Smoke Sensor sensitivity.
- Extensive transient protection.
- Surface Mountable Enclosures with removable doors for easy installation and service.
- Removable Terminal Blocks for easy wiring and service.
- Amplifier modules are removable without touching field wiring.

- The BBX-FXMNS-6000 enclosure is for the Integrated Fire and Audio consisting of a backbox, door and middle chassis. Part of this enclosure is the vertical mount telephone QMT-5302NV and the vertical mount paging microphone QMP-6101NV.
- The RAXN-4000LCDG and RAXN-4000LCDGC are graphical display remote annunciators.
- The FleX-Net™ FX-4000 is compatible with COPTIR, Pinnacle, Acclimate and 4-20mA devices.
- Configuration options are provided for grouping inputs.
- Panel supports previous, current and next configuration. Configuration automatically reverts back to previous or moves to future configuration through front-panel menu.
- Open Graphic Navigator Software Package (OpenGN) allows 3D graphic display of premises and devices. Use the Ethernet port on the main board to connect to OpenGN graphics software.
- Boolean logic functions are now available within the configuration software.
- Allows a choice of multiple configuration files to support site-specific requirements.
- The FleXBoot™ shell offers UNIX style commands for directory listing, log download, diagnostic probing and system tuning and optimization.

1.1.2 Overall Audio Features:

- Supervises signal circuits while in use.
- Control of fire management operations (e.g. all-call paging and total evacuation signalling).
- Indication of all required fault conditions.
- Microprocessor-based operations with hardware and software watchdog timer to ensure reliable system operation.
- Supervised tone generators.
- Up to 100 audio zones per node, 4788 audio amplifiers per Network system:
((4 + 9*8 (2 full expansion bins)) * 63 nodes
- Up to 5 (analog) firefighters' telephone zones per node and 315 (analog) telephone zones per Network system. 99 addressable telephone zones per loop on ALCN-4792MISO, 240 addressable telephone zones per loop on ALCN-960MISO, maximum of 29 addressable telephone loops per node, maximum of 144 addressable telephone zones per system.
- Operates from 24 VDC backup batteries in the event of a power failure.
- Removable terminal blocks for ease of installation and maintenance.
- Maximum of 100 watts per amplifier module.
- Maximum of 575 watts per expansion cabinet.
- Supports up to 10 audio cabinets (1 main plus 9 expansion audio cabinets).
- Each expansion audio cabinet up to 2000 feet.
- Optional redundant backup amplifier per node.
- Multi-channel playback.
- Auxiliary Audio Input with amplifier supervision during non-fire use.
- Each amplifier can play an independent message.
- Each amplifier can be Class A and Class B field wired.

1.2 Document Conventions

1.2.1 Circuits and Zones

The term **circuits** refers to an actual electrical interface, initiating (detection), indicating (signal), or relay.

The term **zone** is a logical concept for a fire alarm protected area, and will consist of at least one circuit.

Often the terms **zone** and **circuit** are used interchangeably, but in this manual the term circuit is used.

On the FleX-Net™ FX-4000, circuits can be hardwired inputs and outputs or addressable inputs and outputs. Both hardwired inputs and outputs, and addressable inputs and outputs may be grouped together to form logical zones.

1.2.2 Wiring Styles

Initiating circuits are configured by default as Class B. They may be configured as Class A as described in System Configuration. This operation uses odd and even pairs of two-wire Class B circuits to make one four-wire Class A circuit, thus cutting in half the number of available initiating circuits.

Indicating circuits (NACs) may be individually wired as Class A or Class B without affecting the number of circuits available.

Addressable Loops may be configured system wide as Class B or Class A. With the addition of isolators, a Class A will become a Class X.

1.3 FX-MNS-6000 Fire and Audio Expansion System Layout

Figure 1 shows a typical FX-MNS-6000 system layout with the main lobby control panel as Node 1 and the combination of fire and audio systems as Node 2 and 3. The diagram also shows addressable fire alarm loops, paging and telephone connections and QBB-6001 extension audio cabinets.

FX-MNS-6000 Fire Alarm and Audio Layout

Figure 1 Typical FX-MNS-6000 Layout

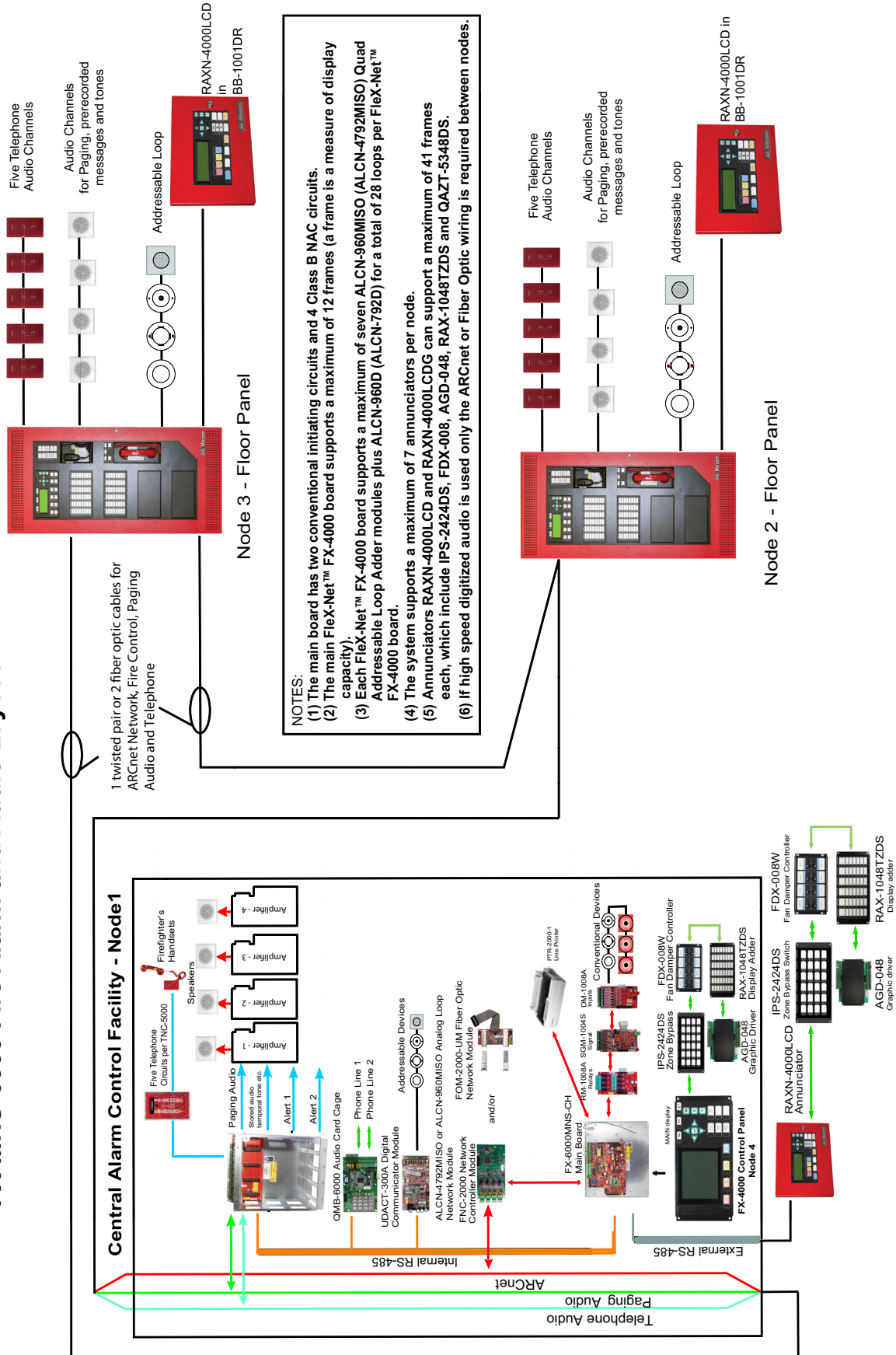

1.4 FX-MNS-6000 Fire with Audio Expansion System Layout

The figure below shows a typical FX-MNS-6000 system layout with the main lobby control panel as Node 1 and the combination of fire and audio systems as Node 2 and 3. The diagram also shows addressable fire alarm loops, paging and telephone connections and QBB-6001 extension audio cabinets.

Figure 2 Typical FX-MNS-6000 Layout with Audio Expansion

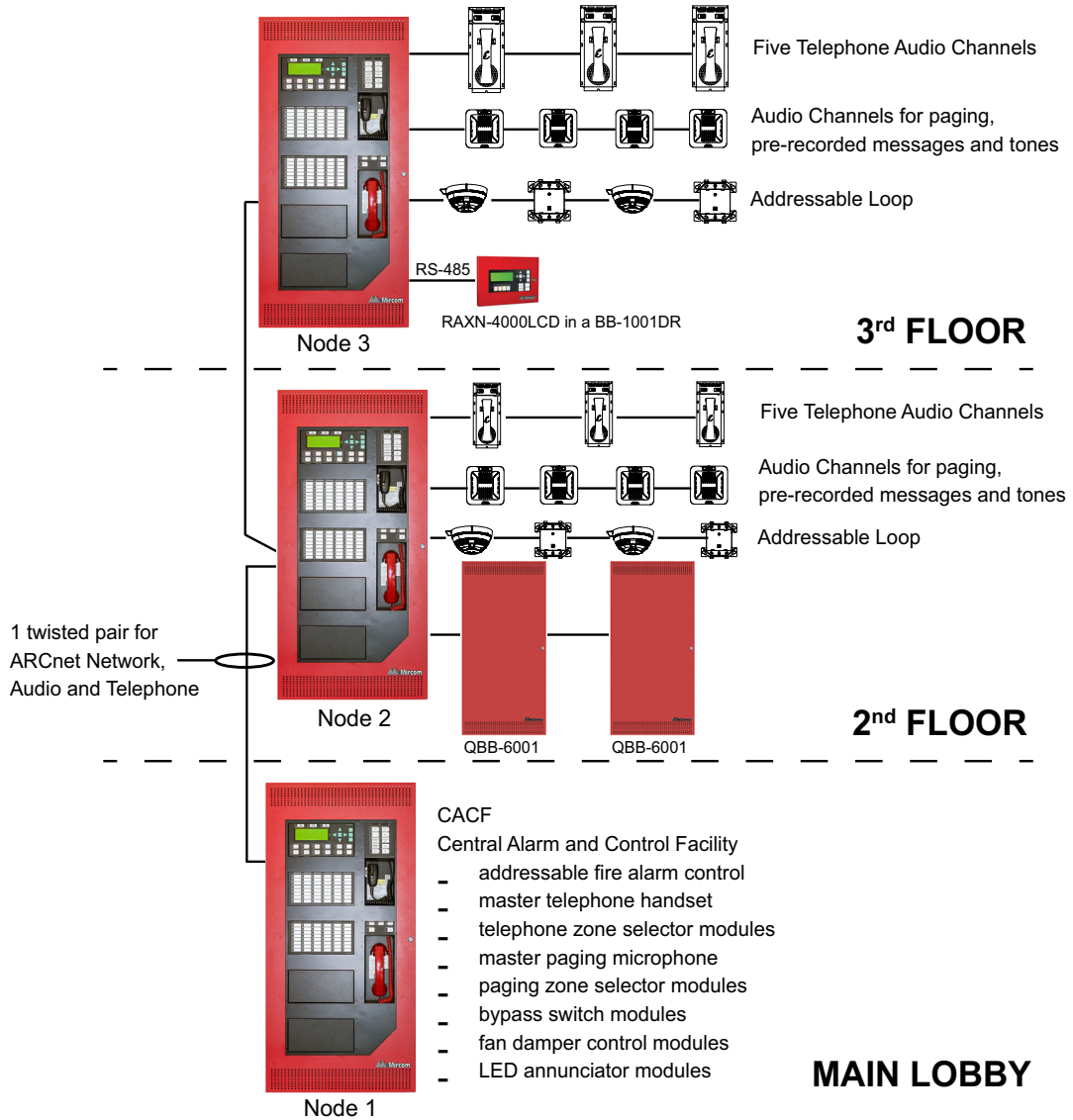

2.0 System Components

Table 1: FX-MNS-6000 System Components



	Model	Description
	BBX-FXMNS-6000 Enclosure	Each FX-MNS-6000 integrated fire and audio network panel consists of a BBX-FXMNS-6000 enclosure which contains an audio portion QMB-6000 card cage that holds up to 4 amplifiers and a QCC-6000 Communication Card, a fire alarm portion FX-6000MNS-CH Main Chassis, which holds the main fire alarm control board, an ANC-6000 Audio Network Card, a TNC-5000 Telephone Network Card and a QPS-6650 power supply, and batteries. The QBB-6001 expansion audio cabinet (connected to an FX-MNS-6000 node) contains up to a maximum of two QMB-6000 card cages which holds up to 4 amplifiers each for a total of 8 amplifiers, one QCC-6000 Communication Card, a QPS-6650 power supply and batteries.
	QBB-6001 Audio Expansion Enclosure	Consists of a backplate which is mounted into the BBX-FXMNS-6000 backbox and a main Fire Alarm Control board. This backplate can accommodate up to 10 adder modules (including 3 controller modules). The Fire Alarm Control board includes four Class A/B NACs.
	FX-6000MNS-CH	Provides network capability for the main Fire Alarm Control board. One module is required per one network node panel. The FNC-2000 Fire Network Controller module is mounted in position 2 over the main fire alarm control board.
	FNC-2000	Provides network capability for the main Fire Alarm Control board. One module is required per one network node panel. The FNC-2000 Fire Network Controller module is mounted in position 2 over the main fire alarm control board.

Table 1: FX-MNS-6000 System Components (Continued)

	Model	Description
	ANC-6000	Audio Network Controller module. The ANC-6000 Audio Network Controller module is mounted in a BBX-FXMNS-6000 or QBB-6001 backbox over the main fire alarm board.
	TNC-5000	Telephone Network Controller module. This module is mounted over the ANC-6000 module. The recommended mounting of the TNC-5000 is sideways with LEDs across the top.
	QCC-6000	1 Communication Card is required in every enclosure. It mounts on the right side of the QMB-6000 backplane.
	QPS-6650	27 A @ 24V DC power supply
	FOM-2000-UM	Single Mode or Multi-Mode Fiber Optics Module (Optional) Connects to the FNC-2000 Fire Alarm Network Controller Module and allows fiber optics cabling.
	ALCN-960MISO	MGC Protocol Quad Loop Adder module provides two SLC loops.

Table 1: FX-MNS-6000 System Components (Continued)

Model	Description
	<p>ALCN-960D</p> <p>MGC Protocol Quad Loop Daughter Adder board provides an additional two SLC loops to the two provided with the ALCN-960MISO.</p>
	<p>ALCN-4792MISO</p> <p>AP Protocol Quad Loop Adder module provides two SLC loops.</p>
	<p>ALCN-792D</p> <p>AP Protocol Quad Loop Daughter Adder board provides an additional two SLC loops to the two provided with the ALCN-4792MISO.</p>
	<p>DM-1008A</p> <p>Eight Initiating Circuit Module</p>
	<p>SGM-1004A</p> <p>Four NAC Circuit Module</p>
	<p>SGM-1004S</p> <p>Four NAC Circuit Module with built-in Synchronization</p>

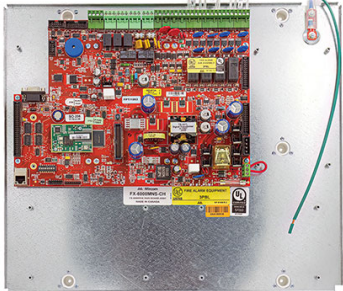
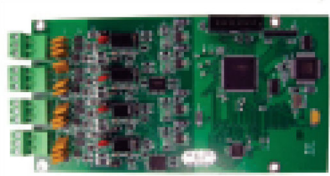
Table 1: FX-MNS-6000 System Components (Continued)



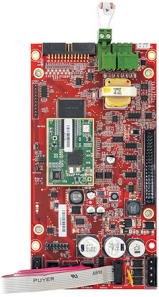
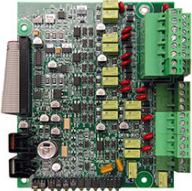
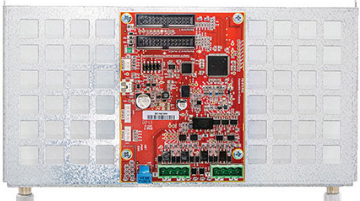
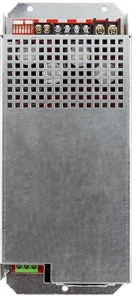
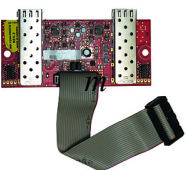
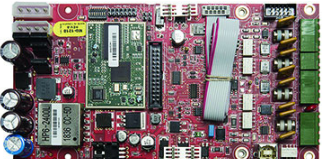

	Model	Description
	RM-1008A	Eight Relay Circuit Module
	PR-300	Polarity Reversal and City Tie Module
	UDACT-300A	Digital Communicator/Dialer Module
	FDX-008W(KI)	Fan Damper Module with white LEDs for AUTO switch position indication. FDX-008W provides switch operation of 8 fan damper zones and the FDX-008WKI provides switch operation of 7 fan damper zones and one keyswitch operation of the 8th fan damper zone
	DSPL-420DS	4 line by 20 character display which can be mounted into backbox BBX-FXMNS-6000 backbox
	DSPL-2440DS	Graphic display which can be mounted in the BBX-FXMNS-6000 backbox
	DSPL-420-16TZDS	4 line by 20 character display which provides 16 zone alarm and trouble indicators. can be mounted in the BBX-FXMNS-6000 backbox

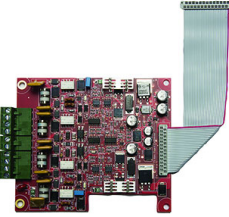
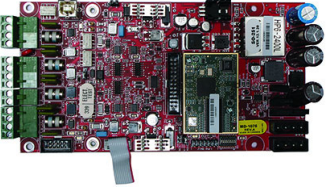
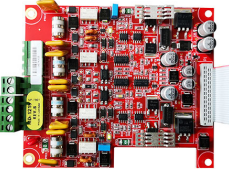
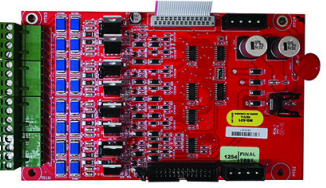
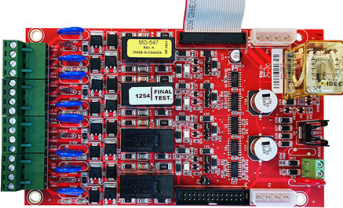
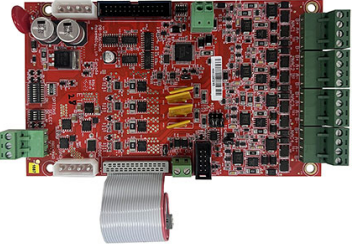
Table 1: FX-MNS-6000 System Components (Continued)



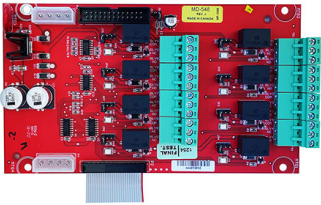
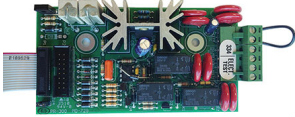
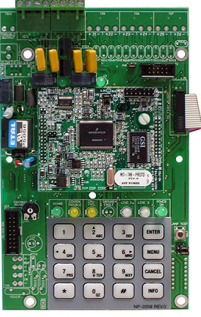

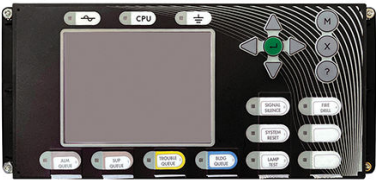
Model	Description
	<p>IPS-4848DS</p> <p>Programmable Input Switches Module (mounts in the BBX-FXMNS-6000 backbox and can also be part of the RAXN-4000LCD)</p>
	<p>IPS-2424DS</p> <p>Programmable Input Switches Module (mounts in the BBX-FXMNS-6000 backbox and can also be part of the RAXN-4000LCD)</p>
	<p>RAM-1032TZDS</p> <p>Main Chassis Remote Annunciator with 16 Bi-coloured LEDs and 32 trouble LEDs</p>
	<p>RAX-1048TZDS</p> <p>Adder Annunciator Chassis with 48 Bi-coloured LEDs and 48 trouble LEDs</p>
	<p>QMP-6101NV</p> <p>Network Master Paging Control Panel (Vertical Mount) mounts in the BBX-FXMNS-6000 backbox</p>
	<p>QMP-6101N</p> <p>Network Master Paging Control Panel (Horizontal Mount) mounts in the BB-5008 and BB-5014</p>

Table 1: FX-MNS-6000 System Components (Continued)



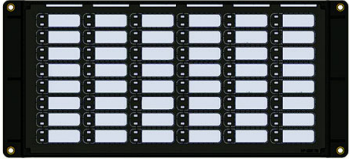
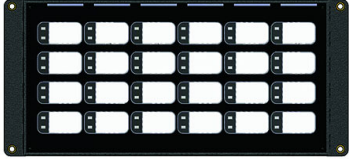
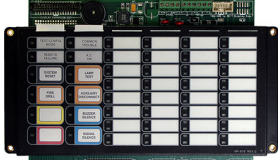

Model	Description
	<p>QMT-5302NV</p> <p>Network Master Telephone Control Panel (Vertical Mount) mounts in the BBX-FXMNS-6000 backbox</p>
	<p>QAZT-5302DS</p> <p>Addressable Telephone and Paging Selector Panel mounts in the BBX-FXMNS-6000 backbox</p>
	<p>QAZT-5348DS</p> <p>Addressable Telephone and Paging Selector Panel mounts in the BBX-FXMNS-6000 backbox</p>
	<p>QAD-6425-70</p> <p>70V Amplifier, maximum four speaker zones</p>
	<p>QAD-6425-25</p> <p>25V Amplifier, maximum four speaker zones</p>
	<p>BBX-FXMNS-6000 Fire Alarm and Audio Enclosure (red door with window/ black backbox)</p> <p>Enclosure 45.85"H x 22.4"W x 9.33"D</p>

Table 1: FX-MNS-6000 System Components (Continued)

Model	Description
	<p>QBB-6001 Expansion Audio Enclosure (full red door/black backbox)</p> <p>Enclosure 45.85"H x 22.9"W x 10.03"D</p>
	<p>RAXN-4000LCD</p> <p>Remote Shared Display Annunciator. Please refer to LT-895MP RAXN-4000LCD manual for further information</p>
	<p>RAXN-4000LCDG</p> <p>Remote Shared Graphical Display Annunciator. Please refer to LT-6033MP RAXN-4000LCDG manual for further information</p>
	<p>RAXN-4000LCDGC</p> <p>Remote Shared Graphical Color Display Annunciator. Please refer to LT-6738MP RAXN-4000LCDGC manual for further information</p>
	<p>MGD-32</p> <p>Master Graphic Driver Annunciator Board</p>
	<p>AGD-048</p> <p>Adder Graphic Driver Board</p>

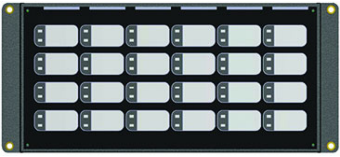
Table 1: FX-MNS-6000 System Components (Continued)

	Model	Description
	BAT-12V18A BAT-12V26A BAT-12V33A BAT-12V42A BAT-12V55A BAT-12V75A BAT-12V80A	Batteries available from 18 to 80 Ah Batteries larger than 55 Ah will fit into a BC-160(R) battery cabinet
MP-300R/S		End-of-line Resistor Plate, R for red, S for stainless steel finish
BC-160(R)		External Battery Cabinet (ULC and UL listed)

3.0 Installation

This chapter describes the installation of the BBX-FXMNS-6000 enclosure and the QBB-6001 enclosure.

3.1 BBX-FXMNS-6000 Enclosure Installation

This enclosure holds the FX-6000MNS-CH chassis with FleX-Net™ FX-4000 main fire alarm board and adder modules, the QMP-6101NV vertical mounting master paging microphone and the QMT-5302NV Master Telephone panels. The BBX-FXMNS-6000 enclosure includes a backbox, an inner door and an outer door.

Figure 3 BBX-FXMNS-6000 Enclosure

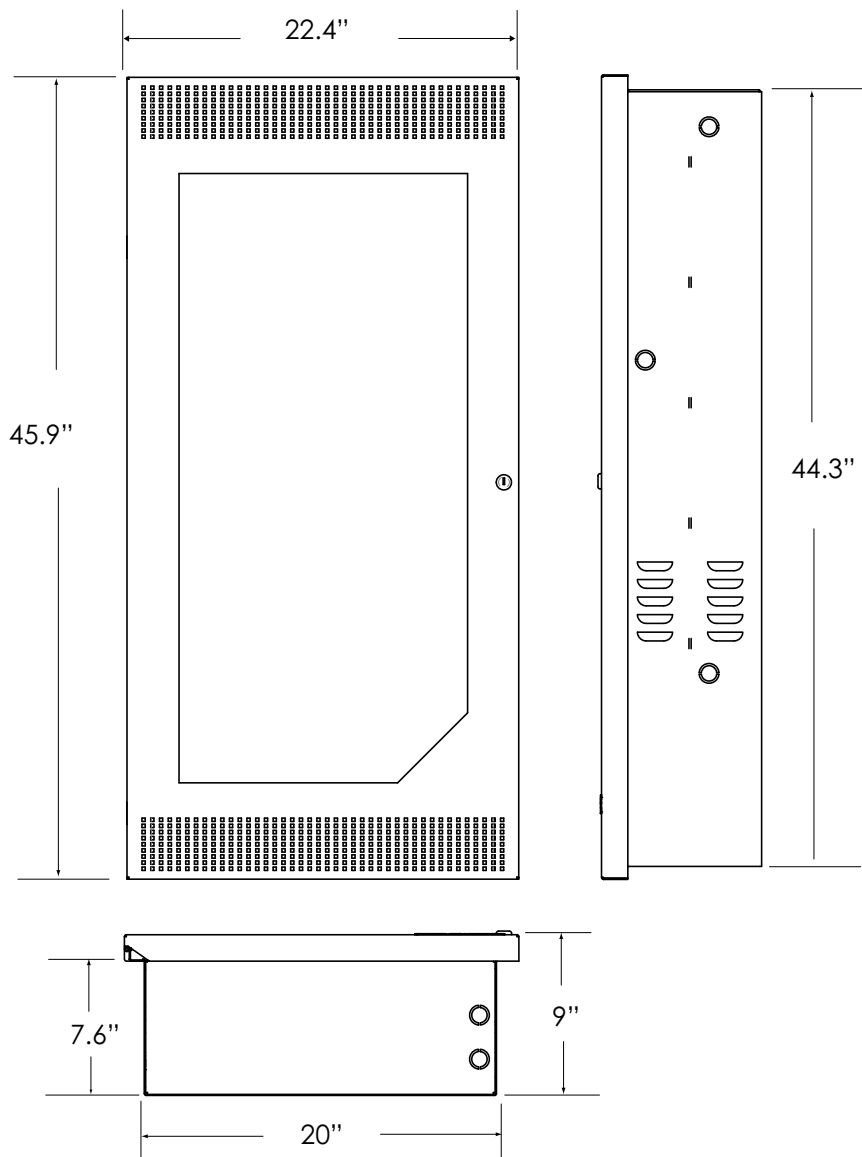
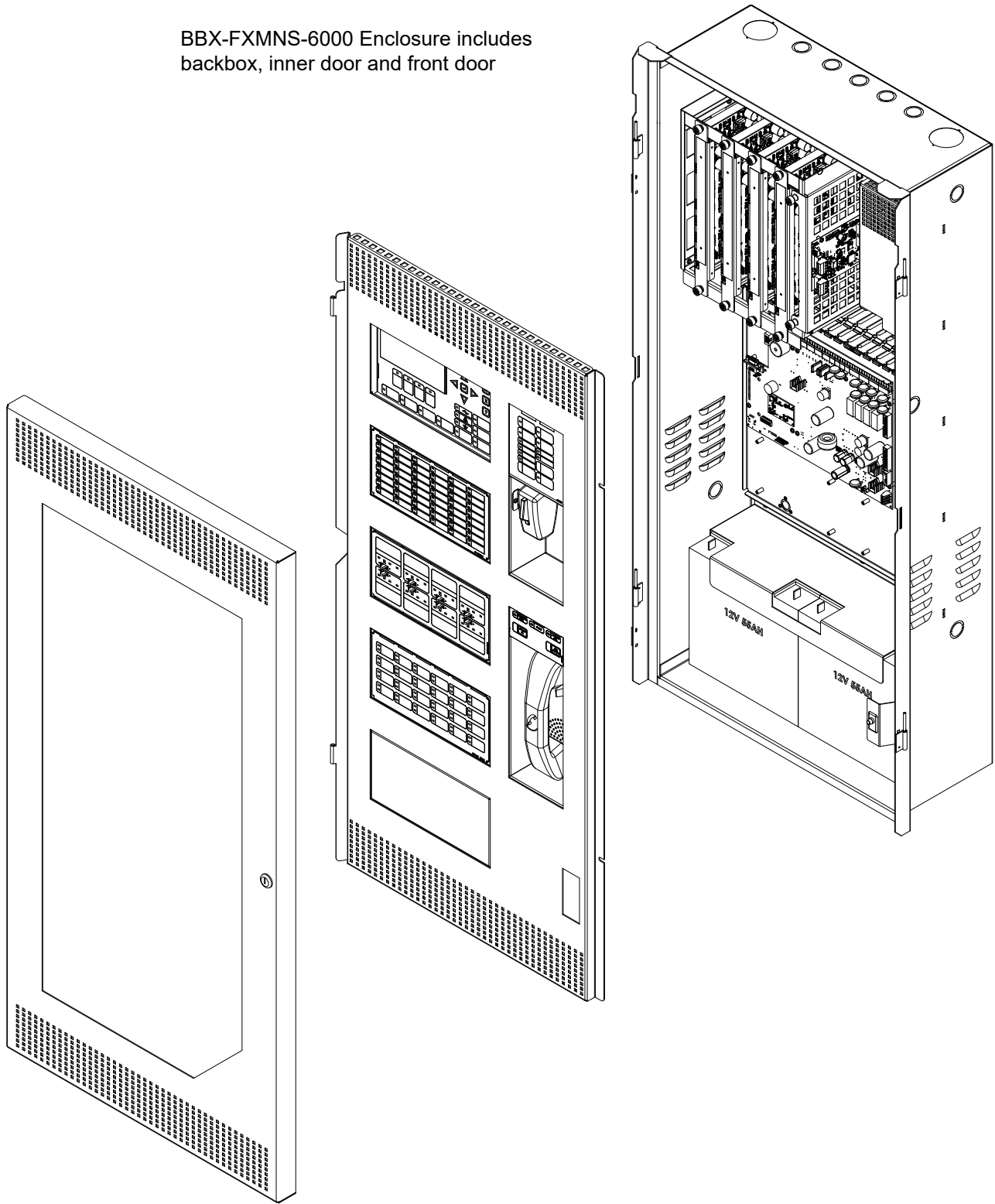

Figure 4 BBX-FXMNS-6000 Enclosure Complete View

BBX-FXMNS-6000 Enclosure includes
backbox, inner door and front door



3.1.1 FX-6000MNS-CH Main Fire Alarm Chassis

The chassis mounts into the BBX-FXMNS-6000 enclosure (backbox) as shown in Figure 5.

3.1.2 QMB-6000 Amplifier Card Cage

The QMB-6000 amplifier card cage mounts into the BBX-FXMNS-6000 enclosure as shown in Figure 5.

The BBX-FXMNS-6000 enclosure supports the QMB-6000 amplifier card cage which holds up to four amplifiers, 1 QCC-6000, the fire alarm main board chassis and QPS-6650 power supply.

Figure 5 BBX-FXMNS-6000 Backbox Dimensions and Contents

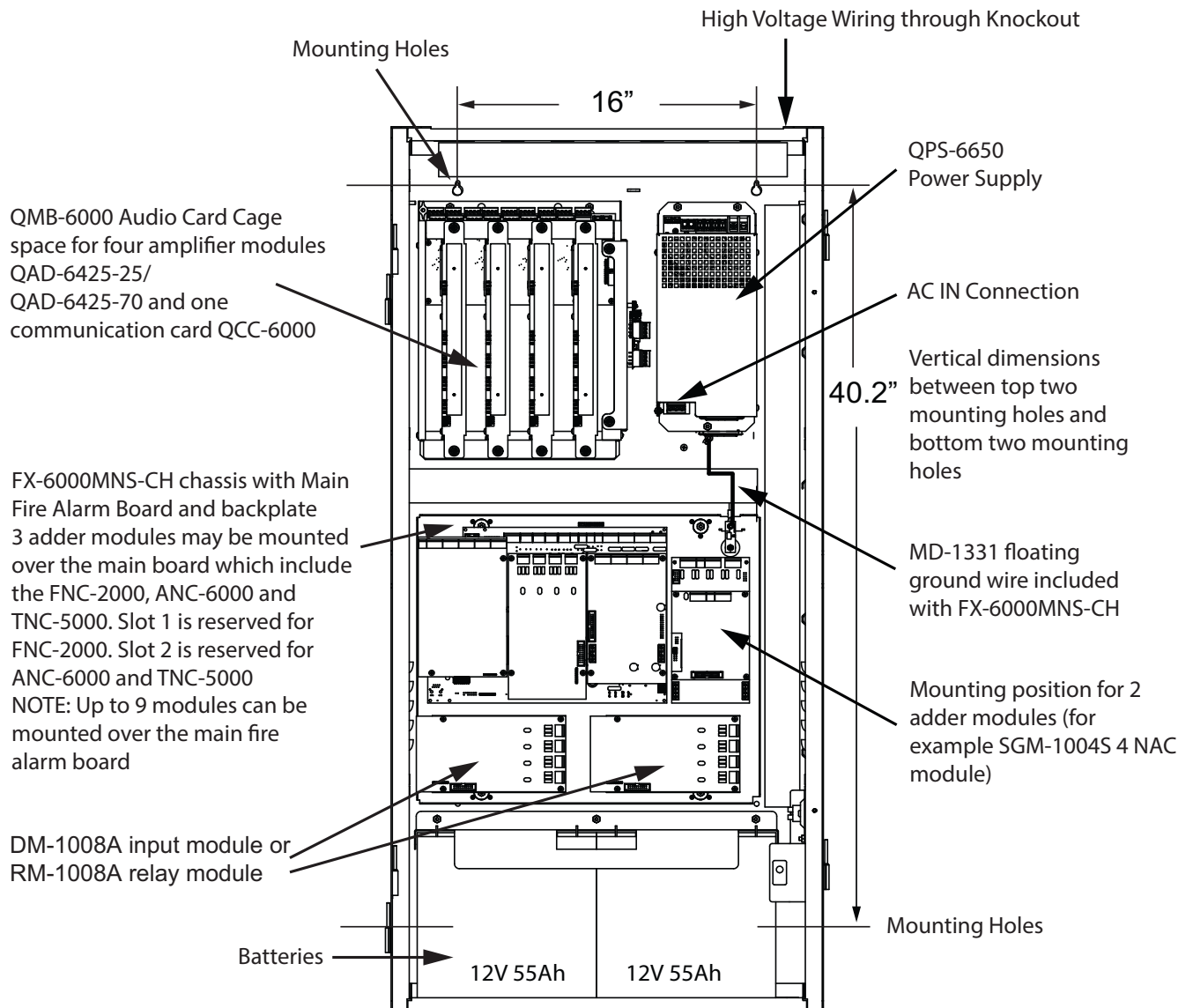

3.1.3 QMP-6101NV Master Paging Microphone and QMT-5302NV Master Telephone

The QMP-6101NV and QMT-5302NV are mounted on the inner door of the BBX-FXMNS-6000 enclosure. Refer to Figure 6.

Figure 6 BBX-FXMNS-6000 Inner Door

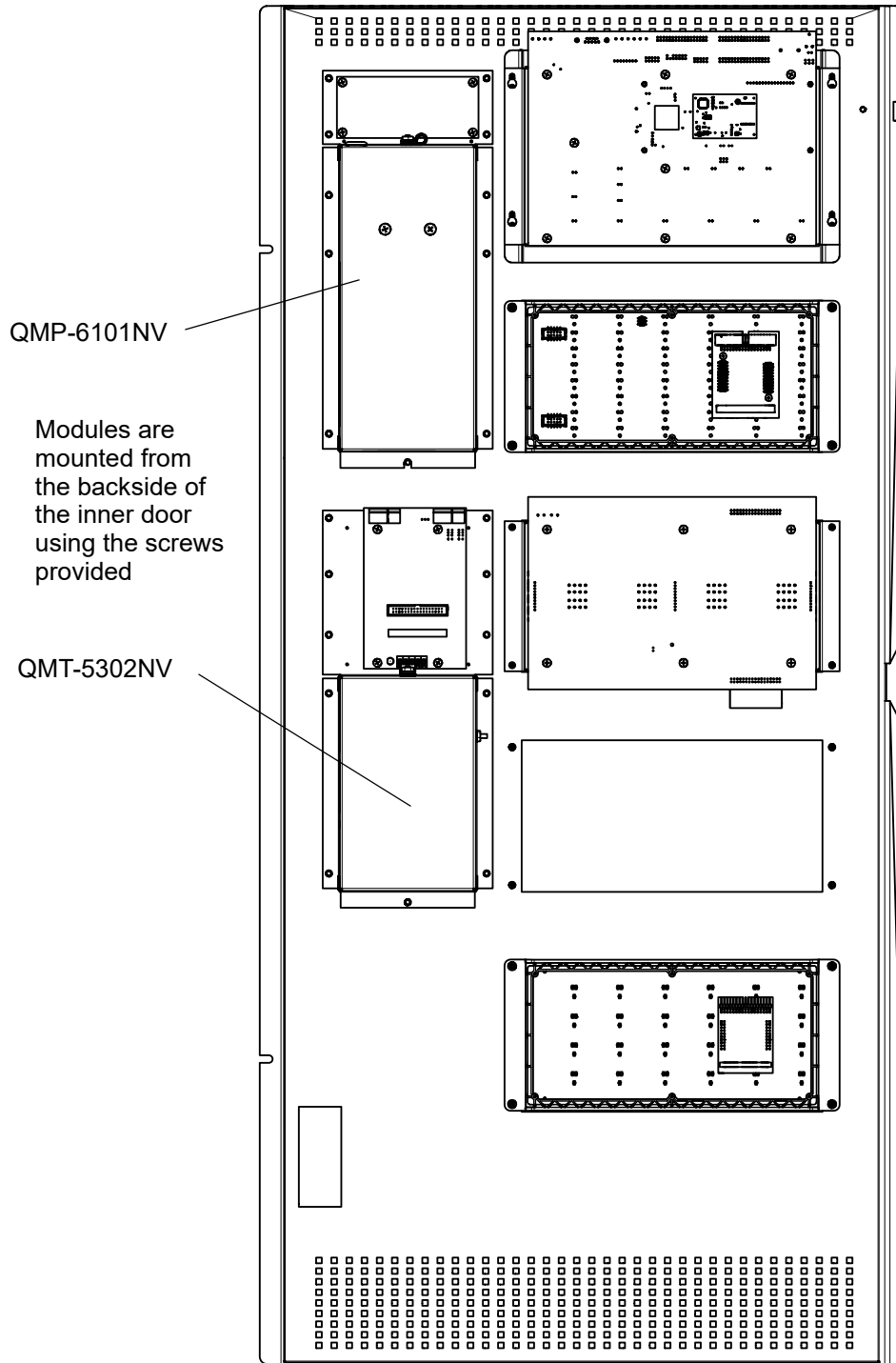

3.2 QBB-6001 Expansion Audio Cabinet Installation

The QBB-6001 expansion audio cabinet may be surface mounted only. The QBB-6001 consists of the backbox and door. Install all cabinets and enclosures empty. Pull all required wiring in through the conduit holes provided (must be punched out). Do not mount the modules until mechanical installation is complete and all wires have been fed into the cabinets and enclosures.

Figure 7 QBB-6001 Dimensions, Mounting Holes and Knockouts for Installation

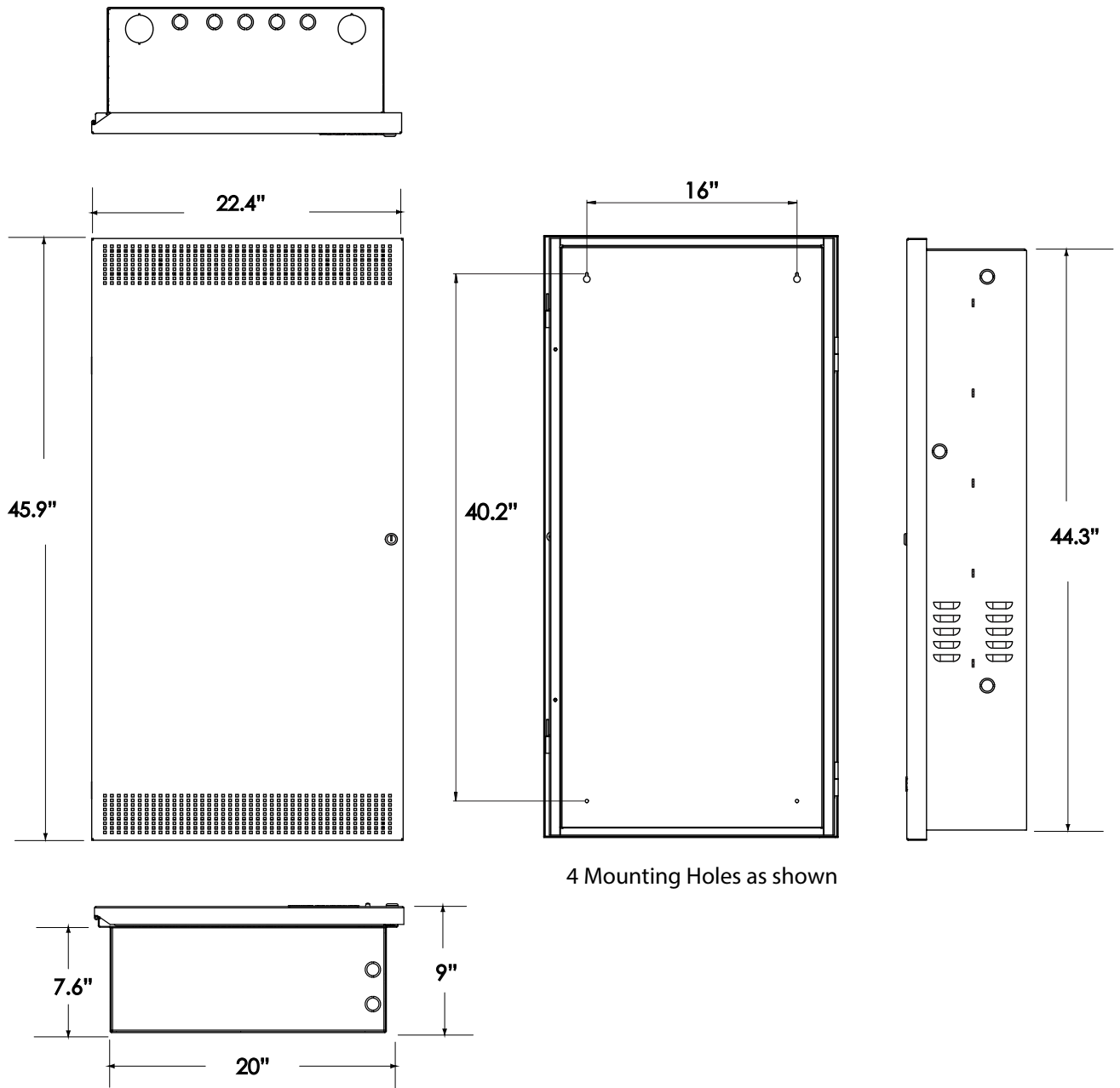

Note: It is extremely important to connect the audio cabinets earth-ground point (chassis ground) to the earth ground. Conduits should be brought in only through the conduits provided at both sides of the backbox.

3.3 QBB-6001 Enclosure

The QBB-6001 expansion audio cabinet includes the QPS-6650 Power Supply, and up to two QMB-6000 Card cages.

Up to eight Amplifier Modules QAD-6425-25/QAD-6425-70 may be installed into two QMB-6000 card cages. The total maximum wattage per expansion audio cabinet is 575 watts.

Figure 8 QBB-6001 Expansion Audio Cabinet Module Placement

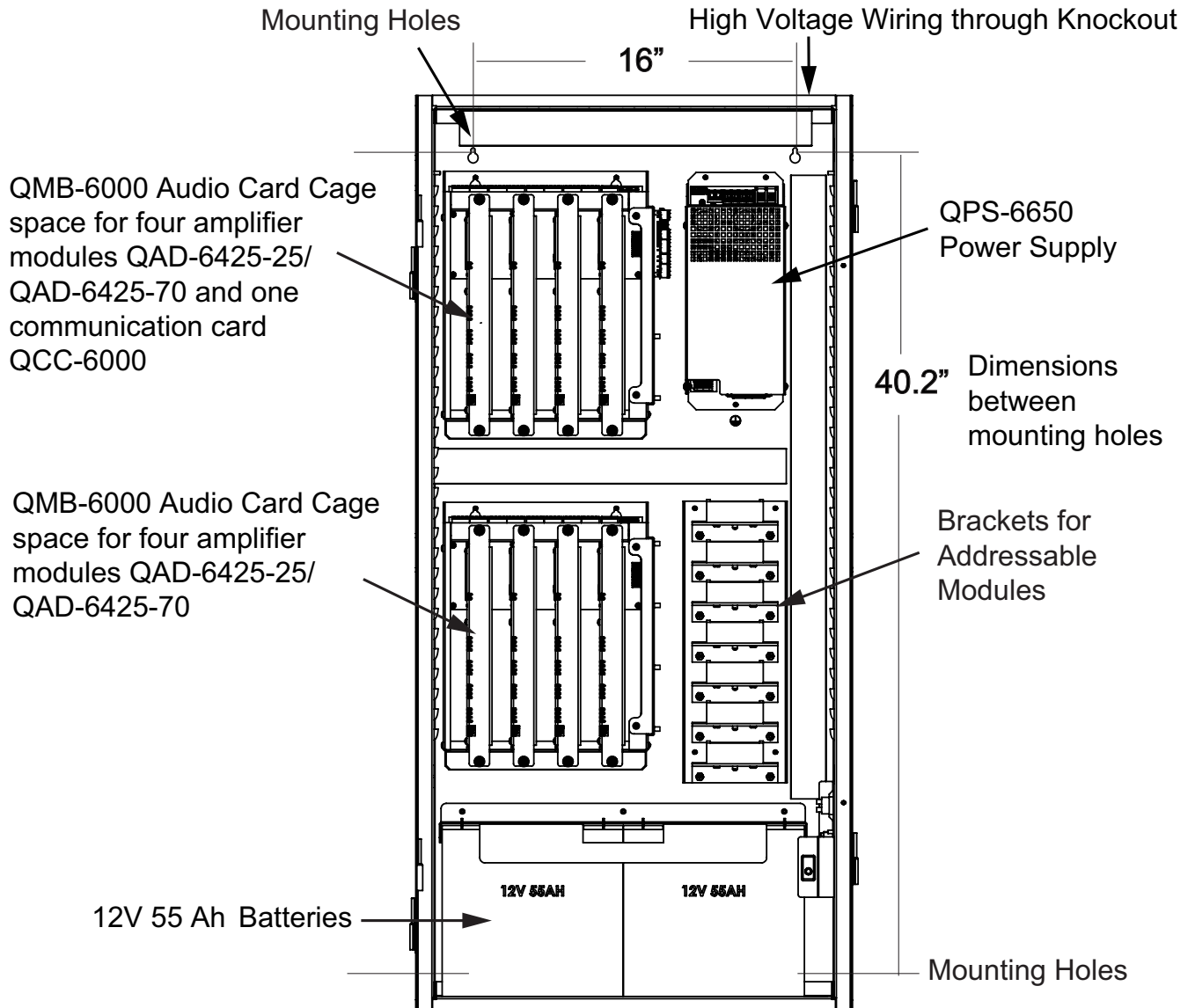

3.4 Display Modules

Each display module occupies one display position. These modules are mounted in the BBX-FXMNS-6000 enclosure which has cutouts (with brackets) on the inner door. A frame is a measure of display capacity, used in the programming of the system.

DSPL-420DS
Narrow Display Control
(2 Frames)

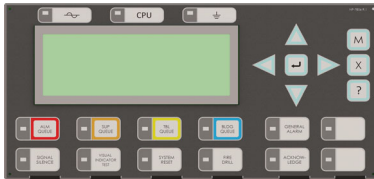

DSPL-2440DS
Graphic Display Control
(2 Frames)



FDX-008W(KI) Fan Damper Module
(1 Frame)



RAM-1032TZDS
Programmable Zone LED
Annunciator Module (2 Frames)



RAX-1048TZDS
Programmable Zone/Trouble
LED Annunciator Module
(3 Frames)

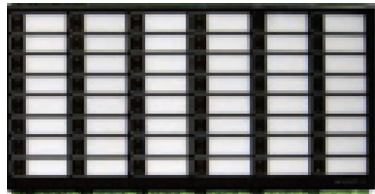

IPS-2424DS
Programmable Input
Switches Module (2 Frames)

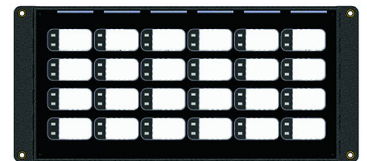

IPS-4848DS
Programmable Input
Switches Module (4 Frames)

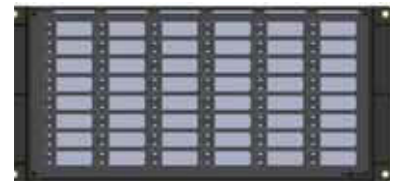

4.0 Module Settings

4.1 Main Fire Alarm Module (MD-871A “N” Version Main Chassis)

This main board has network capability.

- JW1** Jumper is removed if a PR-300 or UDACT-300A is installed.
- JW2, JW4** Jumpers are Factory Set and should not be changed.
- JW5** Normally un-installed, add jumper to silence on-board buzzer.
- JW6** Normally installed, remove jumper to enable external power supply supervision.
- P1, P2** Factory connection to QPS-6650.
- P3** Black RS-485 Connector connects to the Adder Loop ALCN-4792MISO if used (Address Loops 3 and 4) or ALCN-960MISO (Address Loop 3 and 4).
- P4** Connector for PR-300 Module or UDACT-300A.
- P5** Connector for next 8 Conventional Hardwire Circuit Adder Modules (Loop 1).
- P6** Connector for first 8 Conventional Hardwire Circuit Adder Modules (Loop 0).
- P7** Ethernet jack.
- P8** Power Connector for Adder Modules.
- P9** RS-232C for Printer or laptop.
- P10, P11** Not used.
- P14** Connector for Display Module.
- P15, J1** Connectors for Factory Use.
- P16** High speed RS-485 audio link to ANC-6000 Audio Network Controller Module. When connected provides ARCnet or Fiber Optic audio and telephone communication.
- P19** Connector for FNC-2000 Fire Network Controller Module.
- SW2** DIP Switch for node address.
- NAC PWR** 24V FWR input terminals for additional power for signal adder modules.
- F1** 20 ampere slow blow non-replaceable fuse.



Note: To enable communication from the Main Module to all of the Adder Modules, it is necessary to add a Continuity Jumper on the last Adder Module in a chain (see the appropriate Module Settings section to verify the location of the Continuity Jumper on a particular Circuit Adder Module). Only the last circuit adder module should have a jumper plug on its continuity jumper; all others must be left without a jumper plug.

TO CONFIGURE THE FIRE ALARM PANEL USE THE RS-485 CONNECTOR P4 OF THE LAST ADDER LOOP CONTROLLER MODULE INSTALLED OR IF NOT PRESENT, P3 ON THE Flex-Net™ FX-4000 MAIN FIRE ALARM MODULE.

Figure 9 Main Fire Alarm Module (MD-871A”N” Version Main Board.

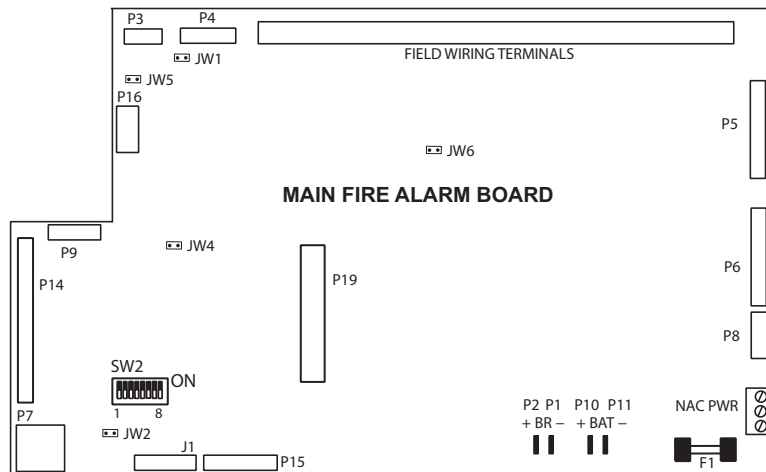

4.1.1 SW2 DIP Switch Node Address Setting on Main Fire Alarm Module

Refer to Appendix C for Node Address Setting. Available addresses are 1 to 63. DIP Switch SW2-1 is the least significant digit.

4.2 DSPL-420DS Main Display Module

The DSPL-420DS mounts onto inner door of the BBX-FXMNS-6000. This display is part of the following main fire alarm chassis: FX-6000MNS-CH.

Figure 10 DSPL-420DS Main Display Module (Part of Main Chassis c/w Main Fire Alarm Module)

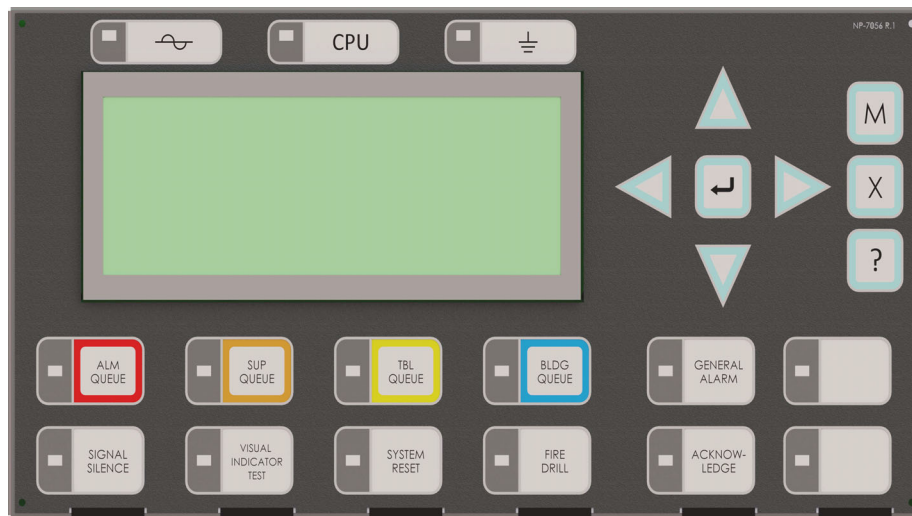

P1: Cable connects to P14 of the main fire alarm board (Figure 9).

P2: Connection to P1 of any adder display module if used.



Note: The main display module comes with slide-in paper labels including both English and French slide-ins, and laser printer-compatible blanks for zone labelling.

4.3 DSPL-2440DS Graphical Main Display Module

The DSPL-2440DS is a separate item. It can be mounted onto the inner door of the BBX-FXMNS-6000. It can replace the DSPL-420DS found with the model FX-6000MNS-CH.

Figure 11 DSPL-2440DS Graphical Main Display Module

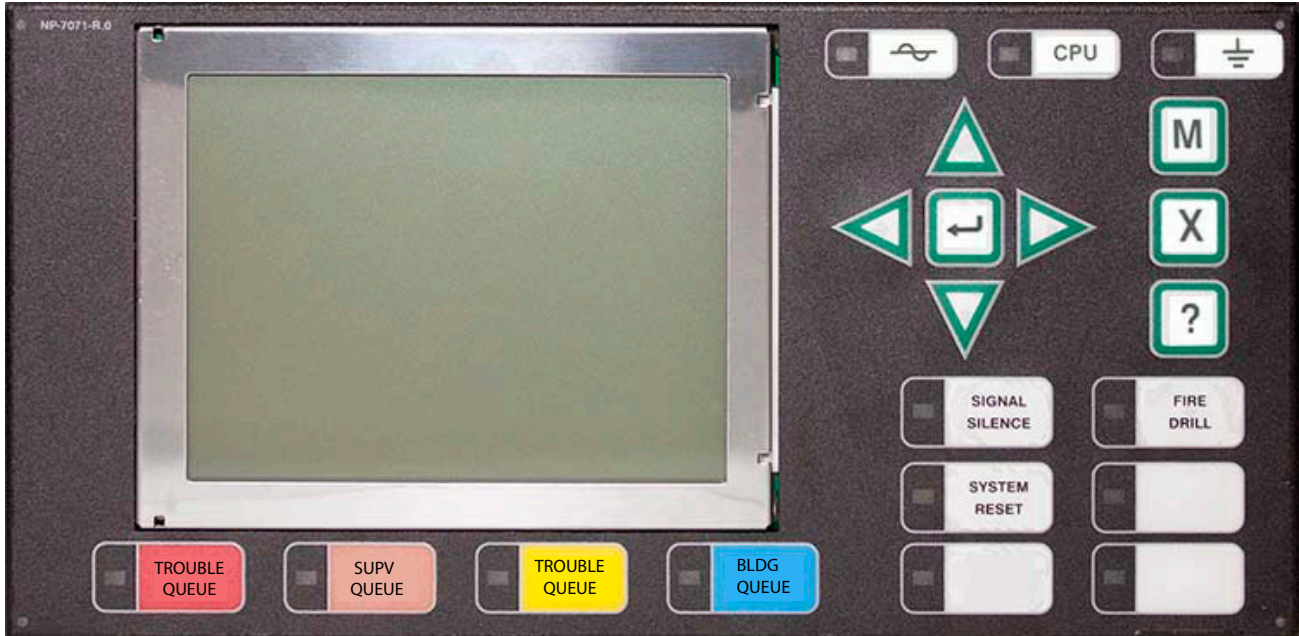

P1: Cable connects to P14 of the main fire alarm board (Figure 9).

P2: Connection to P1 of any adder display module if used.



Note: The main display module comes with slide-in paper labels including both English and French slide-ins, and laser printer-compatible blanks for zone labelling.

4.4 FNC-2000 Fire Network Controller Module

An FNC-2000 Fire Network Controller module is required in each fire alarm node in the system. The FNC-2000 also provides a connection for an optional FOM-2000-UM Fiber Optics Module.

Figure 12 FNC-2000 Fire Network Controller Module

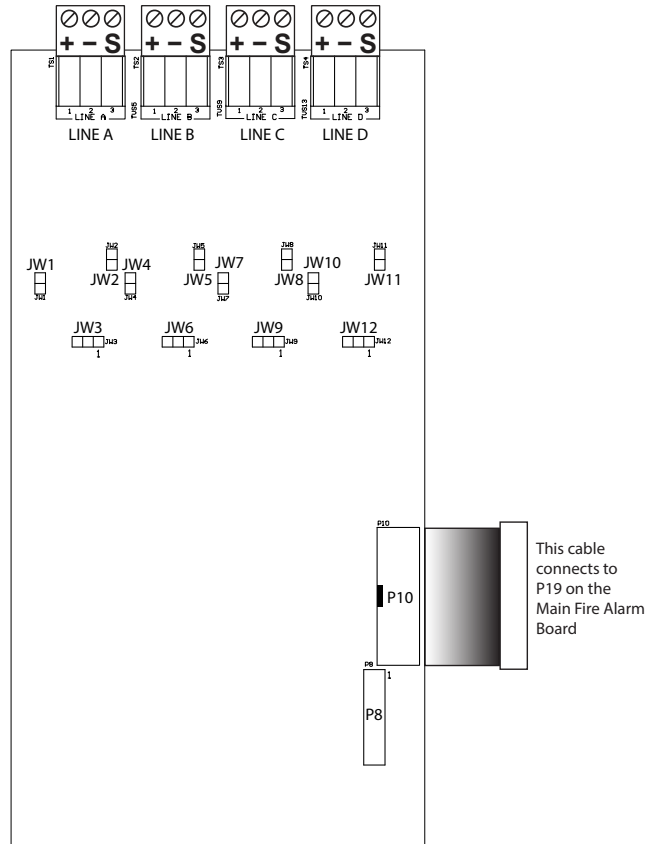

Table 2: FNC-2000 Module List of Connectors and Jumpers and Functions

Connector or Jumpers	Function
P8	Not used.
P10	Connects to P1 of the FOM-2000-UM Fiber Optic Network Adder Module if used.
JW1, JW2, JW4, JW7, JW8, JW11	Jumpers for JW1, JW4, JW7, and JW10 equal Line Termination (always short). Jumpers for JW2 and JW8 equal Ground Fault (always short).
JW5 and JW11	Leave both un-installed. Do not connect JW5 or JW11 (open).
JW3, JW6, JW9, JW12	Jumpers for JW3, JW6, JW9, JW12 are between pins 2 and 3 (far left). Leave as is.



Note: Network connection is through twisted cable from Line A, B, C and D. Refer to Figure 38 for specific wiring and cable information.

4.5 FOM-2000-UM Fiber Optic Network Module

Figure 13 FOM-2000-UM Fiber Optic Network Module

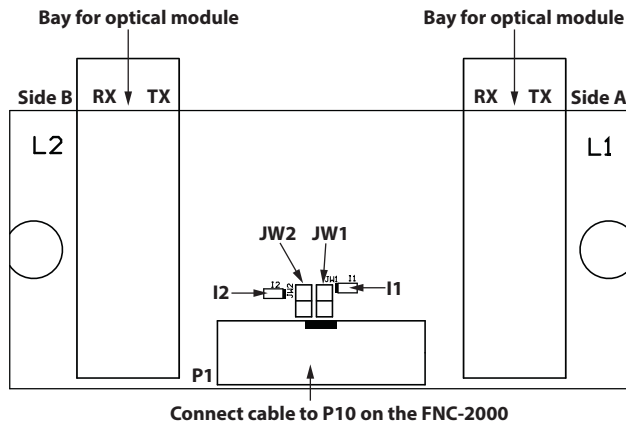

One of these modules is required at each panel where fiber optics will be used between them. The FOM-2000-UM is mounted over the FNC-2000 Network board (over the field wiring terminals) with two #6 Phillips screws and two Hex spacers.

Table 3: FOM-2000-UM Fiber Optic Network Module Cable Connection

Connector	Function
P1	Attaches to P10 of the FNC-2000 Fire Network Controller Module.
JW1	Must be on (closed) if an optical module is installed in L1. JW2 must be on (closed) if an optical module is installed in L2.
JW2	If there is no optical module in L1, remove the jumper from JW1 . If there is no optical module in L2, remove the jumper from JW2 .

4.6 RAX-1048TZDS Zone Display Module

Figure 14 Zone Display Module RAX-1048TZDS

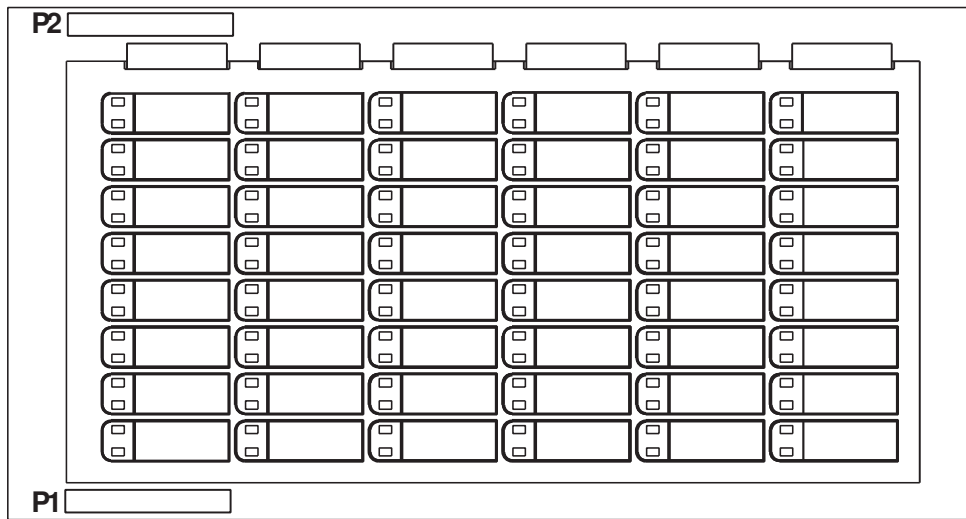

Table 4: RAX-1048TZDS Zone Display Module Cable Function

Connector	Function
P1	Connects to P2 of previous display module.
P2	Connects to P1 of next display module



Note: The zone display module comes with laser printer-compatible slide-in paper labels for zone labelling.

4.7 IPS-4848DS Programmable Input Switches Module

Figure 15 IPS-4848DS Programmable Input Switches Module

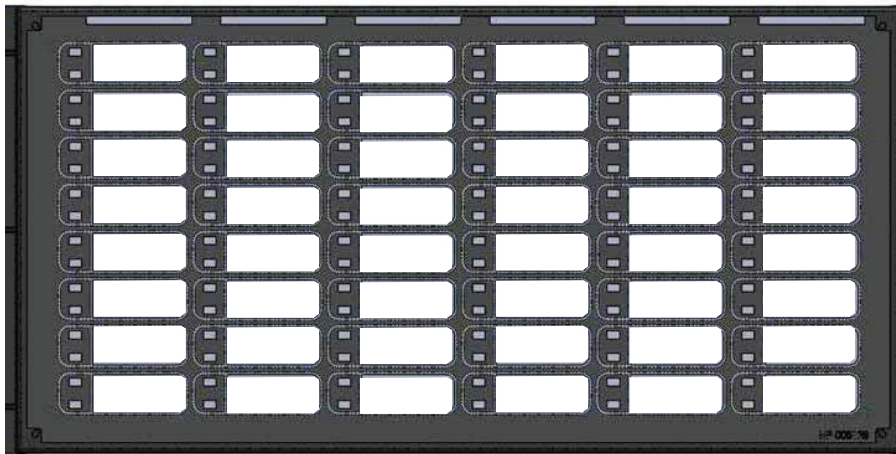

Figure 16 IPS-4848DS Wiring

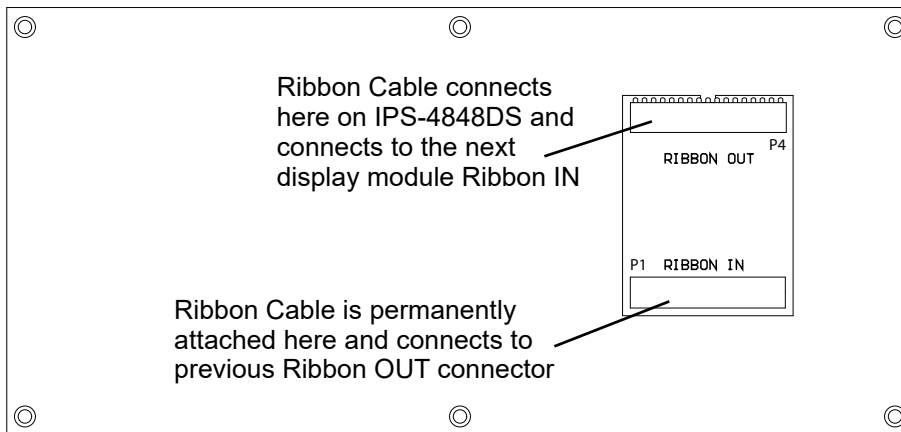

Table 5: IPS-4848DS Programmable Input Switches Module Cable Function

Connector	Function
P1	Connects to P2(or P4) of previous display module.
P4	Connects to P1 of next display module



Note: The IPS-4848DS module comes with laser printer-compatible slide-in paper labels for zone labelling.

4.8 IPS-2424DS Programmable Input Switches Module

The IPS-2424DS Programmable Input Switches Module provides 24 programmable switches, 24 bi-coloured (red/amber) LEDs for fire alarm zone annunciation and 24 amber trouble LEDs

Figure 17 IPS-2424DS Programmable Input Switches Module

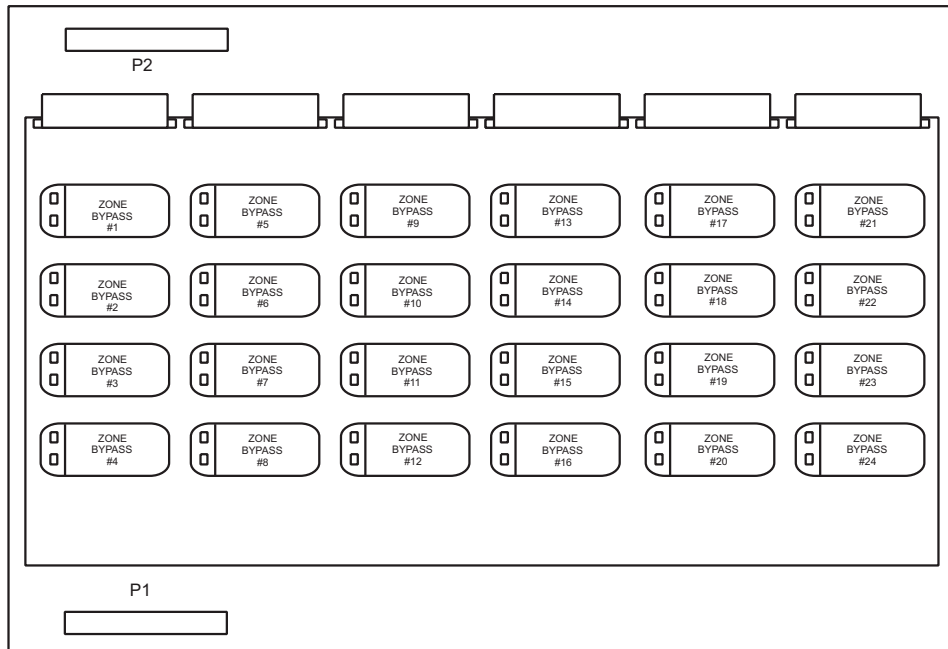

Table 6: IPS-2424DS Programmable Input Switches Module Cable Function

Connector	Function
P1	Connects to P2 of previous display module.
P2	Connects to P1 of next display module



Note: The IPS-2424DS module comes with laser printer-compatible slide-in paper labels for zone labelling.

4.9 FDX-008W(KI) Fan Damper Control Display Module

There are two models of the Fan Damper Control Display modules available. The FDX-008W provides switch control and LED indication of 8 fan damper zones. The FDX-008W(KI) provides switch control of 7 fan damper zones with the eighth zone activated by keyswitch. LED indication is provided for all 8 fan damper zones on the FDX-008W(KI). Both the FDX-008W and the FDX-008W(KI) are used in conjunction with a FleX-Net™ FX-4000 Fire Alarm Control Panel.

Figure 18 Fan Damper Control Display Module FDX-008W(KI)

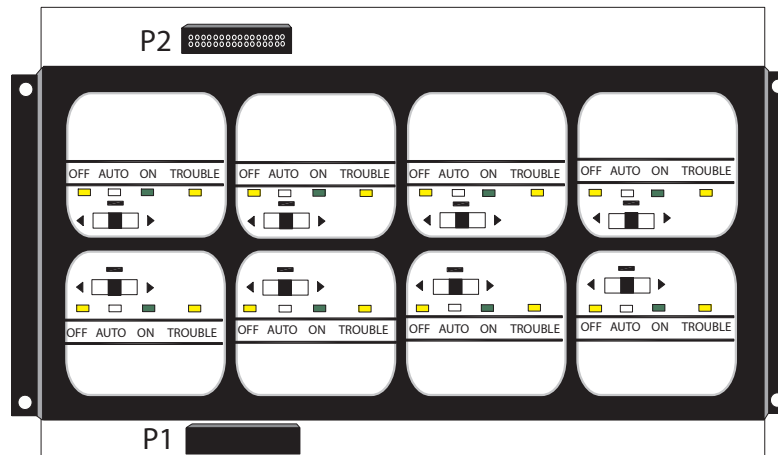

4.9.1 Fan Damper Operation

The FDX-008W Fan Damper Control Display module has eight configurable output circuits, each with a three position switch. The FDX-008W(KI) operates in the same manner as the FDX-008W except zone 8 is controlled by a remote keyswitch. Each switch has an ON and OFF position, plus an AUTO position. If the switch is placed in the AUTO position, the white AUTO LED will illuminate steady and the output will activate as programmed or configured. The output can be manually turned ON or OFF by placing the switch in the ON or OFF position, respectively.

Basically each switch can be configured to operate multiple fans or dampers. For each switch, there are 3 operations provided; outputs to turn ON, same outputs to turn OFF and inputs to bypass.

An example of the most common use of the FDX-008W or FDX-008W(KI) Fan Damper Control Display module is to operate exhaust fans and confirm fan operation (via monitor modules). See Figure 19 on the next page for a block diagram of fan and monitor set up.

4.9.2 Example

As shown in the figure to the right, Parking Garage #1 has 3 exhaust fans. The three position switch is configured to operate (to turn ON) fans 1, 2 and 3 in stairwell #1. The switch is set in the AUTO position (white AUTO LED on steady). Upon activation (via alarm or some other programmed trigger) with the switch in AUTO, the 3 fans (1,2, and 3) in stairwell #1 are turned ON automatically. Monitor modules in the Parking Garage #1 detect that all 3 fans are operating, therefore the ON LED will illuminate steadily. If one of the fans did not turn ON (due to malfunction), both the ON and OFF LEDs

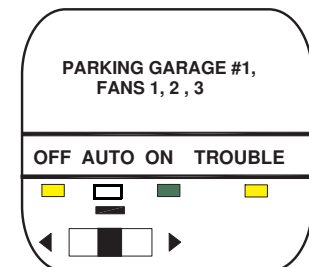

will flash at the slow trouble rate. The TRBL (trouble) LED will illuminate steady amber based on feedback from the monitor module that one or more of the fans is not working.

AUTO LED shows steady for switch in AUTO position.

ON LED shows steady for all outputs operating and confirmed.

OFF LED shows steady for all outputs NOT operating and confirmed.

TRBL LED shows steady for one or more outputs NOT operating and confirmed.



Note: A bypass function always has priority, so that if a circuit is bypassed by moving the switch manually or by loop bypass (FleX-Net™ FX-4000 Fire Alarm Panel), no other action will operate this switch other than again moving the switch manually or by un-bypassing the loop.

Figure 19 FDX-008W Block Diagram of Fan and Monitor Set-up

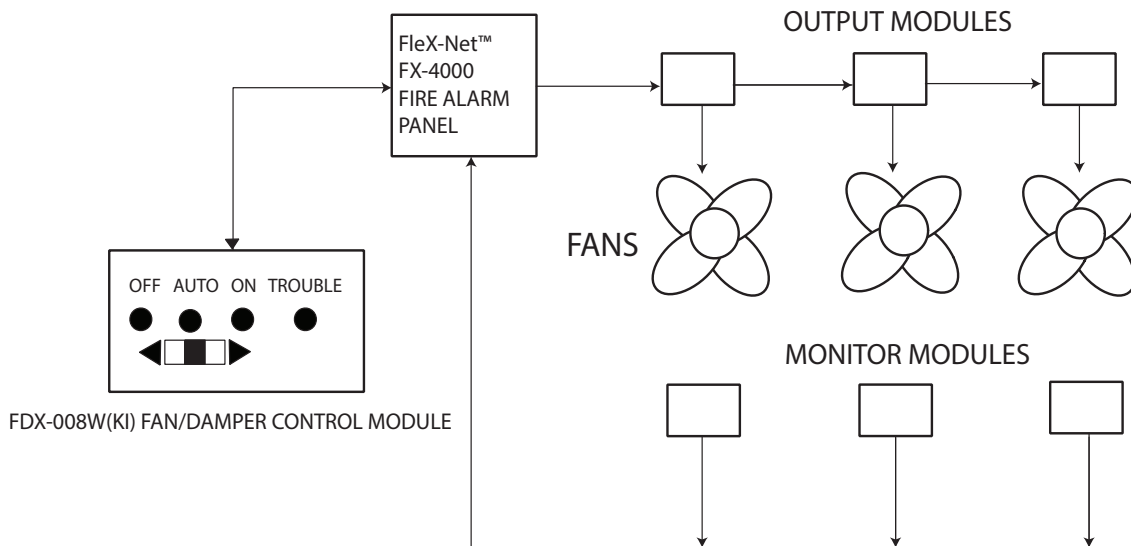

Before mounting the FDX-008WKI module, if a keyswitch is to be connected, wire the keyswitch to terminals at TS1 as shown in Figure 20 below. Mount the FDX-008W and FDX-008WKI Fan Damper Control Display modules in any position on the front part of the FleX-Net™ FX-4000 chassis and backbox.

Figure 20 FDX-008WKI Fan Damper Control Display Module

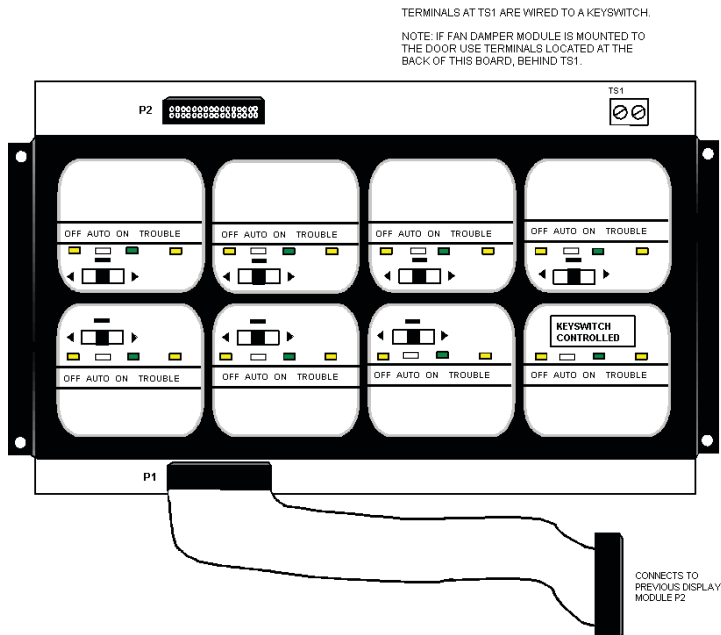

Note: There are also terminals located behind TS1 on the other side of the board for the convenience of wiring the keyswitch. The last fan damper zone in the bottom right position of the FDX-008WKI is controlled by the keyswitch

4.9.3 UUKL with FDX-008W and FDX-008WKI

The models FDX-008W and FDX-008WKI can be effectively used to provide an automatic and manual control system for smoke. Refer to document number LT-966 for extensive instructions regarding UUKL applications.

4.10 DM-1008A Hardwire Detection Adder Module

Figure 21 Hardwire Detection Adder Module DM-1008A

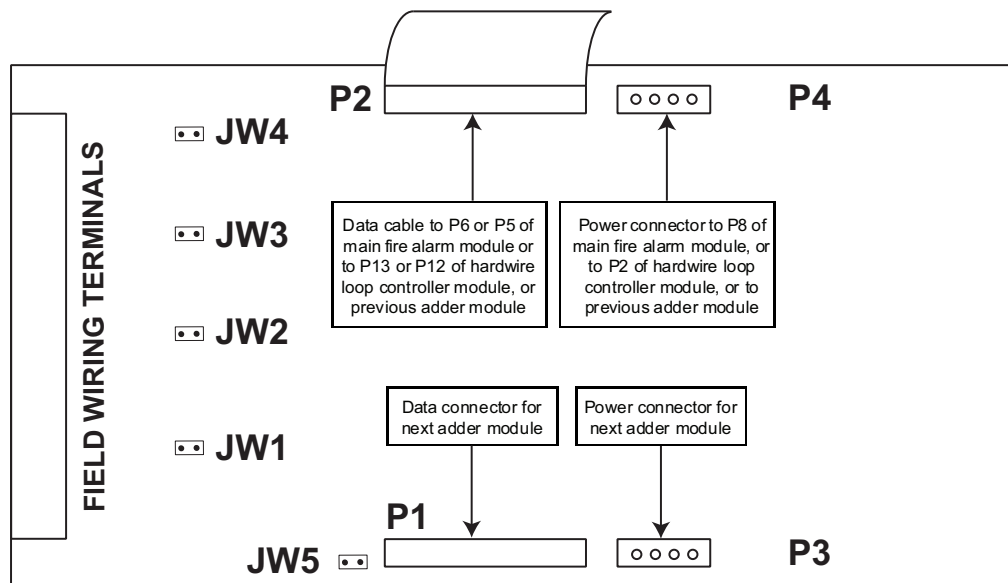

JW1: Install jumper for Class A operation of initiating circuits 1 and 2.

JW2: Install jumper for Class A operation of initiating circuits 3 and 4.

JW3: Install jumper for Class A operation of initiating circuits 5 and 6.

JW4: Install jumper for Class A operation of initiating circuits 7 and 8.

JW5: Remove continuity jumper if there are any more adder modules installed.



Note: For Class A operation the FleX-Net™ FX-4000 must be configured as Class A via the configuration program.

4.11 SGM-1004A Hardwire Signal Adder Module

Figure 22 Hardwire Signal Adder Module SGM-1004A

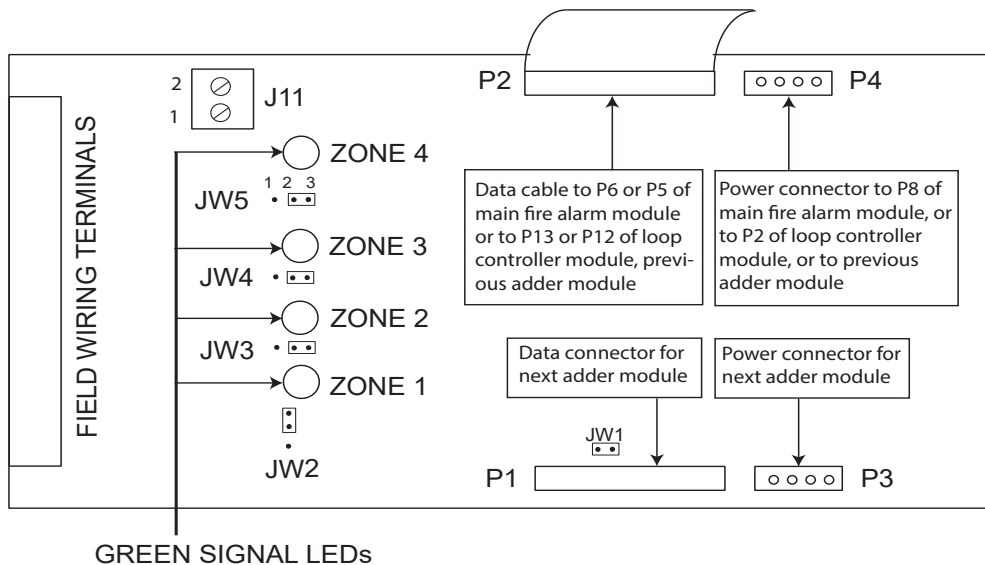

4.11.1 Basic Mode

Jumpers on the SGM-1004A Signal Adder Module and their functions:

JW1: Remove continuity jumper if this is not the last adder module installed.

JW2, JW3, JW4, and JW5: Leave these jumpers open, on positions 2 and 3.

J11 Terminals: Not connected.

Components

There are four green LEDs on the board, one for each signal zone. The LED will illuminate or flash following the signal rate sent to its zone. It will be off when the system is normal and they will illuminate when a signal zone is activated. The LED does not reflect what is happening on the signal zone, just that it is receiving data to activate that signal zone.



Note: Jumpers JW2, JW3, JW4 and JW5 are positioned on pins 2 and 3 (right two pins with board orientation as shown above) from factory.

Operation

There are two modes of operation for this module. The basic mode of operation does not involve any isolators connected to the signal zones. For this case, leave jumpers JW2, JW3, JW4 and JW5 as they come on pins 2 and 3, and do not make any connection to terminal block J11. The second mode is used when isolators are to be connected to the signal circuits. For further information on bell cut relays or isolators, please refer to the specific fire alarm panel manual or the isolator instruction manual.

4.11.2 Isolator Mode

Jumpers for the Isolator Mode

JW2: Place jumper over pins 2 and 3 for the ability to connect an isolator on Zone 1.

JW3: Place jumper over pins 2 and 3 for the ability to connect an isolator on Zone 2.

JW4: Place jumper over pins 2 and 3 for the ability to connect an isolator on Zone 3.

JW5: Place jumper over pins 2 and 3 for the ability to connect an isolator on Zone 4.



Attention: Discard jumpers on zones that are not configured for isolators.

J11: Wire these terminals to an alarm relay. These may be tapped if more signal modules are used in this manner.

4.12 SGM-1004S 4 NAC Output Module with Built-in Sync

Figure 23 Signal Adder Module SGM-1004S

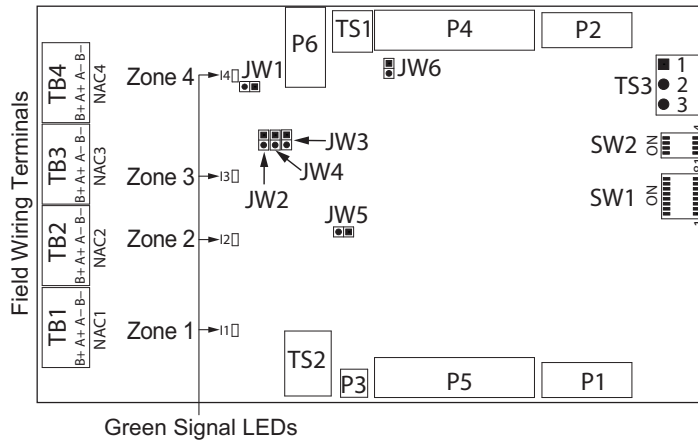

Table 7: SGM-1004S Terminal and Jumper Descriptions

Component	Description
TB1 - TB4	Field wiring terminals
TS1	Connect to an alarm relay (see section 4.12.9) or to a bell cut relay (see section 4.12.8)
TS2	Connect to an output for signal silence (see section 4.12.10)
TS3	The default is pins 2 and 3 closed. Do not change
P1	Power cable to next adder module
P2	Power cable to P8 on FACP main board or to previous adder module
P3	Factory use only
P4	Data cable to P6 on FACP main board or to previous adder module
P5	Data cable to next adder module
P6	Factory use only
JW1 - JW4	Jumpers for Suite Isolator Mode. See section 4.12.9
JW5	Watchdog jumper (normally closed)
JW6	Continuity jumper. Closed if this is the last adder module. Remove this jumper if this is not the last adder module installed
SW1	See section 4.12.2 below
SW2	See section 4.12.3 below

4.12.1 LEDs

There are four green LEDs (labeled I1, I2, I3, I4) on the board, one for each signal zone. The LED illuminates or flashes following the signal rate sent to its zone. It is off when the system is normal and it illuminates when a signal zone is activated. The LED does not reflect what is happening on the signal zone, just that it is receiving data to activate that signal zone.

4.12.2 DIP Switch 1

Table 8: SGM-1004S DIP Switch 1

	SW1	SW2	SW3	SW4	SW5	SW6	SW7
No sync	OFF	OFF	OFF	OFF			
Mircom/Amseco	ON	OFF	OFF	OFF			
Secutron/Gentex	OFF	ON	OFF	OFF			
System Sensor	OFF	OFF	ON	OFF			
Wheelock	OFF	OFF	OFF	ON			
No function					OFF	OFF	
Signal silence					ON	OFF	
No function							OFF
Bell Cut							ON

Note: Leave SW6 and SW8 OFF.

4.12.3 DIP Switch 2: Bell Cut Select

Table 9: SGM-1004S Bell Cut Select

DIP switch 2	SW1	SW2	SW3	SW4
None	OFF	OFF	OFF	OFF
NAC 1	ON	-	-	-
NAC 2	-	ON	-	-
NAC 3	-	-	ON	-
NAC 4	-	-	-	ON

4.12.4 Field Wiring

See section 5.5.2.

4.12.5 Synchronization

Use DIP Switch 1, SW1 to SW4, to set the SGM-1004S to no sync (the panel provides synchronization) or to sync according to a manufacturer's protocol.

If the panel is set to Temporal 3, and the DIP Switch 1 is set to **No sync**, then the field wiring terminals are **not power-limited**. All the field wiring terminals on each SGM-1004S must be either all power-limited or all non-power-limited.

If DIP Switch 1 is set to a manufacturer protocol, then the field wiring terminals are **power-limited**.

Attention: If the field wiring terminals are power-limited, attach the included label NP-8308 to the field wiring terminals.
If the field wiring terminals are not power-limited, discard the included label NP-8308.

Maintain a separation of 1/4" (6.4 mm) minimum between power-limited and non-power-limited wiring at all times. Reserve the left side of the enclosure for all non-power-limited wiring.



4.12.6 Operation

There are four modes of operation for this module.

4.12.7 Basic Mode

The basic mode of operation does not involve any bell cut relay or suite isolators connected to the signal zones, and no signal silence. For this case, leave jumpers JW1, JW2, JW3 and JW4 off, leave SW5, SW6 and SW7 of DIP Switch 1 off, leave the switches of DIP Switch 2 off, and do not connect anything to terminal blocks TS1 or TS2.

4.12.8 Bell Cut Mode

This mode provides bell cut operation which allows the silencing of bells or horns.

1. Connect TS1 to a bell cut relay (for details see *LT-666 QRM-1001 Bell Cut Module Installation and Operating Instructions*).
2. Set SW7 of DIP Switch 1 ON.
3. Use DIP Switch 2 to select which of the four NACs will silence its bells and horns when the bell cut relay is active. You can select more than one NAC.

4.12.9 Suite Isolator Mode

This mode is used when suite isolators are connected to the signal circuits.

1. Connect TS1 to a common alarm relay. See Figure 24.
2. Set SW7 of DIP Switch 1 OFF.
3. Place a jumper according to Table 10.

Table 10: Jumpers for Suite Isolator Mode

Place jumper on	JW1	JW2	JW3	JW4
If there is a suite isolator on	zone 1	zone 2	zone 3	zone 4



Attention: Discard jumpers on zones that are not configured for suite isolators.

Refer to *LT-875 CSIS-202A Supervised Signal Isolator Module Installation Instructions* or *LT-879 CSIS-202A1 Supervised Signal Isolator Module Installation Instructions*.

For further information on bell cut relays or suite isolators, please refer to the specific fire alarm panel manual or the isolator instruction manual.

Figure 24 Suite Isolator Mode Wiring

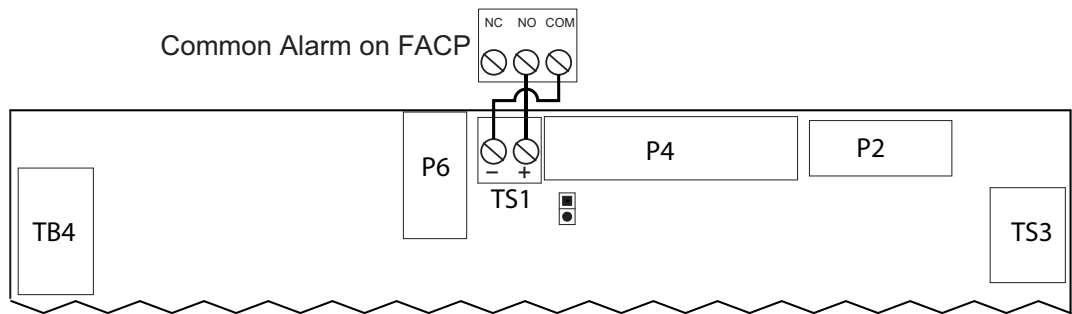

4.12.10 Signal Silence Mode

This mode is used if audible signals are required to be silenced but visual signals should continue to function when signal silence is activated on the panel.

1. Connect TS2 to a NAC output that is configured as a continuous silenceable signal (not strobe). See Figure 25.
2. Configure the NACs on the SGM-1004S that require horns to be silenced as non-silenceable strobes using the panel configurator.
3. Set DIP switch 1 for the strobe manufacturer (see section 4.12.2).
4. Set SW5 of DIP Switch 1 ON.

When signal silence is active, the SGM-1004S changes its output signals from both horns and strobes active to only the strobes active.

Figure 25 Signal Silence Mode Wiring

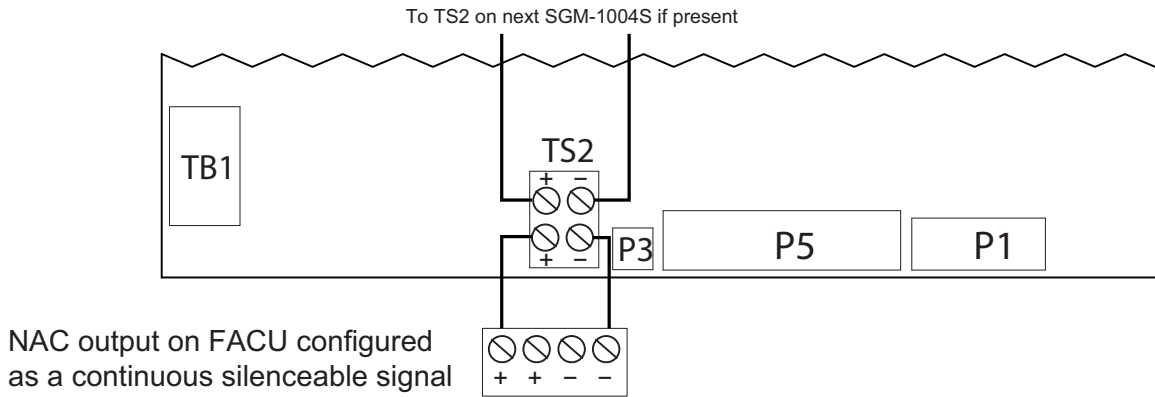

4.13 RM-1008A Hardwire Relay Adder Module

Figure 26 Hardwire Relay Adder Module RM-1008A

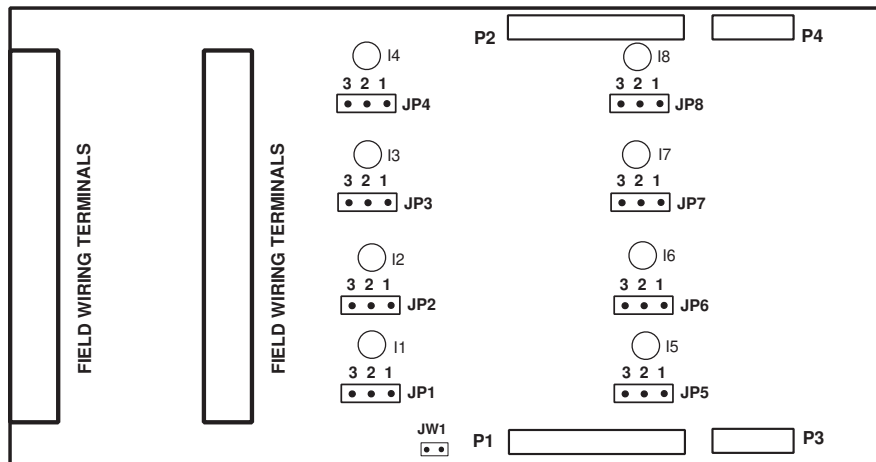

P2: Data cable to P6 or P5 of main fire alarm module, or to previous adder module.

P1: Data connector for next adder module.

P4: Power connector to P8 of main fire alarm module, or to previous adder module.

P3: Power connector for next adder module.

JW1: Remove continuity jumper if there are any more adder modules installed. If this is the last module installed, leave JW1 on.

JP1-JP8: Move jumpers from pins 1 and 2 to 2 and 3 to connect relay commons between two or more relays.

4.14 Polarity Reversal and City Tie Module PR-300

Figure 27 Polarity Reversal and City Tie Module

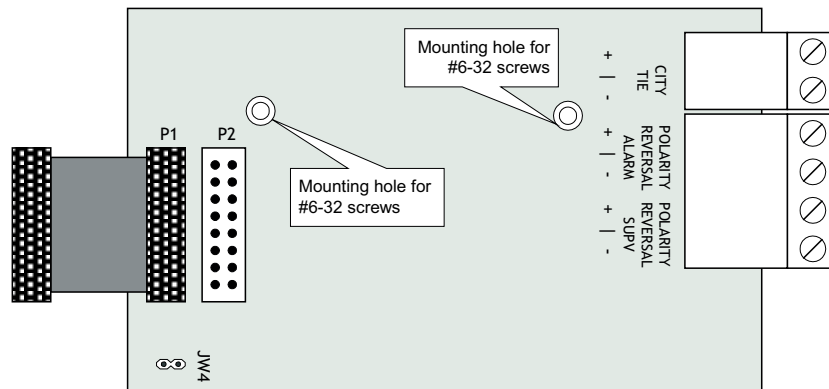

The following hardware configuration must be performed before installing the PR-300.

Table 11: PR-300 jumper settings

P1	Cable connects to P4 on the FleX-Net™ FX-4000 Main Fire Alarm Board
P2	Not used. If a UDACT-300A is used in conjunction with a PR-300, then the UDACT-300A ribbon cable P1 is connected to header P2 of the PR-300.
JW4	Jumper JW4 is always left intact.

The Alarm Transmit signal to the PR-300 can be programmed to turn OFF when signal silence is active (Not allowed by UL 864, refer to Configuration section of this manual). This allows the City Tie Box to be manually reset. On subsequent alarms the silenceable signals will resound and the City Tie Box will be retriggered. Please refer to the Configurator for more information.

The Trouble Transmit signal to the PR-300 can be programmed to delay AC power fail. Please refer to the Configurator for more information.



Note: Jumper JW1 on the FleX-Net™ FX-4000 main fire alarm board must be removed if a city tie module is installed.

4.15 UDACT-300A Main Board

There are two jumpers on the UDACT-300A which are used for operation/configuration purposes. Jumper JW1 is used to reset the default passcode. Jumper JW2 is required for configuring (which can be done using the FleX-Net™ FX-4000 Configurator Software) the UDACT-300A. Refer to Figure 28 below for location of jumpers, cable connections, pushbutton and LEDs. Table 12 following, provides a description of the user items on the UDACT-300A.

Figure 28 UDACT-300A Board Layout

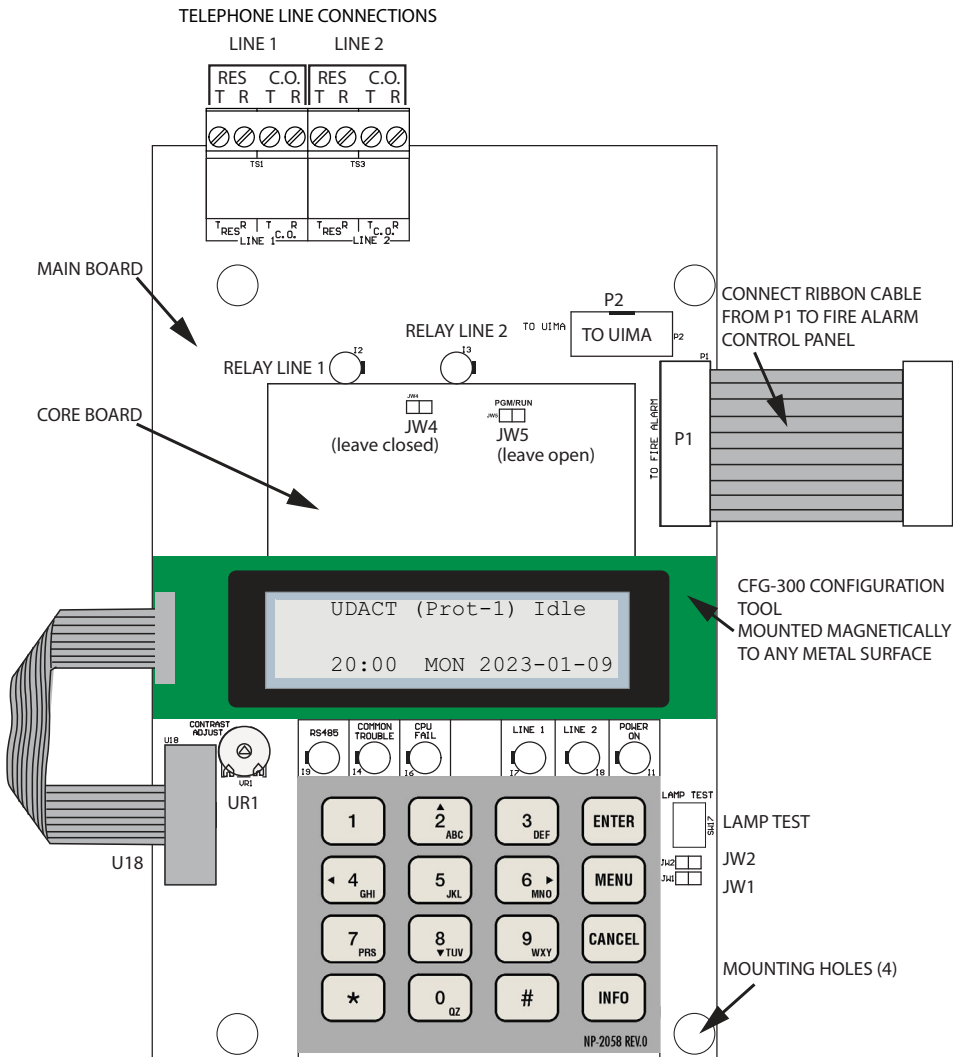

Table 12: UDACT-300A Connectors

Cable Connector	Function
P1	Ribbon Cable for connecting to P4 of FleX-Net™ FX-4000 main fire alarm board or to P2 header on the PR-300 if used.
P2	RS-232C/RS-485 Connection for computer configuration.
U18	Connector for CFG-300 Configuration Tool
Lamp Test button	Press and hold this button to test all the UDACT-300A LEDs
UR1 Potentiometer	This potentiometer is for adjustment of the CFG-300 LCD contrast.

The following table lists all the LEDs located on the UDACT-300A board and states the function of each LED.

Table 13: UDACT-300A LEDs

LEDs	LED Function
Relay Line 1	Located below Line 1 terminal block. When Line 1 relay is energized, this green LED will illuminate
Relay Line 2	Located below Line 2 terminal block. When Line 2 relay is energized, this green LED will illuminate.
RS-485	Status LED for communication, will flash when RS-485 communication is active.
Common Trouble	Steady amber for any troubles on the Fire Alarm panel or UDACT-300A.
CPU Fail	Steady amber for any on board CPU trouble.
Telephone Line 1	Telephone status indicator LED; Red when the line is in use, Amber when there is a line trouble.
Telephone Line 2	Telephone status indicator LED; Red when the line is in use, Amber when there is a line trouble.
Power ON	Green LED is ON steady when power is supplied to the board.

The following table lists the user jumpers available on the UDACT-300A and their functions.

Table 14: UDACT-300A Jumpers

Jumper Number	Jumper Function
JW1	Normally open. Place jumper here and power down the UDACT-300A by disconnecting P1 or power down the fire alarm panel (AC and Batteries), then power back to revert to default passcode. After reset, remove the jumper. Leave normally open.
JW2	Normally open to BLOCK remote configuration via modem, PC with a UIMA converter module or using the LCD and keypad at the UDACT-300A. Place jumper here to ALLOW any type of configuration. Remove jumper once configuration is complete.



Note: This module cannot be installed if a city tie module is used.

Jumper JW1 on the Flex-Net™ FX-4000 main fire alarm board must be removed if a UDACT-300A is installed.

See the *UDACT-300A Installation and Operation Manual LT-888* for more information.

4.16 ALCN-960MISO Isolated Quad Loop Adder Module with ALCN-960D Daughter Board

The ALCN-960MISO Quad Loop Adder Isolated module provides two addressable loops plus an additional two loops as part of the daughter board ALCN-960D which is mounted over the ALCN-960MISO. The Quad Loop Adder module may be mounted over the main chassis of the Network Fire Alarm Panel or on any chassis that supports adder boards. This module is mounted using four #6 screws and (if necessary) four 1 1/2" spacers.

Power	The power is supplied to the board via cable from the main chassis board or from the previous loop controller module into the P1 POWER IN connector. Connect the P2 POWER OUT connector to the next loop controller module or other adder module. One power cable is supplied with this module.
RS-485	The RS-485 cable comes attached at P4 on ALCN-960MISO and is either connected to P3 of the main fire alarm controller module or connected from the previous loop controller module or other adder board. If the next connected loop controller module is used, connect the RS-485 out at P3 on ALCN-960MISO to the next loop controller module; if it is not used, leave without connection.
DIP Switches	Use the DIP switches to set the binary address of the board. SW1-1 is the lowest significant digit and ON is active. For example, an address of two would be created by turning SW1-1 OFF, SW1-2 ON and DIP switches SW1-3 to SW1-8 OFF. Refer to Appendix C.
Loop 1	These are the terminals for SLC loop 1 addressable devices. Wire the loop as shown in section 5.2.
Loop 2	These are the terminals for SLC loop 2 addressable devices. Wire the loop as shown in section 5.2.
Shield	If the SLC loops are shielded, connect the shields to the terminals marked COM(-). To prevent the board reporting a ground fault, do not connect shields on SLC lines to earth ground. Note: Unshielded wiring is preferred.
Jumpers	JW1: Factory use only. Leave open. JW2: Factory use only. Leave closed.
JTAG Port	This connection is for factory use only.
USB Port	This connection is for factory use only.

The location of Loop 1 and 2 terminals, cable connectors, DIP switch location, and jumper locations on ALCN-960MISO are shown in Figure 29 below.

Figure 29 ALCN-960MISO Isolated Quad Loop Adder Module

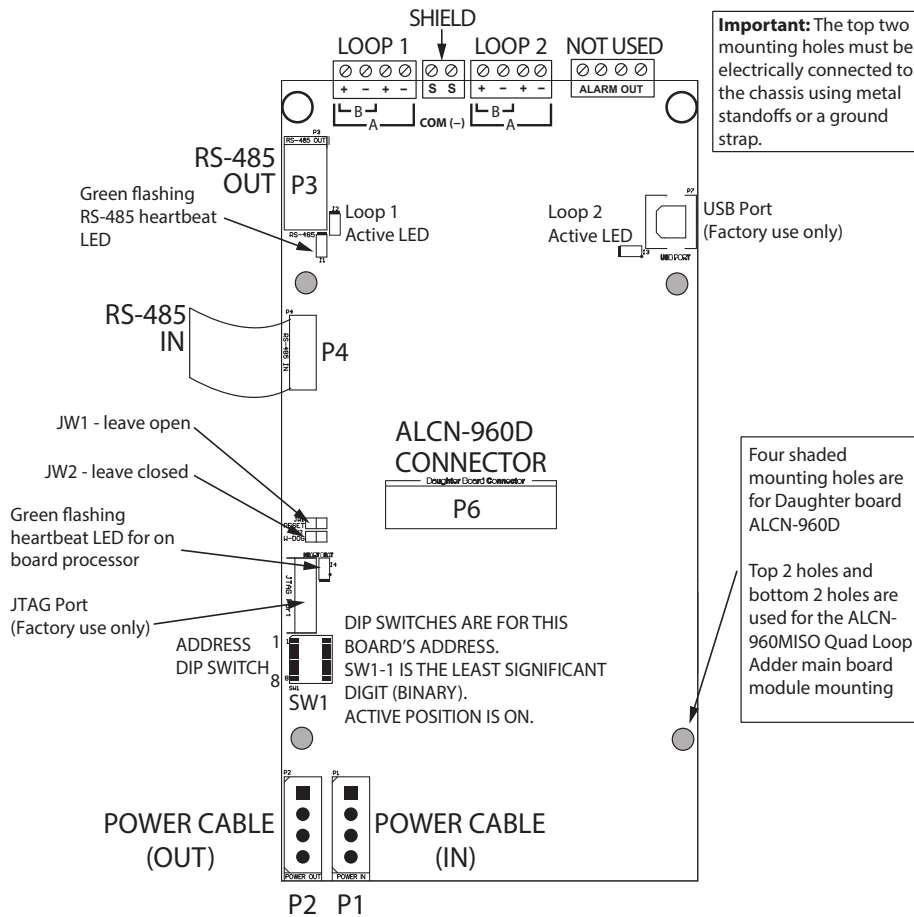

Notes for ALCN-960MISO and ALCN-960D:

- All circuits are power limited and must use type FPL, FPLR, or FPLP power limited cable.
- Loop wiring: maximum loop resistance is 40 Ω total. These lines are power-limited and fully supervised.

4.16.1 ALCN-960MISO DIP Switch Setting

Set the DIP switches on SW1 starting at address 1 for the first ALCN-960MISO adder and consecutively up to seven for the next six ALCN-960MISO modules. Refer to Appendix C for DIP switch settings.

4.16.2 ALCN-960D Daughter Board Installation

The location of Loop 3 and 4 terminals on ALCN-960D are shown in Figure 30 below.

The ALCN-960D Daughter Board provides another two addressable SLC loops when connected to the ALCN-960MISO Quad Loop Adder Board. This daughter board is mounted over the ALCN-960MISO using the four screws and spacers provided. Wire the two addressable loops on the ALCN-960D Daughter Board in the same manner as the ALCN-960MISO addressable loops are wired.

If the SLC loops have shielding, connect the shields to the terminals marked COM(-). To prevent the board reporting a ground fault, do not connect shields on SLC lines to earth ground.

Note: Unshielded wiring is preferred.

Figure 30 ALCN-960D Daughter Board

Four mounting holes (mount to ALCN-960MISO board with screws and spacers provided)

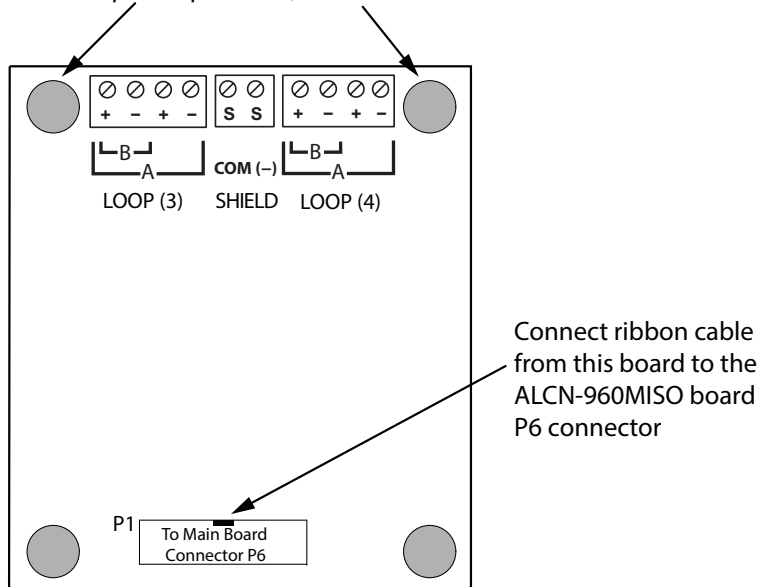

Notes for ALCN-960D:



- All circuits are power limited and must use type FPL, FPLR, or FPLP power limited cable.
- Loop wiring: maximum loop resistance is 40 Ω total. These lines are power-limited and fully supervised.

4.17 ALCN-4792MISO Isolated Quad Loop Adder Module with ALCN-792D Daughter Board

The ALCN-4792MISO Quad Loop Adder module provides two addressable loops plus an additional two loops as part of the daughter board ALCN-792D which is mounted over the ALCN-4792MISO. The Quad Loop Adder module may be mounted over the main chassis of the Network Fire Alarm Panel or on any chassis that supports adder boards. This module is mounted using four #6 screws and (if necessary) four 1 1/2" spacers.

Power	The power is supplied to the board via cable from the main chassis board or from the previous loop controller module into the P1 POWER IN connector. Connect the P2 POWER OUT connector to the next loop controller module or other adder module. One power cable is supplied with this module.
RS-485	The RS-485 cable comes attached at P4 and is either connected to P3 of the main fire alarm controller module or connected from the previous loop controller module or other adder board. If the next loop controller module is used, connect the RS-485 out at P3 on ALCN-4792MISO to the next loop controller module; if it is not used, leave without connection.
DIP Switches	Use the DIP switches to set the binary address of the board. SW1-1 is the lowest significant digit and ON is active. For example, an address of two would be created by turning SW1-1 OFF, SW1-2 ON and DIP switches SW1-3 to SW1-8 OFF. Refer to Appendix C.
Loop 1	This is the addressable loop for all initiating devices. Wire the loop as shown in section 5.2.
Loop 2	This is the addressable loop for all initiating devices. Wire the loop as shown in section 5.2.
Shield	If the loops are shielded, connect the shields to the terminals marked COM(-). To prevent the board reporting a ground fault, do not connect shields on SLC lines to earth ground. Note: Unshielded wiring is preferred.
Jumpers	ALCN-4792MISO: <ul style="list-style-type: none"> • JW1: Factory use only. Leave open. • JW2: Factory use only. Leave closed. • JW3: 3 pin jumper. Normally set to 1-2, can be set to 2-3 to prevent noise from CLIP System Sensor sounder bases on Loop 1. Pin 1 is marked with a dot. • JW4: 3 pin jumper. Normally set to 1-2, can be set to 2-3 to prevent noise from CLIP System Sensor sounder bases on Loop 2. Pin 1 is marked with a dot. • JW6: Factory use only. Leave closed. ALCN-792D: <ul style="list-style-type: none"> • See section 4.17.2.
JTAG Port	This connection is for factory use only.
USB Port	This connection is for factory use only.

The location of Loop 1 and 2 terminals on ALCN-4792MISO are shown in Figure 31 below. Also shown are the power in and out cable locations, DIP switch location, and jumper locations.

Figure 31 ALCN-4792MISO Quad Loop Adder Module

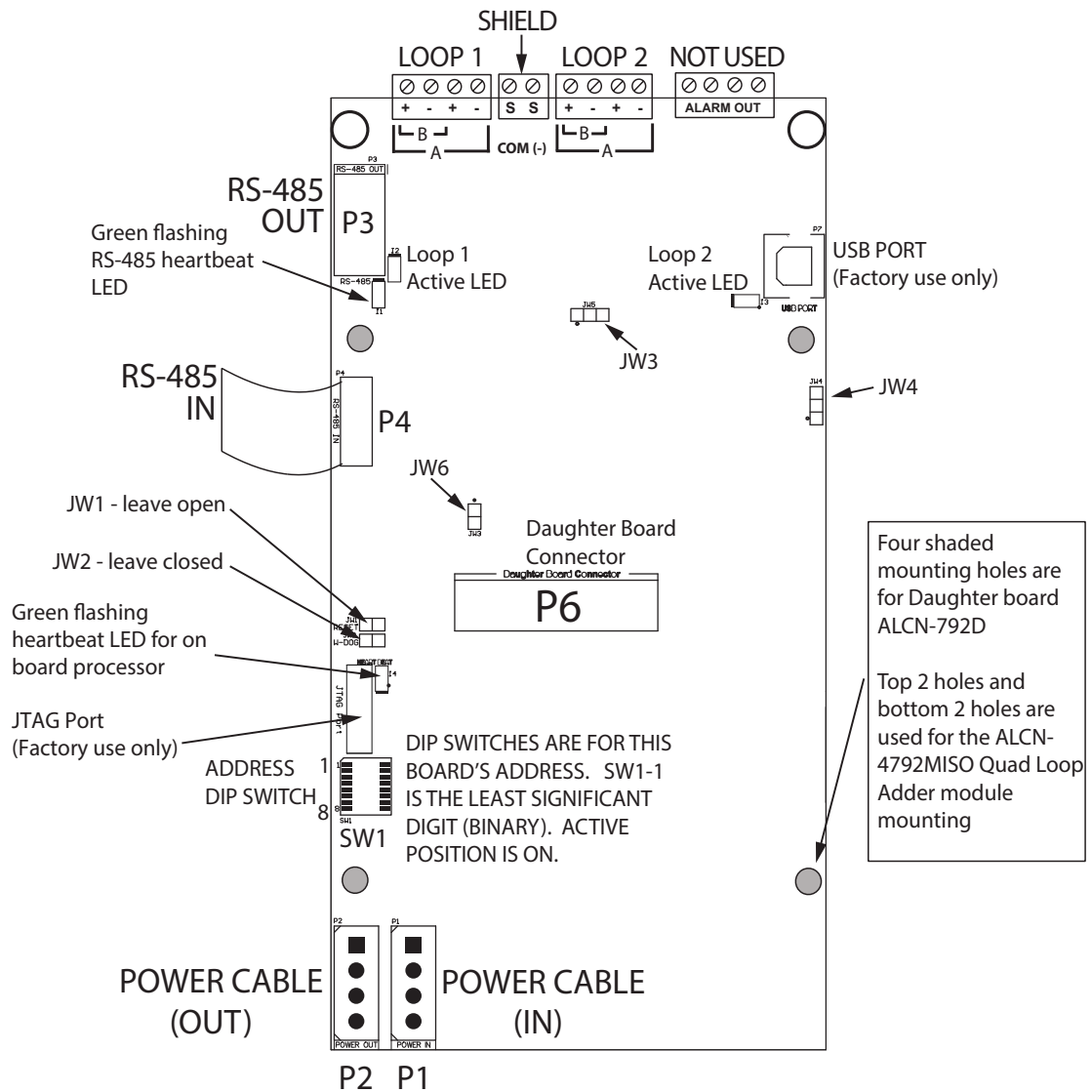

Wiring The Addressable Loops:

- There are two addressable loops present on this board that are wired in the same manner as shown in the wiring diagrams in section 5.2. Although these drawings show only Loop 1; Loop 2 is wired in the same way as Loop 1 is.

Notes for ALCN-4792MISO:

- All circuits are power limited and must use type FPL, FPLR, or FPLP power limited cable.
- Loop wiring: maximum loop resistance is 40 Ω total. These lines power-limited and fully supervised.

4.17.1 ALCN-4792MISO DIP Switch Setting

Set the DIP switches on SW1 starting at address 1 for the first ALCN-4792MISO adder and consecutively up to seven for the next six ALCN-4792MISO modules. Refer to Appendix C for DIP switch settings.

4.17.2 ALCN-792D Daughter Board Installation

The location of Loop 1 and 2 terminals on ALCN-792D are shown in Figure 32 below. Also shown are the jumper locations.

The ALCN-792D Daughter Board provides another two addressable loops when connected to the ALCN-4792MISO Quad Loop Adder Board. This daughter board is mounted over the ALCN-4792MISO using the four screws and spacers provided. Wire the two addressable loops on the ALCN-792D Daughter Board in the same manner as the ALCN-4792MISO addressable loops are wired.

If the loops have shielding, connect the shields to the terminals marked COM(-). To prevent the board reporting a ground fault, do not connect shields on SLC lines to earth ground.

Note: Unshielded wiring is preferred.

Figure 32 ALCN-792D Daughter Board

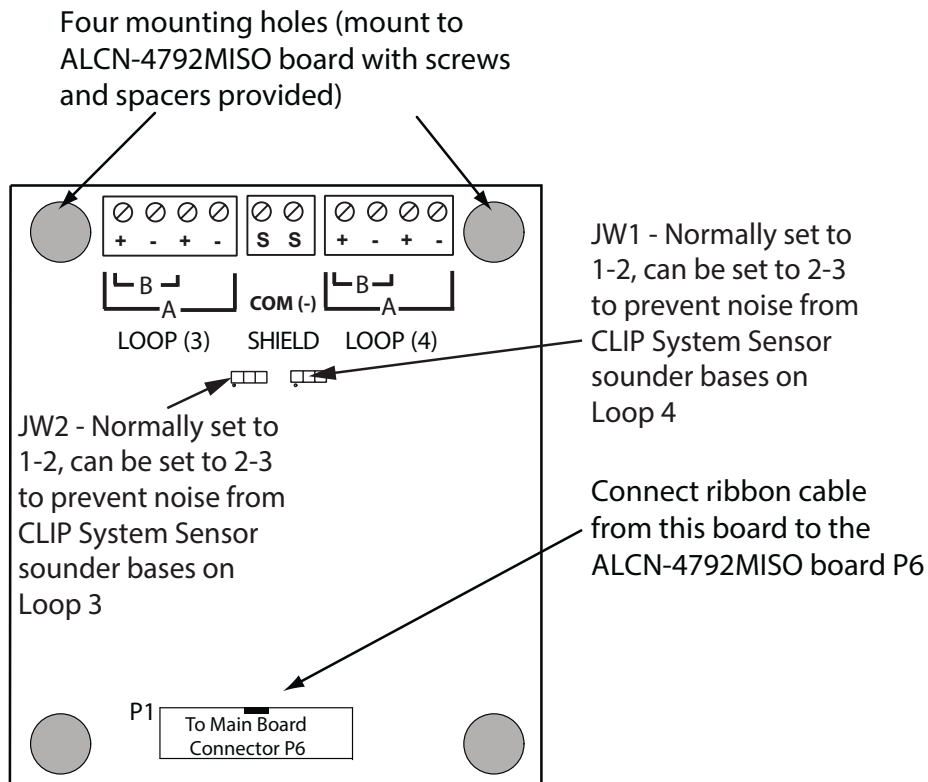

Notes for ALCN-792D:

- Unshielded wiring is preferred.
- All circuits are power limited and must use type FPL, FPLR, or FPLP power limited cable.
- Loop wiring: maximum loop resistance is 40 Ω total. These lines are power-limited and fully supervised.



5.0 Field Wiring for Fire Alarm

5.1 Main Fire Alarm Board Wiring

Wire devices to terminals as shown in Figure 33 below. Refer to Appendix A for specifications and to LT-1023 for compatible devices.



Attention: Do not exceed power supply ratings:
Main Chassis: FX-6000MNS-CH: total current for NACs is 10A max.



Notes: All wiring shall be in accordance with NFPA 70 and CSA C22.1, Safety Standard for Electrical Installations, Canadian Electrical Code.
The terminal blocks are removable for ease of wiring.
All power limited circuits must use type FPL, FPLR, or FPLP power limited cable.

Figure 33 Main Fire Alarm Controller Board Field Terminal Connections

MD-871A Main Fire Alarm Controller board

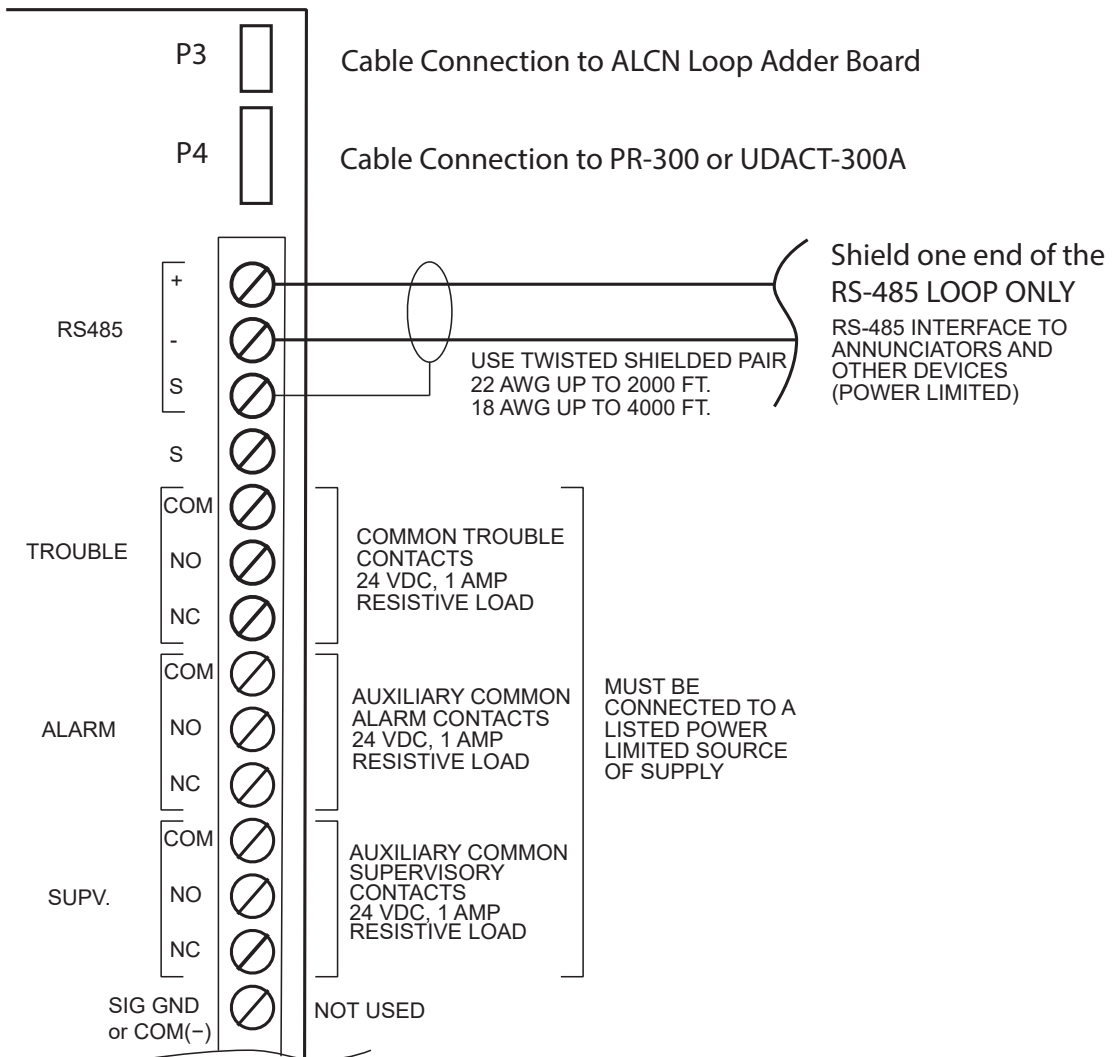
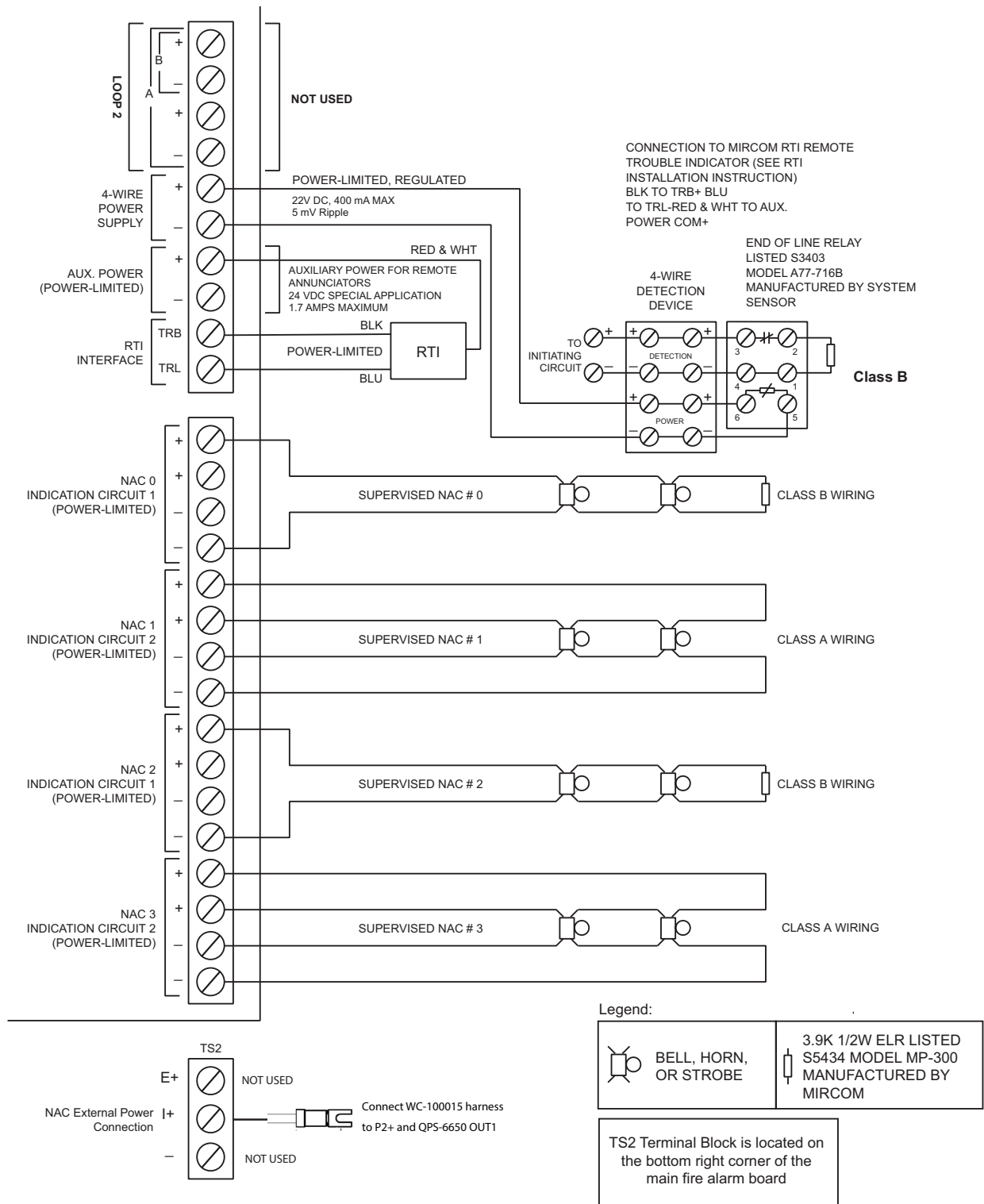

Figure 34 Main Fire Alarm Control board Field Terminal Connections (continued)



Note: All circuits are power limited (unless marked otherwise) and must use type FPL, FPLR, or FPLP power limited cable.

NACs are fully supervised and rated for regulated 24 VDC, 1.7A max. They must be wired as shown in section 5.10.



5.2 Addressable Loop Wiring

Figure 35 Quad Loop Terminal Connections - Class B

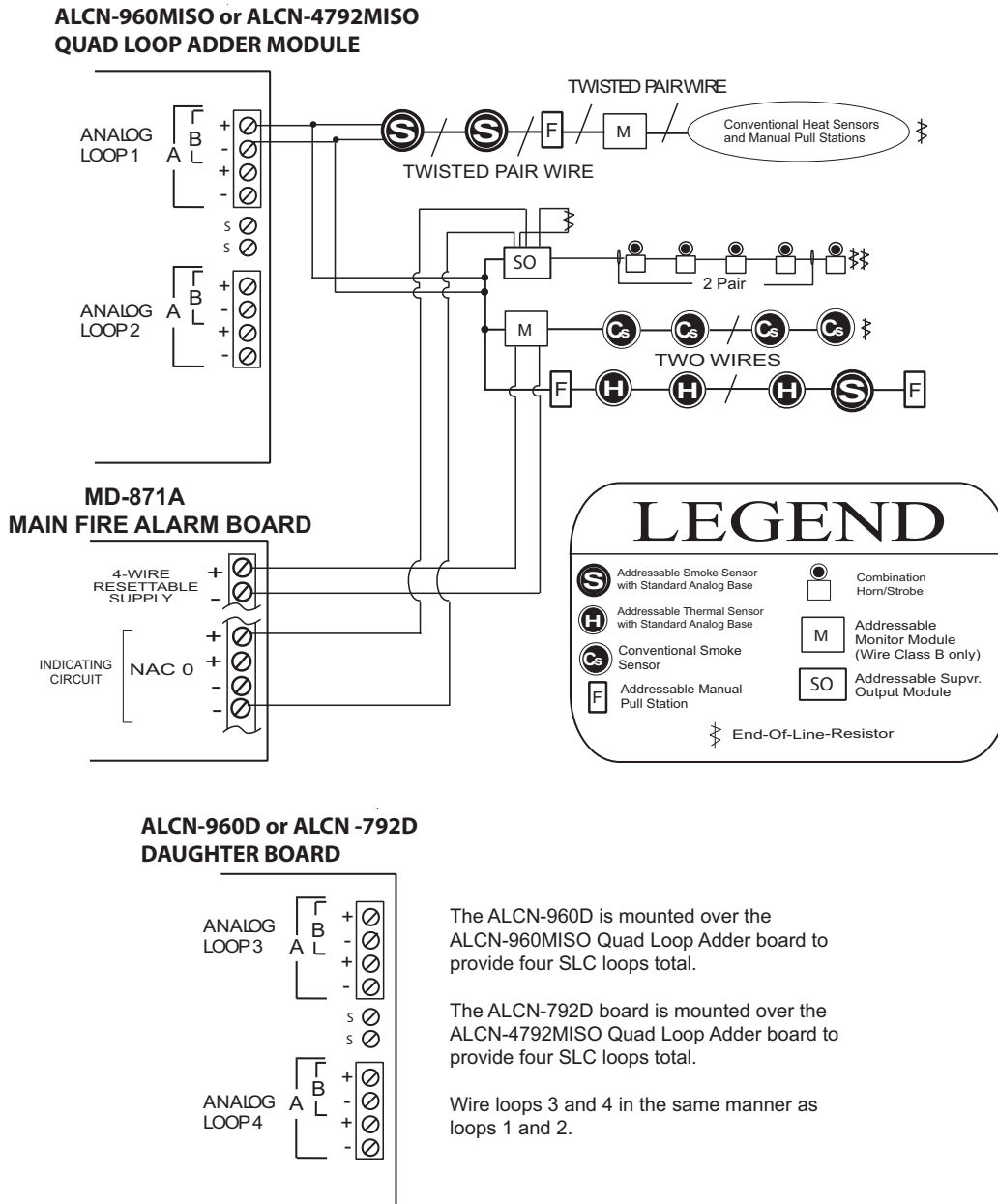

i

Note: All power limited circuits must use type FPL, FPLR, or FPLP power limited cable.
Loop wiring: maximum loop resistance is 40 Ω total. These lines are power-limited and fully supervised.

Figure 36 Quad Loop Adder Module Terminal Connections - Class X (Formerly Style 7)

**ALCN-960 MISO or ALCN-4792MISO
QUAD LOOP ADDER MODULE**

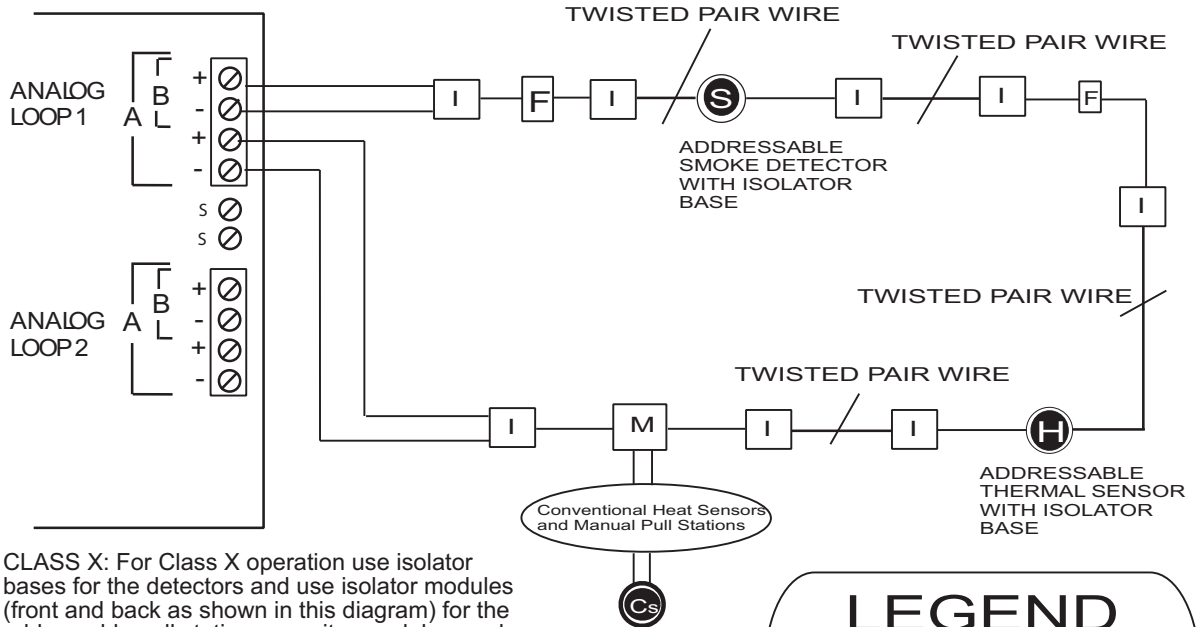

CLASS X: For Class X operation use isolator bases for the detectors and use isolator modules (front and back as shown in this diagram) for the addressable pull stations, monitor modules, and control modules

TWISTED SHIELDED PAIR WIRE IS NOT RECOMMENDED. IF USED THE SHIELD SHOULD BE TERMINATED AT THE TERMINALS MARKED SHIELD

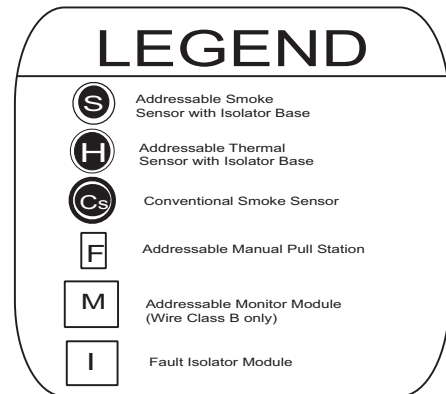

**ALCN-960D or ALCN-792D
DAUGHTER BOARD**

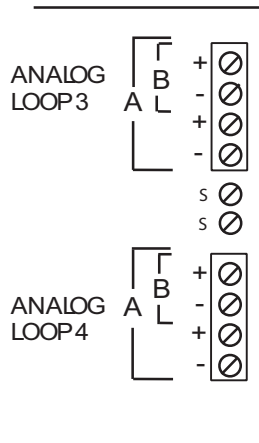

The ALCN-960D is mounted over the ALCN-960MISO Quad Loop Adder board to provide four SLC loops total.

The ALCN-792D board is mounted over the ALCN-4792MISO Quad Loop Adder board to provide four SLC loops total.

Wire loops 3 and 4 in the same manner as loops 1 and 2.



Note: All power limited circuits must use type FPL, FPLR, or FPLP power limited cable. Isolators need to be close nipple connected to the device being protected. Loop wiring: maximum loop resistance is 40 Ω total. These lines are power-limited and fully supervised.

Figure 37 Quad Loop Adder Module Terminal Connections - Class A

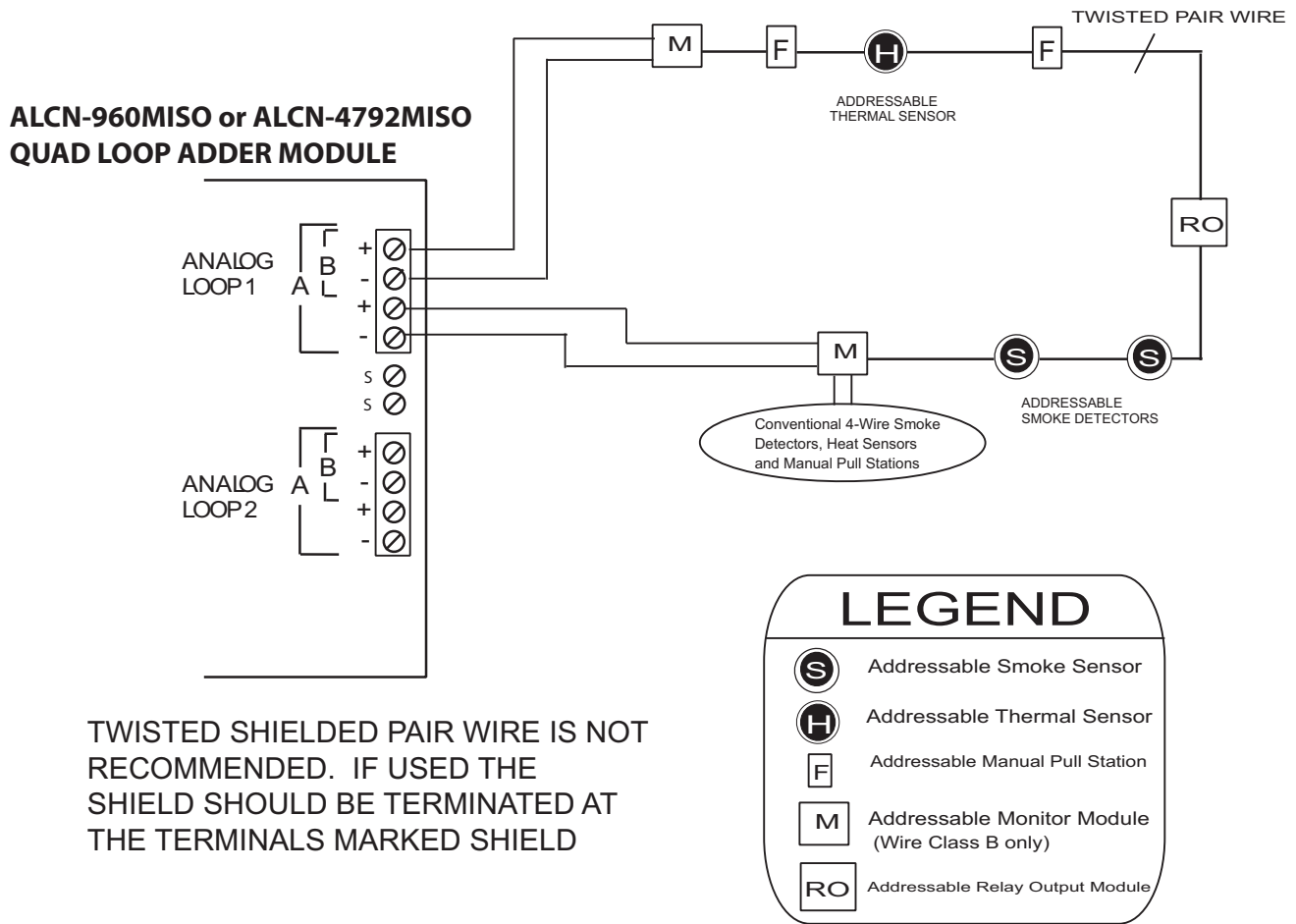

ALN-960D or 792D DAUGHTER BOARD

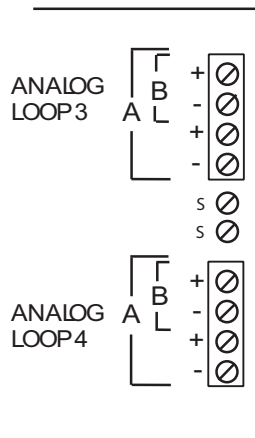

The ALN-960D is mounted over the ALN-960MISO Quad Loop Adder board to provide four SLC loops total.

The ALN-792D board is mounted over the ALN-4792MISO Quad Loop Adder board to provide four SLC loops total.

Wire loops 3 and 4 in the same manner as loops 1 and 2.



Note: All power limited circuits must use type FPL, FPLR, or FPLP power limited cable. Loop wiring: maximum loop resistance is 40 Ω total. These lines are power-limited and fully supervised.

5.3 Network Wiring

5.3.1 FNC-2000 Fire Network Controller Module Wiring

The FNC-2000 Fire Network Controller modules are wired from terminals marked Line A, positive and negative (see specific cable recommended in Figure 38) to the Line B terminals of the next FNC-2000 module. **Use of shielded cable is not recommended.** Wire from Line B terminals to Line A of the next FNC-2000 module. Start from the lobby panel and wire to all the FNC-2000, wiring the last FNC-2000 back to Line B of the first FNC-2000 at the lobby panel for Class X.

Figure 38 Class X Wiring for the FNC-2000 Module

CLASS X WIRING

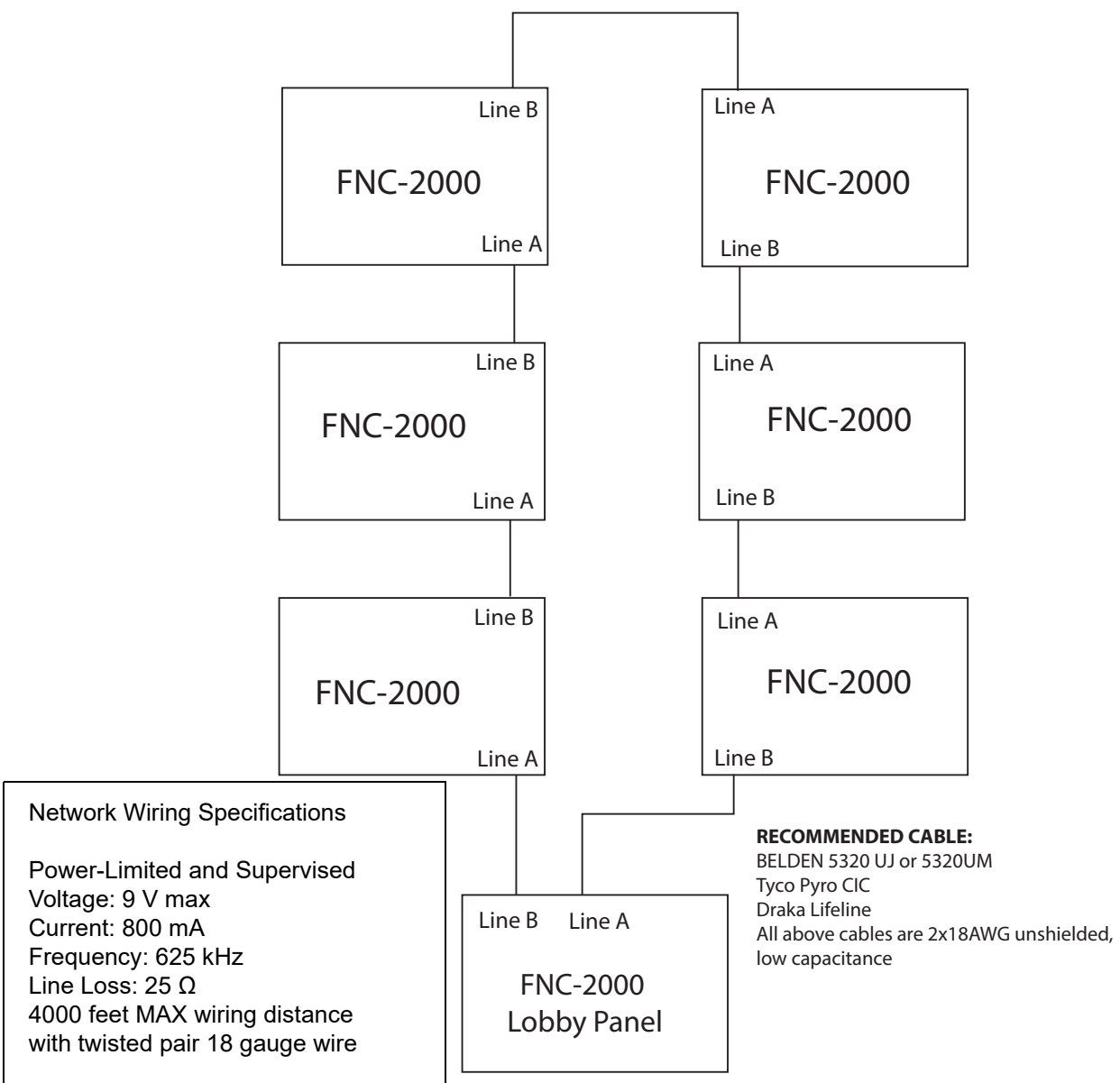

5.3.2 FOM-2000-UM Fiber Optic Network Adder Module

The FOM-2000-UM Fiber Optic Network Adder Module is wired with fiber optic cable. Connect L1 to L2 and L2 to L1 as shown in the Class A wiring of Figure 39. Refer to LT-6907 document for more wiring and installation information.

Figure 39 FOM-2000-UM Fiber Optic Network Adder Module Wiring

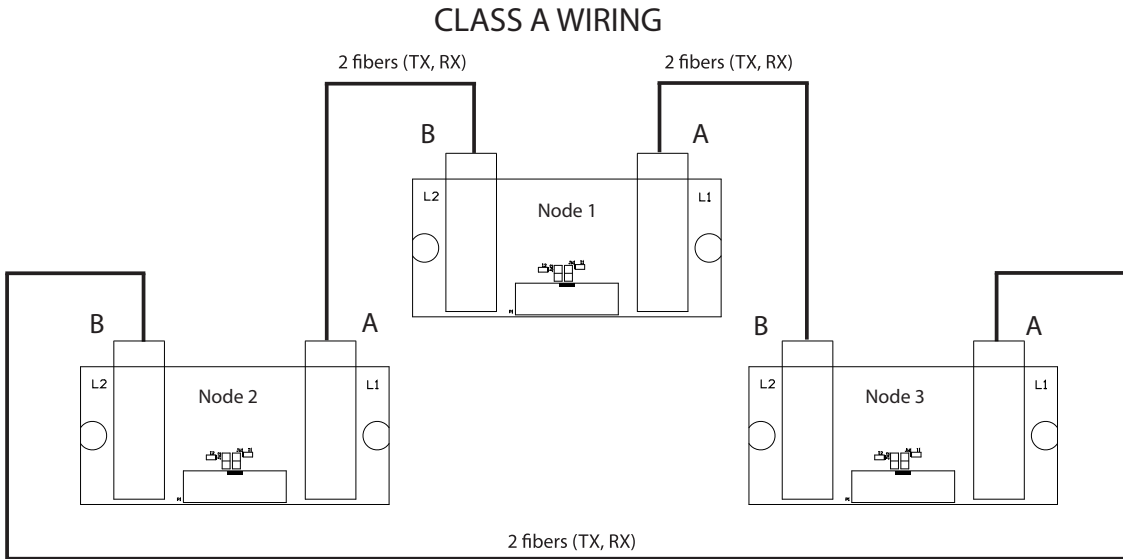

5.4 Analog Initiating Wiring

5.4.1 Detection Module DM-1008A Terminal Connections

Wire devices to terminals as shown below. See wiring tables, and Appendix A for electrical specifications and document LT-1023 for compatible devices.

Figure 40 Hardwire Detection Module DM-1008A Terminal Connections

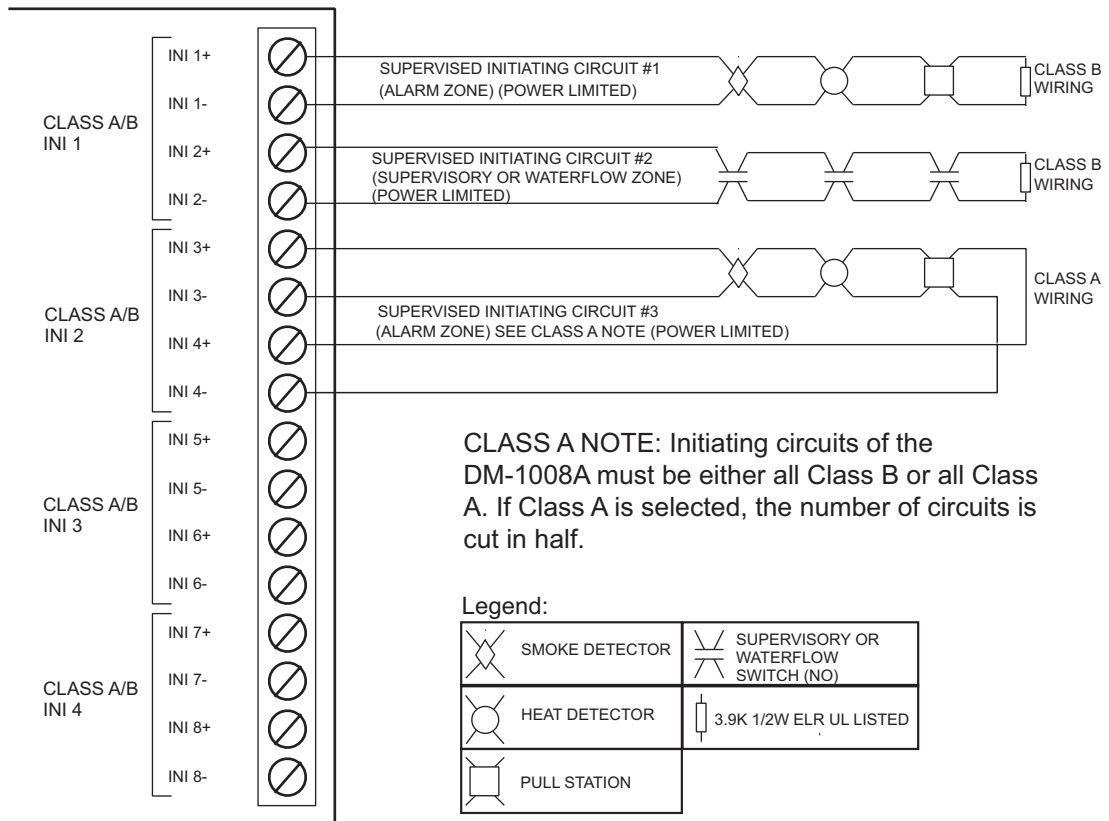

Note: Terminal blocks are “depluggable” for ease of wiring. All power limited circuits must use type FPL, FPLR, or FPLP power limited cable. Initiating circuits are fully supervised and rated for 22 VDC, 3 mA standby, 5 mV ripple, 50 mA max alarm. They may be configured as required. The alarm threshold is 21 mA. Maximum loop resistance is 100 Ω, 50 Ω per side. All conventional hardwire initiating circuits are Compatibility ID "A".



5.5 Analog NAC Wiring

5.5.1 Signal Module SGM-1004A Terminal Connections

Wire devices to terminals as shown in Figure 41 below. See Appendix A for signal module specifications, and LT-1023 for compatible devices.

Figure 41 Hardwire Signal Module SGM-1004A Terminal Connections

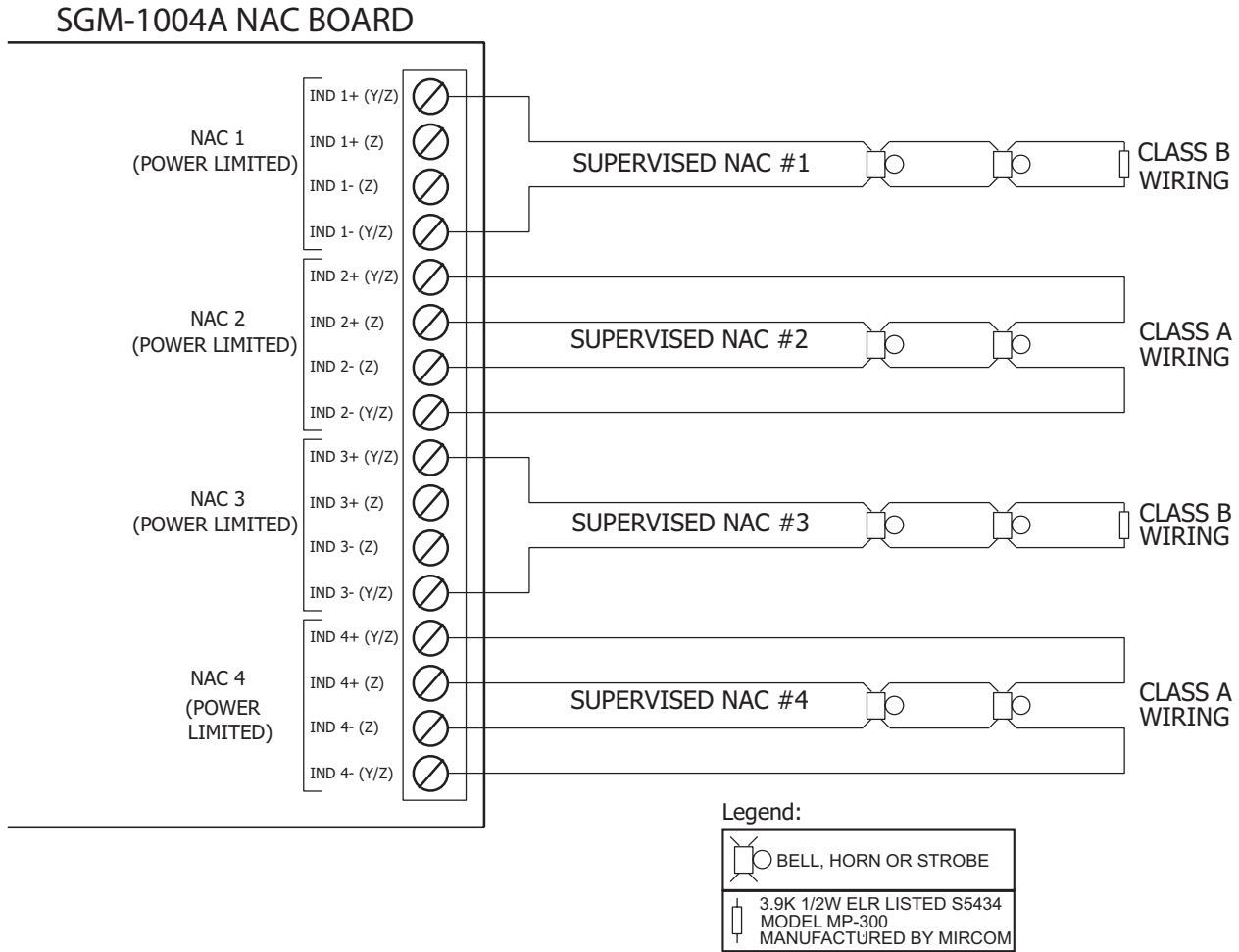

i

Note: The terminal blocks are depluggable for ease of wiring. All power limited circuits must use type FPL, FPLR, or FPLP power limited cable. SGM-1004A NACs are fully supervised and rated for 24 VDC regulated, 1.5A max. See section 5.10 for wire gauges and lengths.

5.5.2 Signal Module SGM-1004S Terminal Connections

Wire devices to terminals as shown in Figure 42 below. See Appendix A for signal module specifications, and LT-1023 for compatible devices.

Figure 42 Hardwire Signal Module SGM-1004S Terminal Connections

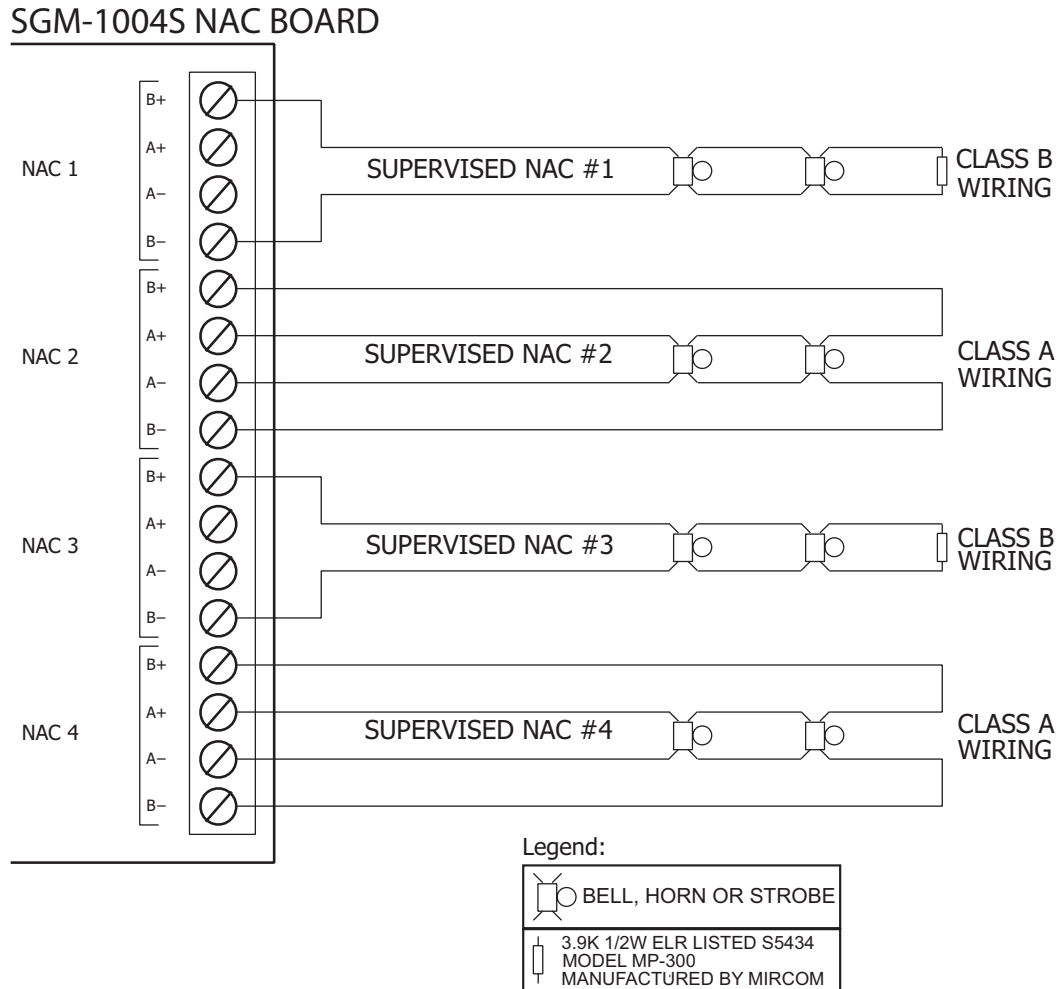

i

Note: The terminal blocks are depluggable for ease of wiring. The SGM-1004S NACs are either all power limited or all non-power limited. See section 4.12.5. All power limited circuits must use type FPL, FPLR, or FPLP power limited cable. See Appendix A for the ratings. See section 5.10 for wire gauges and lengths.

5.6 Analog Relay Wiring

5.6.1 Relay Module RM-1008A Terminal Connections

Relays are available as shown below.

Figure 43 Hardwire Relay Module RM-1008A Terminal Connections

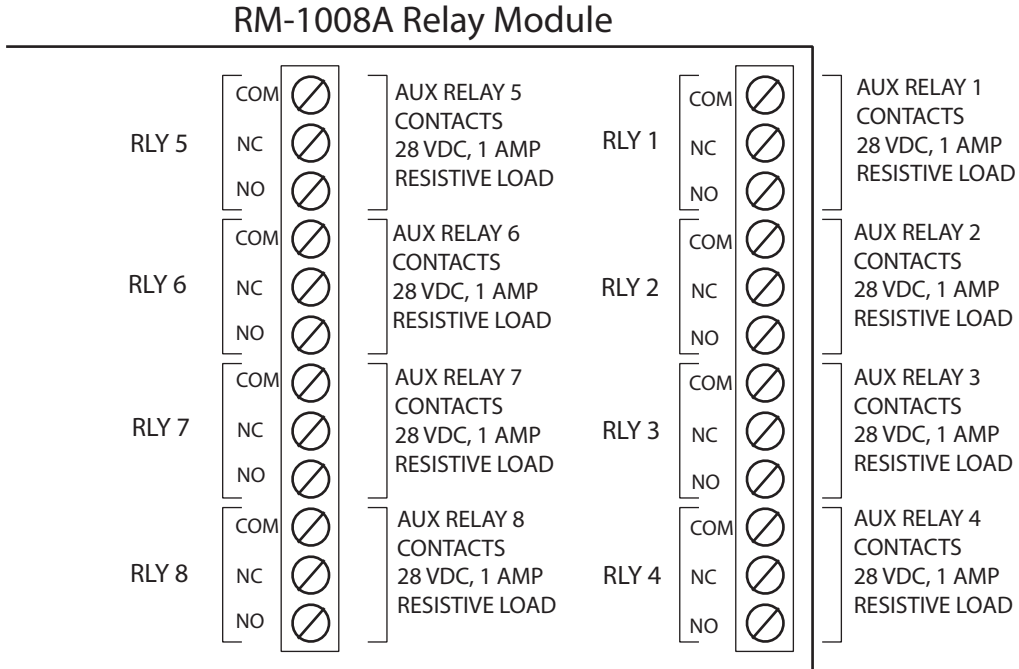

Note: All relay circuits are power limited and must use type FPL, FPLR, or FPLP power limited cable. All relay circuits must be connected to a listed power limited source of supply.



Attention: Do not connect any voltage greater than 30 VAC directly to these relays.

5.7 Polarity Reversal and City Tie Module PR-300 Wiring

Wire PR-300 Polarity Reversal and City Tie Module (if used) as shown in Figure 44 below. Power Limited cable type FPL, FPLR or FPLP must be used.

For USA installation, the installer must use **Atlantic Scientific (Tel: 407-725-8000), Model #24544 Protective Device**, or similar **UL-Listed QVRG secondary protector**, as shown.

For use in Canada, the Protective Device is not required but still recommended.

Figure 44 Polarity Reversal and City Tie Module PR-300 Terminal Connection

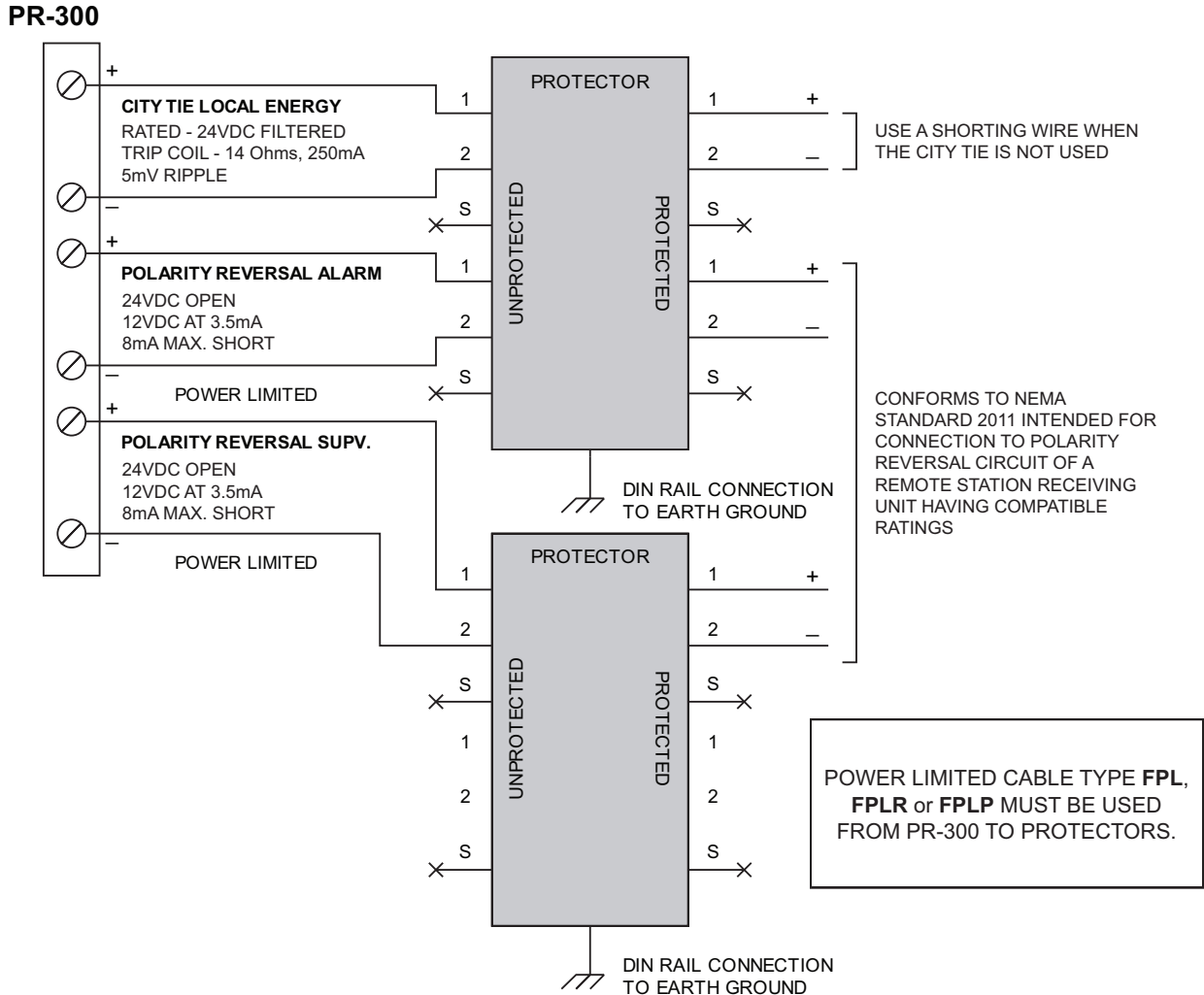

Note: Either the PR-300's city tie or polarity reversal interface may be used, but not both. The city tie interface is not power limited. Plug PR-300 ribbon cable P1 into connector P4 of the FleX-Net™ FX-4000 main fire alarm board. Cut jumper JW1 on the PR-300 module in order to transmit a trouble condition to the monitoring station. Remove jumper plug from jumper JW1 on the main fire alarm module. The polarity reversal interface is power limited and must use type FPL, FPLR, or FPLP power limited cable. For polarity reversal operation, short the city tie connection.

i

5.8 UDACT-300A Main Board Terminal Connections

Wire the two telephone lines to RJ31X Connector terminals as shown in Figure 45 below. The UDACT-300A terminals are located on the top left hand corner of the board.

i

Note: For two wired telephone lines see figure below. For combination wired and wireless, refer to UDACT-300A manual LT-888. To comply with UL 864 9th edition "Other Transmission Technologies" or UL 864 10th edition "Performance Based Technologies", wire as shown in figure below. Most Authorities Having Jurisdiction (AHJ) do not allow the connection of premise telephones, see specifications for more information.

Figure 45 Telephone Line Wiring Diagram

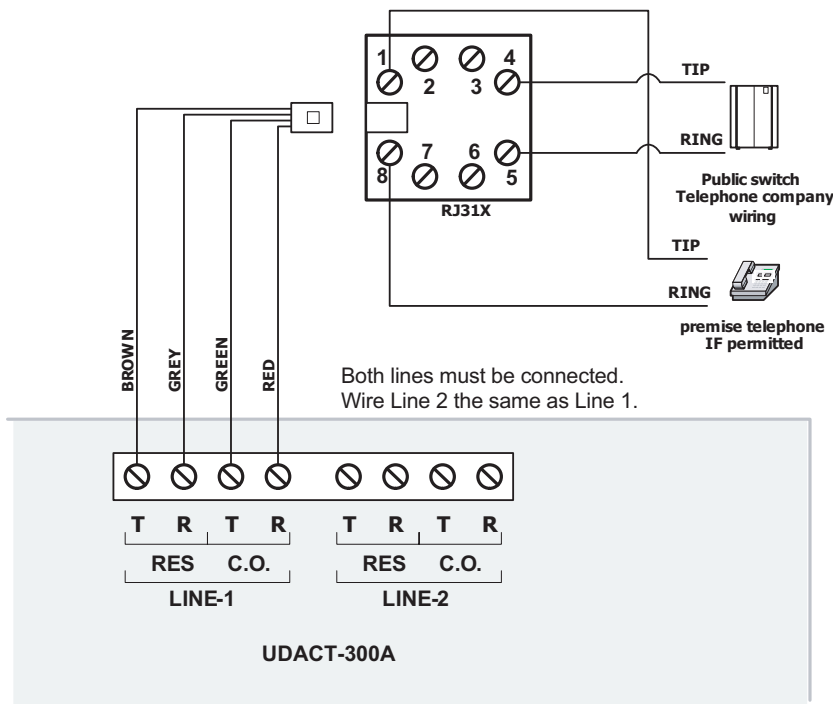

For wireless report, connect as below:

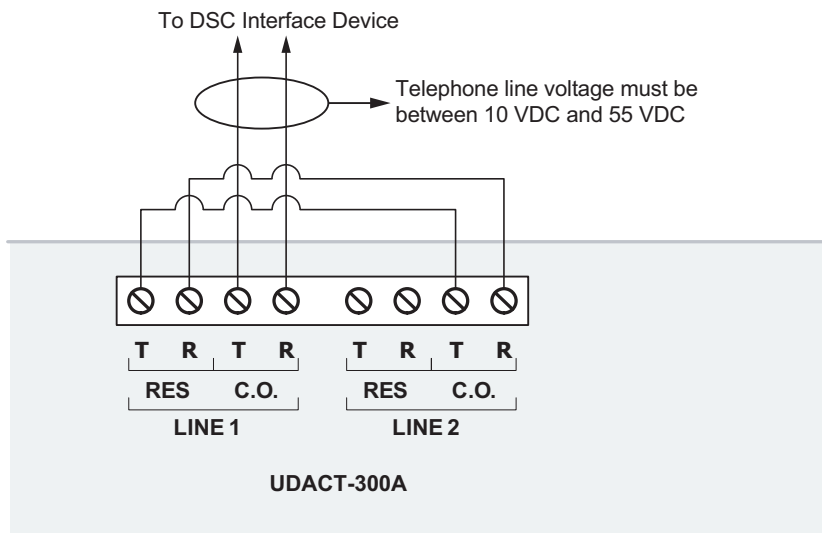
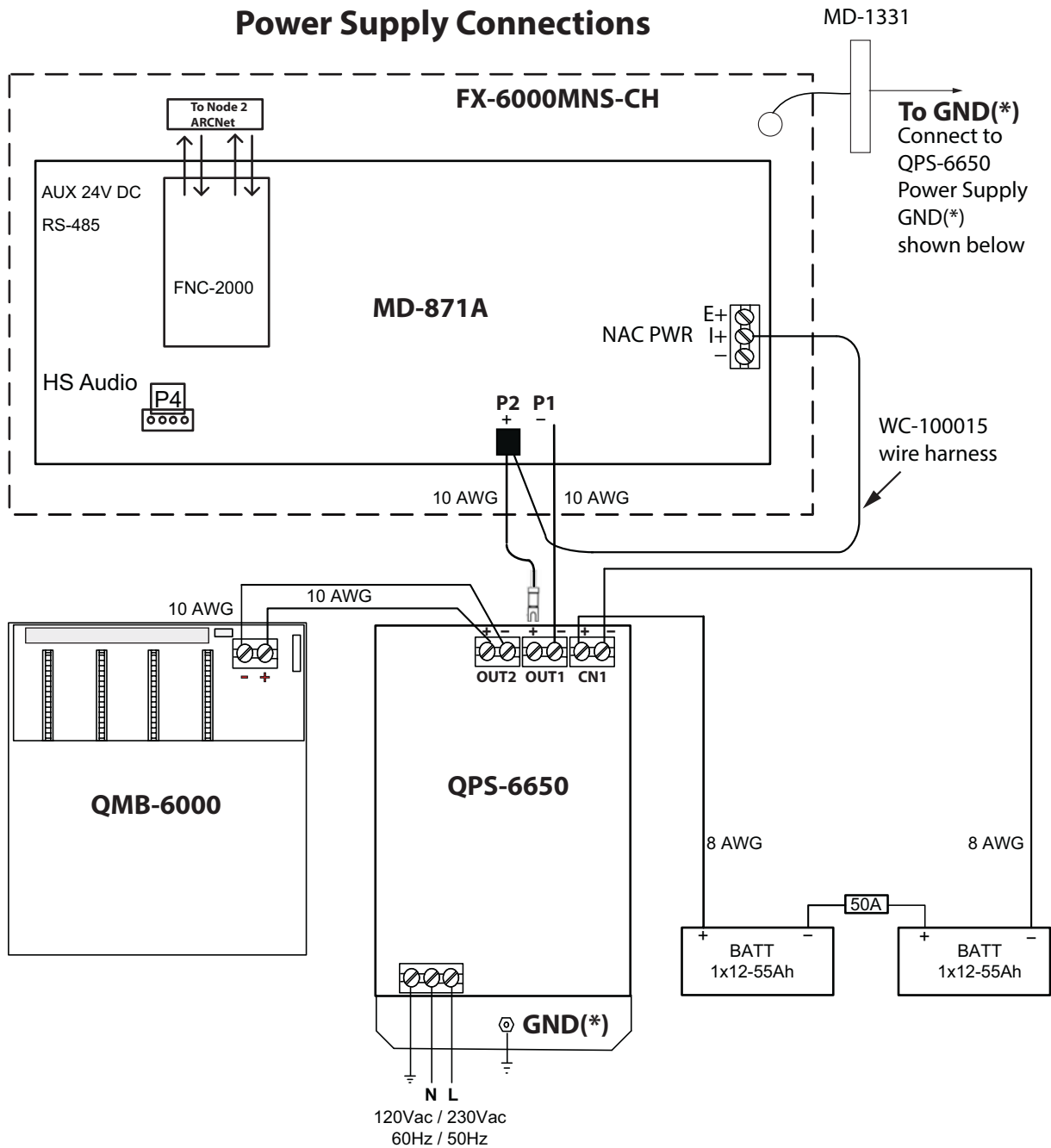

Figure 47 Power Supply Connections within BBX-FXMNS-6000 Enclosure.



Note: Remove the jumper on the NAC PWR terminal on the main board, and connect WC-100015 to the center I+ pin as shown in Figure 47.

5.10 Wiring Tables and Information

Table 16: Wiring for Initiating Circuits

Wire Gauge (AWG)	Maximum Wiring Run to Last Device (ELR)	
	ft.	m
22	2990	910
20	4760	1450
18	7560	2300
16	12000	3600
14	19000	5800
12	30400	9200

i

Note: Maximum loop resistance should not exceed 100 Ω .

Main board NACs are rated for 1.7 amps each. The SGM-1004A NACs are rated for 1.5 amps each. The SGM-1004S NACs are rated for 2.1 amps each.

Table 17: Wiring for NACs

Total Signal Load	Maximum Wiring Run to Last Device (ELR)								Max Loop Resistance
	Amperes		ft.		m		Ohms		
0.06	2350	716	3750	1143	6000	1829	8500	2591	30
0.12	1180	360	1850	567	3000	915	4250	1296	15
0.30	470	143	750	229	1200	366	1900	579	6
0.60	235	71	375	114	600	183	850	259	3
0.90	156	47	250	76	400	122	570	174	2
1.20	118	36	185	56	300	91	425	129	1.5
1.50	94	29	150	46	240	73	343	105	1.2
1.7	78	24	125	38	200	61	285	87	1.0

i

Note: Maximum voltage drop should not exceed 1.39 volts for main board and 1 volt for SGM-1004A and 3 volts for the SGM-1004S.

Table 18: Analog Loop Wiring

Wire Gauge (use twisted pair) (AWG)	Loop Total (Out and In) Maximum Twisted Pair Wire Run	
	ft.	m
12	10,000	3049
14	7971	2429
16	4980	1518
18	3132	955



Note: Line capacitance shall not exceed 0.5 μ F.
Inductance shall not exceed 1 mH.
Resistance shall not exceed 40 Ω .

Power Wiring: Use Table 17 to see the wiring information for the remote annunciator being used.

RS-485 Wiring: See the wiring information for the remote annunciator being used.

4-Wire Smoke Wiring: The maximum allowable current is 0.2 amperes. The maximum allowed voltage drop is 1 volt. Refer to Table 16.

Shield for Analog Loop Wiring: Only twisted pair is recommended, but if shielded twisted pair is used, wire shield at the start and the end of the loop to the terminals marked Shield at the loop adder board.

6.0 Field Wiring for Audio

The modules that mount into the audio card cage are the amplifier modules. Up to four amplifiers may be installed in each BBX-FXMNS-6000 enclosure and QBB-6001 Expansion Audio Cabinet. One of the four amplifiers may be designated as a backup amplifier through configuration. The backup amplifier can back up all the following connected amplifiers by physical wiring from the amplifier backplate to the next amplifier backplate.

6.1 QBB-6001 Enclosure (Expansion Cabinet) Assembly

The modules that mount into the QBB-6001 expansion audio cabinet include the QPS-6650 Power Supply, and up to two QMB-6000 Card cages. Module interconnects are shown in Figure 48.

Up to eight Amplifier Modules QAD-6425-25/QAD-6425-70 may be installed into two QMB-6000 card cages. The total maximum wattage per expansion audio cabinet is 575 watts.

Figure 48 QBB-6001 Expansion Audio Cabinet Module Placement

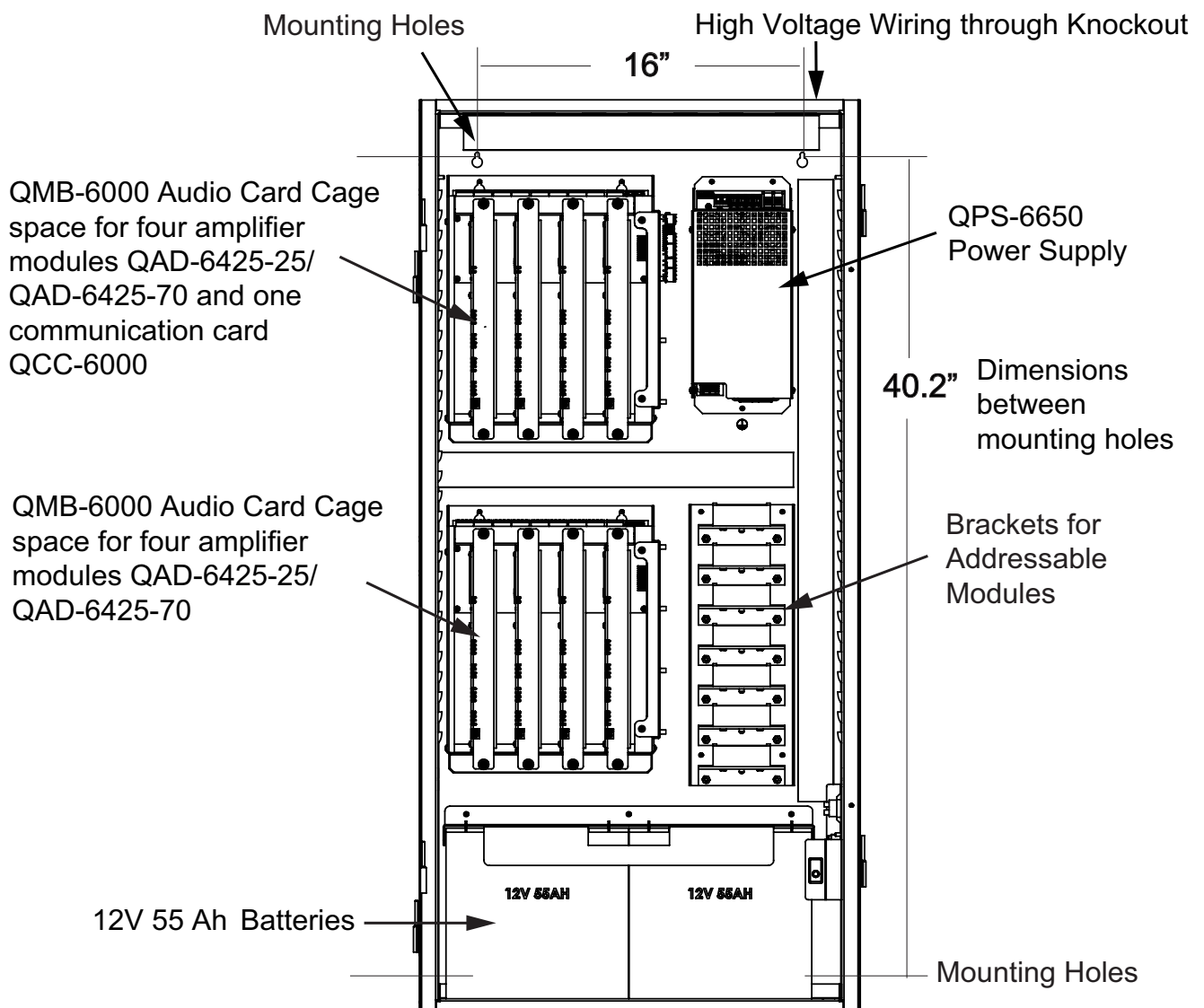

Components on the amplifiers should be facing right when inserted into backplane. Make sure connections for the power supply and battery charger are as shown above. Place all amplifier modules from left to right in slot positions one to four in each card cage. Up to 9 expansion audio cabinets QBB-6001 can be used per Fire Alarm Node.

6.2 Installing and Removing Amplifiers



Attention: Improper installation or excessive force will damage the backplane and amplifiers being installed or removed.

Figure 49 Installing an Amplifier

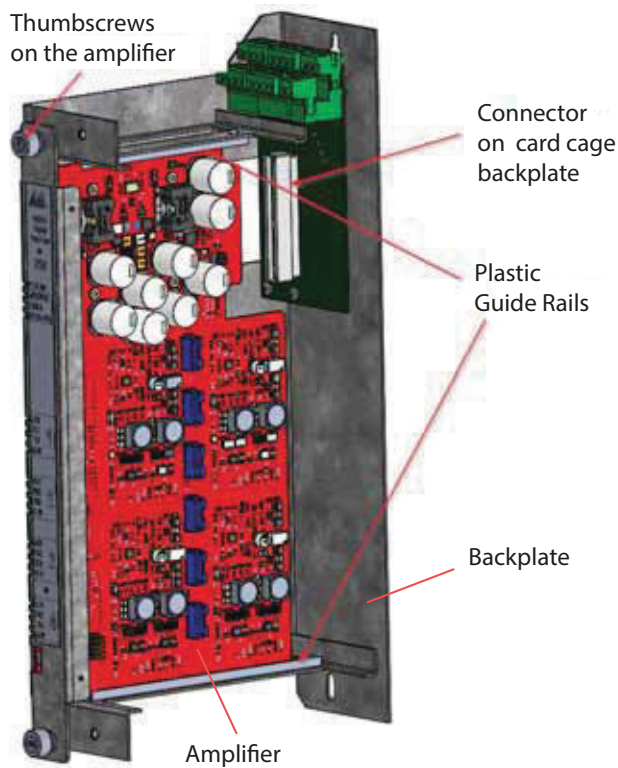

6.2.1 Installing QAD-6425-25/QAD-6425-70 Amplifier Modules

1. Hold the amplifier to be installed by the front metal face. *Do not* handle, push or pull any of the components on the amplifier this will damage those components.
2. Line up the amplifier being installed with the runners or guides on the card cage and slide the amplifier back to the point where the amplifier just about touches the pins on the backplane.
3. Make sure that the amplifier is square with the backplane.
4. Press the amplifier firmly from the front face toward the backplane until the amplifier is in position with the connector on the backplane and the amplifier snaps into place
5. Screw down the amplifier with the top and bottom screws provided on the amplifier card.

6.2.2 Removing the QAD-6425-25/QAD-6425-70 Amplifier Modules

1. Unscrew the two screws holding the amplifier in place. *Do not* handle, push or pull any of the components on the amplifier as this will damage those components.
2. Place the forefinger of one hand on the top section of the amplifier metal front plate and the forefinger of the other hand on the bottom edge of the amplifier metal front plate.
3. Carefully pull the amplifier forward until the amplifier connector is disconnected from the backplane connector.
4. Holding the amplifier firmly by the front metal, slide the amplifier forward and completely remove it from the card cage.



Attention: Power should be disconnected before removing and inserting modules and cables.

6.3 QCC-6000 Communication Card

The QCC-6000 communication card allows for remote audio cabinet expansion up to 2000 feet (suitable wire gauge is 18 AWG). It supports up to 9 expansion cabinets on each Flex-Net™ FX-4000 node.

1 QCC-6000 is required in every audio enclosure, even if there is no expansion cabinet.

Mount the QCC-6000 on the far right side of the audio card cage.

Use the rotary switch SW1 to set the card's address. The card in the main cabinet should be 0. Set each card consecutively so that there are no gaps.

Figure 50 QCC-6000 Communications Card

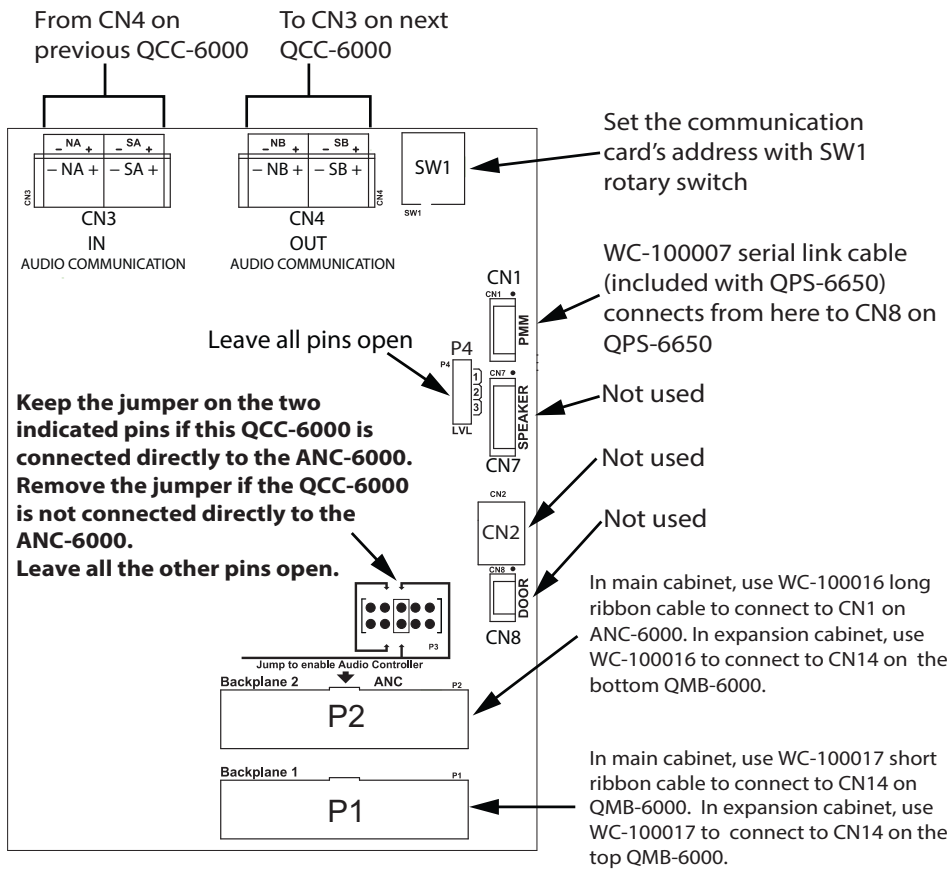

Attention: Keep the jumper on the 2 indicated pins if this QCC-6000 is connected directly to the ANC-6000. Remove the jumper if the QCC-6000 is not connected directly to the ANC-6000. Leave all the other pins open.

Rotary switch SW1 is set starting from 0 to 9 for each expansion cabinet. Maximum 10 per node. The QCC-6000 in the main enclosure must be set to 0.

Figure 51 QCC-6000 Rotary Switch

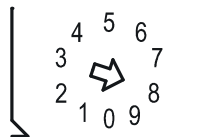
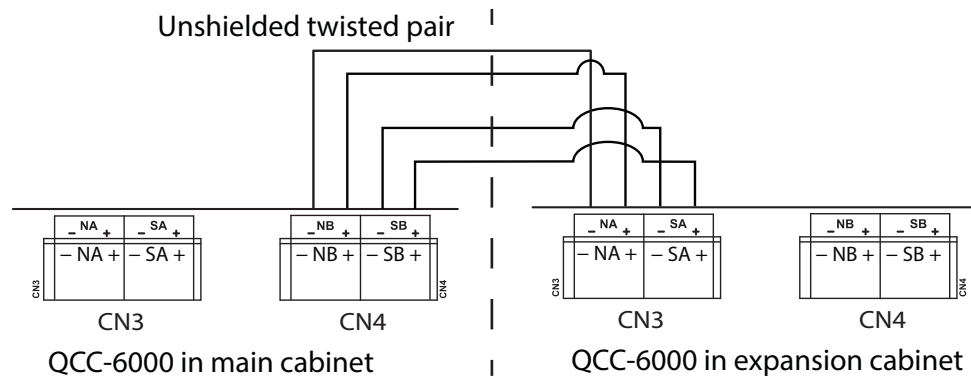

Figure 52 Field Wiring between QCC-6000s Class B



Maximum wiring length between QCC-6000s: 2000 feet (610 m)

Wire gauge: 18-22 AWG

Figure 53 Installing the QCC-6000 Communications Card.

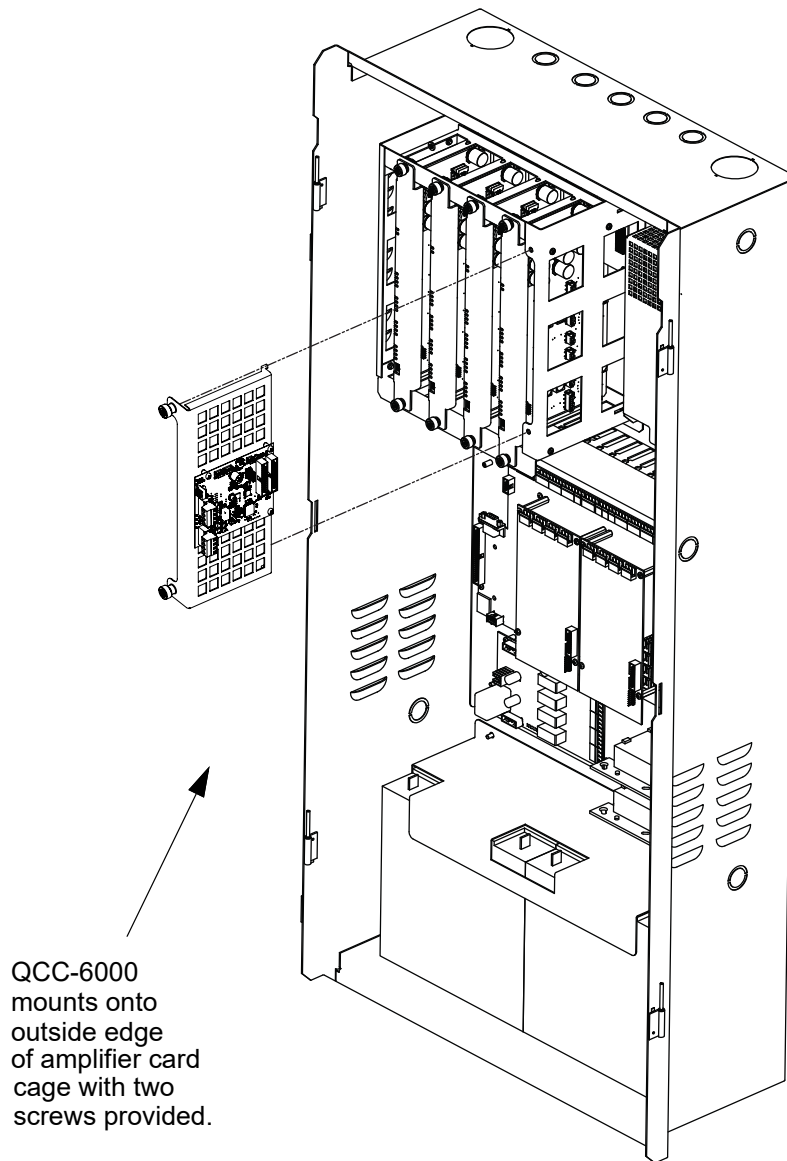

Figure 54 QCC-6000 Communications Class B Wiring

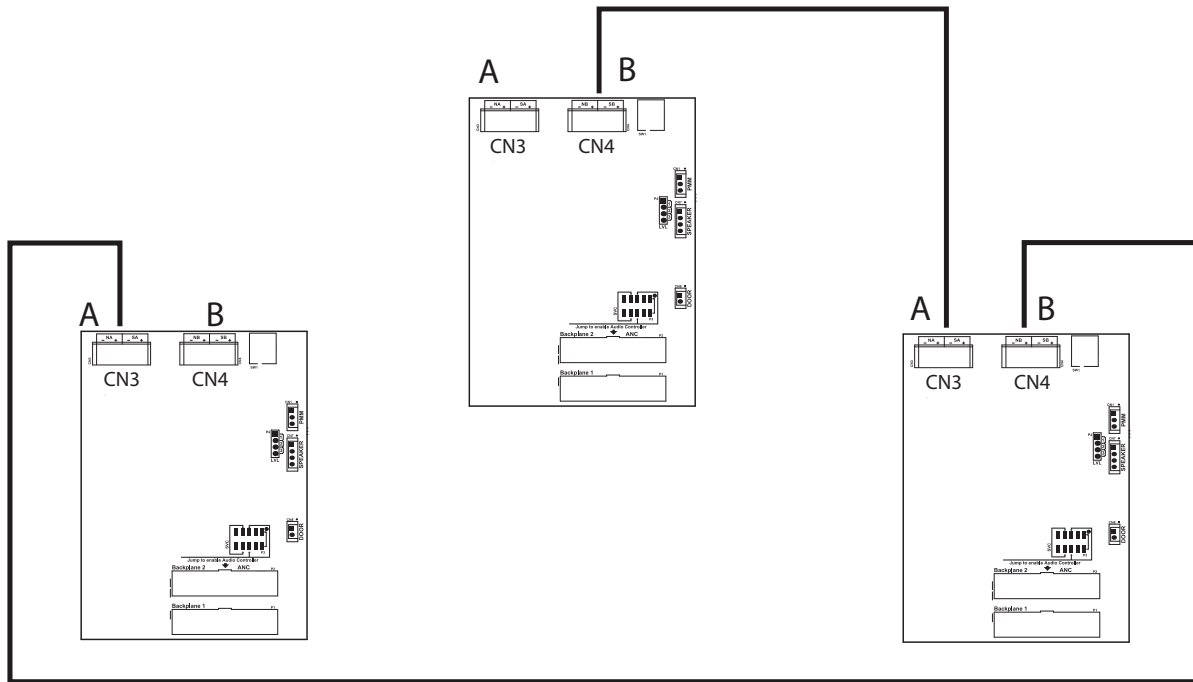
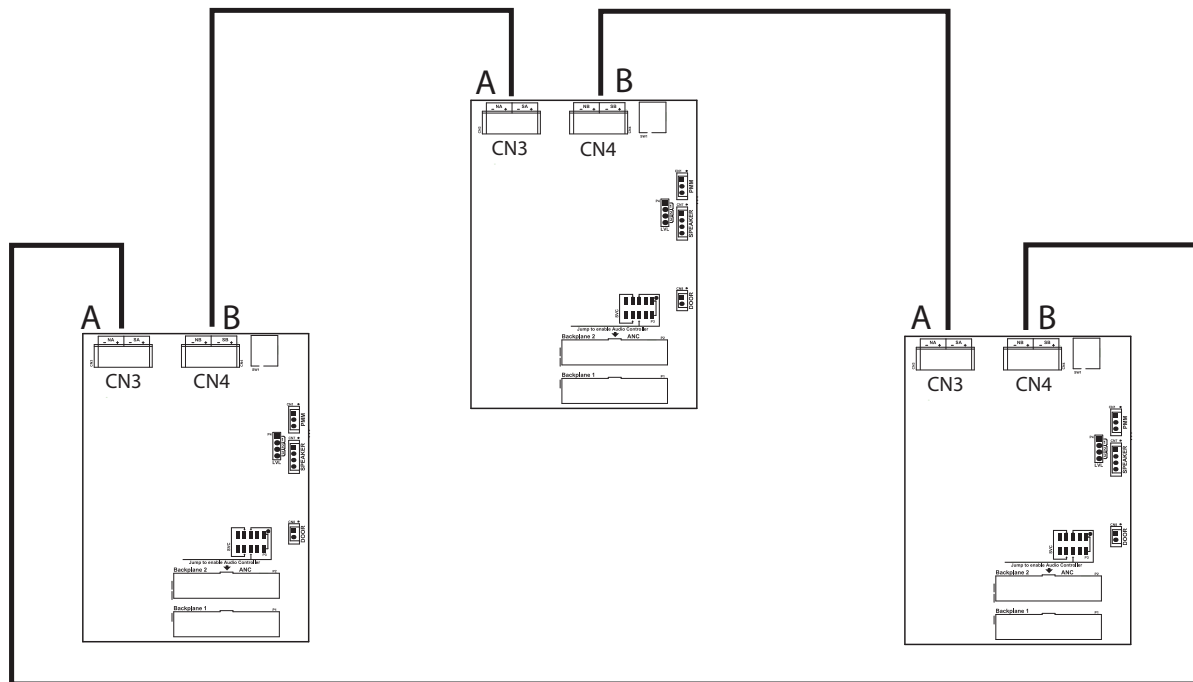

Figure 55 QCC-6000 Communications Class A Wiring



6.4 ANC-6000 Audio Network Controller Board and TNC-5000 Telephone Network Card

Each QMB-6000 backplate requires an ANC-6000 Audio Network Controller Board. The TNC-5000 Telephone Controller Network card is necessary only if telephone circuits are required. Below is a diagram for mounting both audio and telephone cards over the main fire alarm board in FX-6000MNS-CH.

The ANC-6000 can be mounted in positions 2, 3, or 4.

The FNC-2000 can be mounted in positions 1 or 2.

The TNC-5000 must be mounted over the ANC-6000.

Figure 56 Mounting the Audio and Telephone Card over the Main Fire Alarm Board in FX-6000MNS-CH

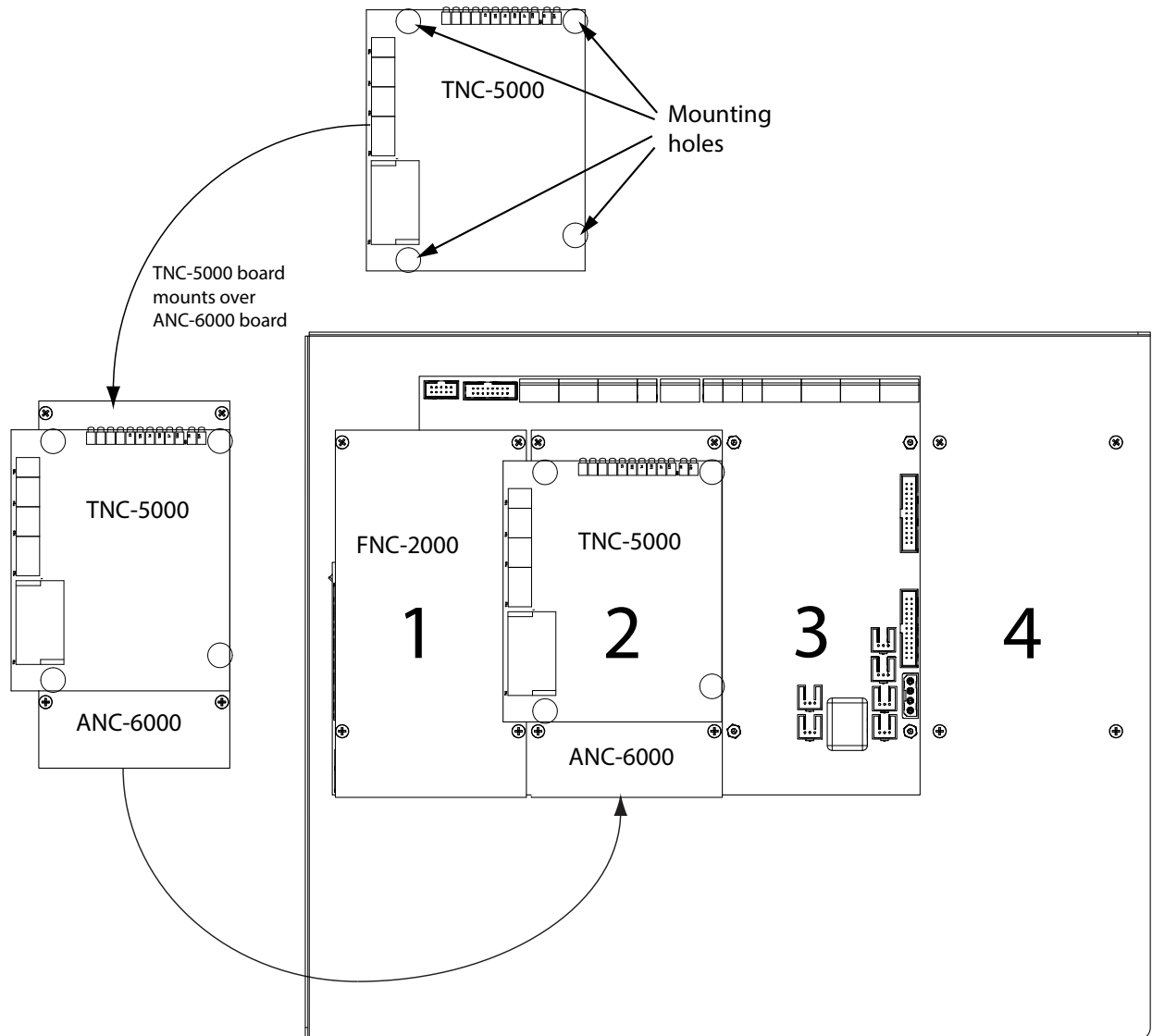

6.5 ANC-6000 Audio Network Controller Board

Figure 57 ANC-6000 Audio Network Controller board

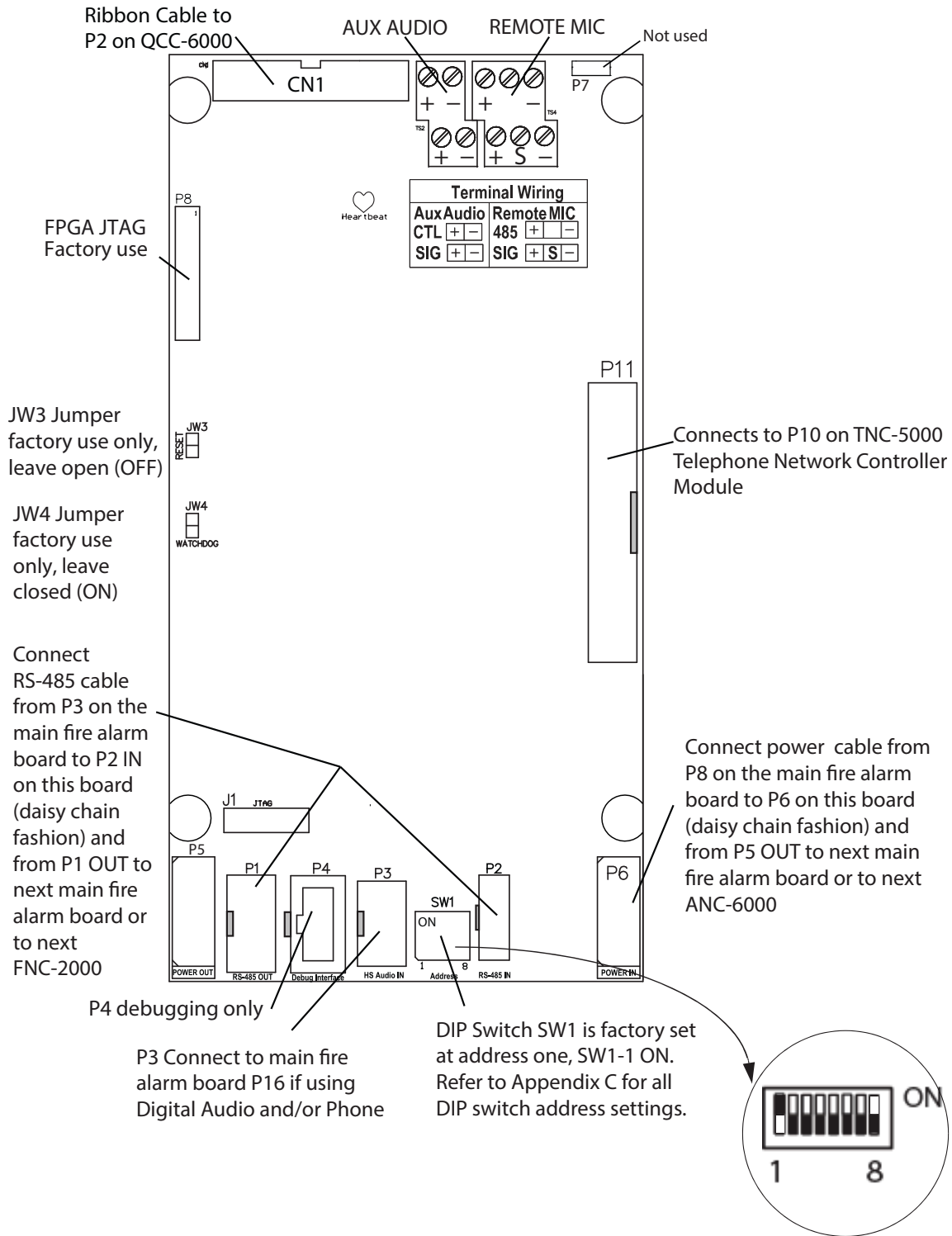

6.6 ANC-6000 Wiring

The auxiliary audio input has a maximum input of 1 VRMS. The transformer is isolated on the ANC-6000.

Connect an audio source, for example background music or paging, to the SIG terminal. Connect a normally open relay and 3.9 k Ω resistor to the CTL terminal as shown in Figure 58. Short the relay to activate the auxiliary audio.

See section 7.3 for details on wiring the ANC-6000 to the QMP-6101N(V).

Figure 58 ANC-6000 Wiring Diagram

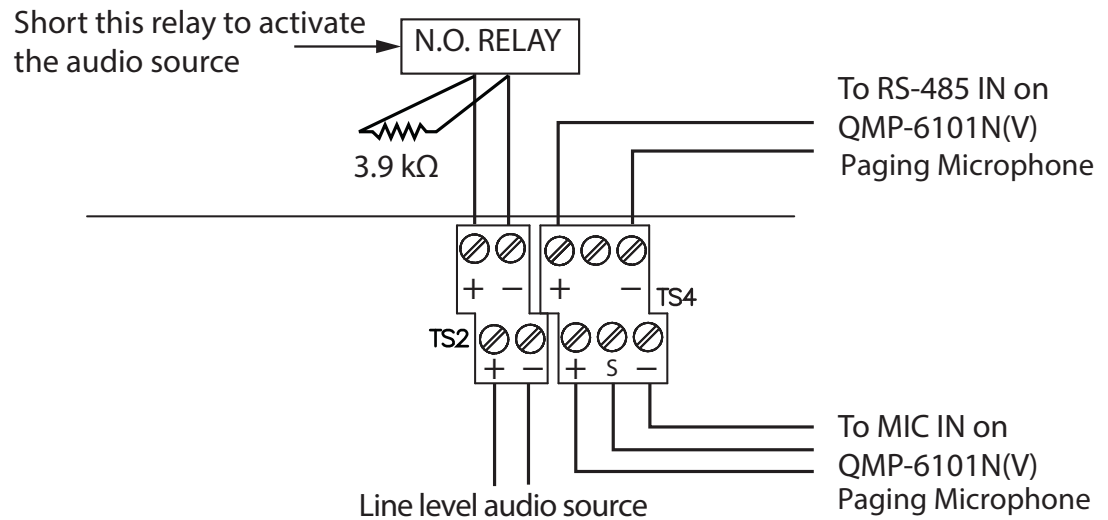

7.0 QMP-6101N(V) Paging Control Modules

7.1 QMP-6101NV Vertical Paging Control Module

The QMP-6101NV Vertical Paging Control Module fits into the BBX-FXMNS-6000 Enclosure. It mounts on the inside door chassis.

Refer to Figure 58 and Figure 62 for wiring instructions.

Slide-in labels NP-8200 are placed so that push buttons and LEDs are labelled as shown in Figure 59.

Figure 59 QMP-6101NV Vertical Paging Control Module

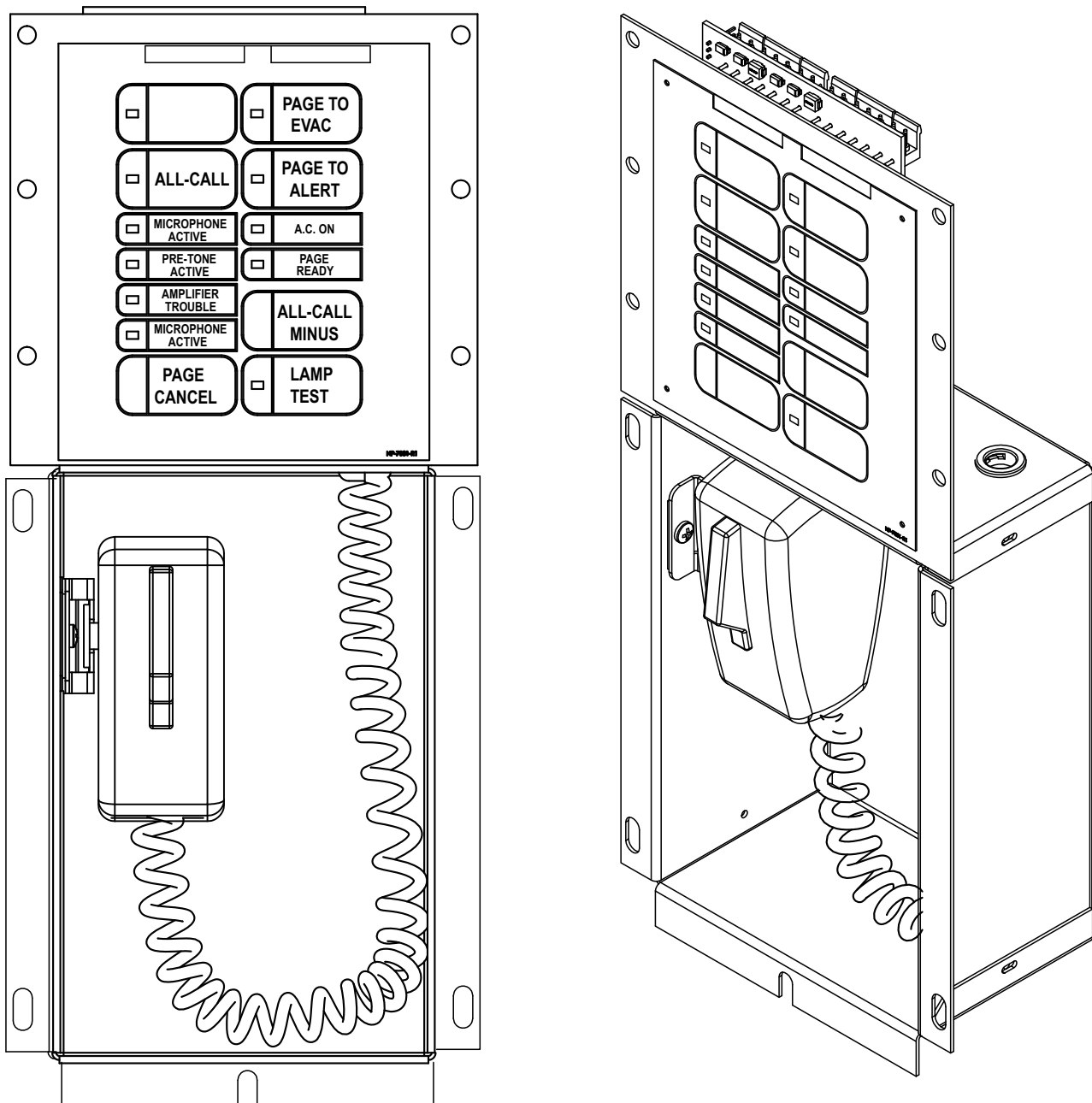

7.2 QMP-6101N Horizontal Paging Control Module

The QMP-6101N Horizontal Paging Control Module mounts into the BB-5008 and BB-5014.

Refer to Figure 61 for mounting and Figure 58 and Figure 62 for wiring instructions.

Slide-in labels NP-8200 are placed so that push buttons and LEDs are labelled as shown in Figure 60.

Figure 60 QMP-6101N Horizontal Paging Control Module

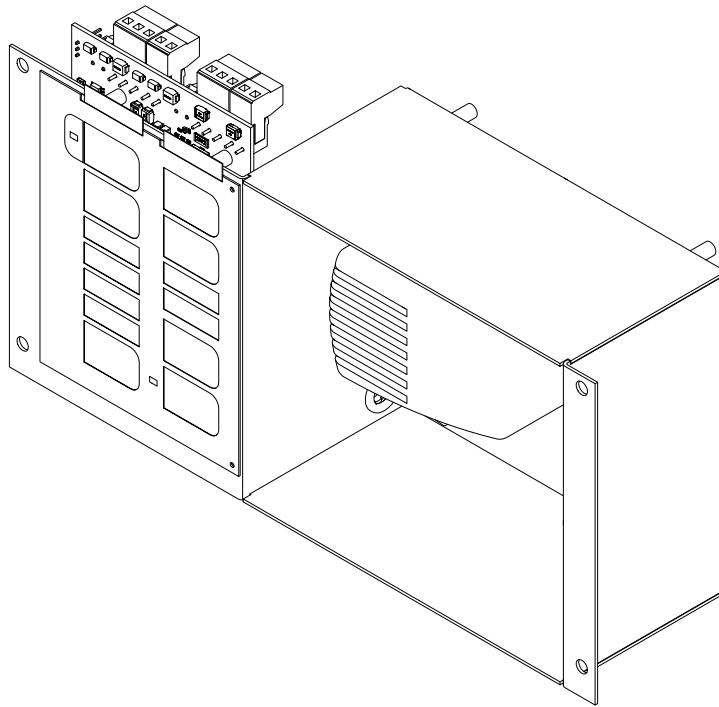
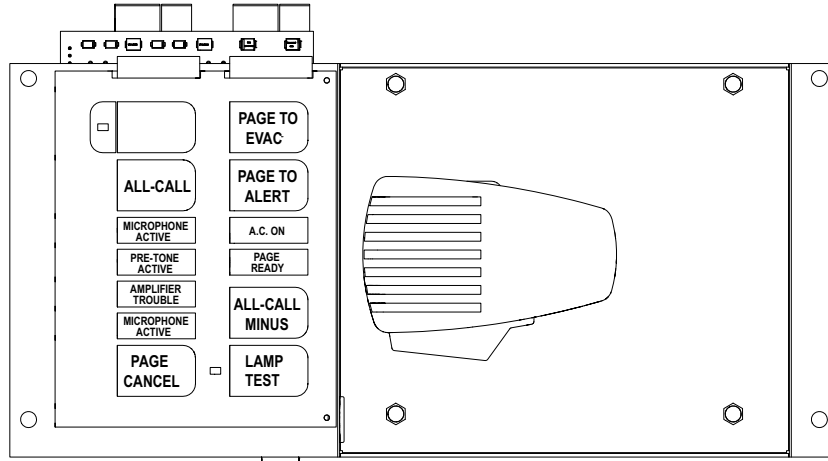
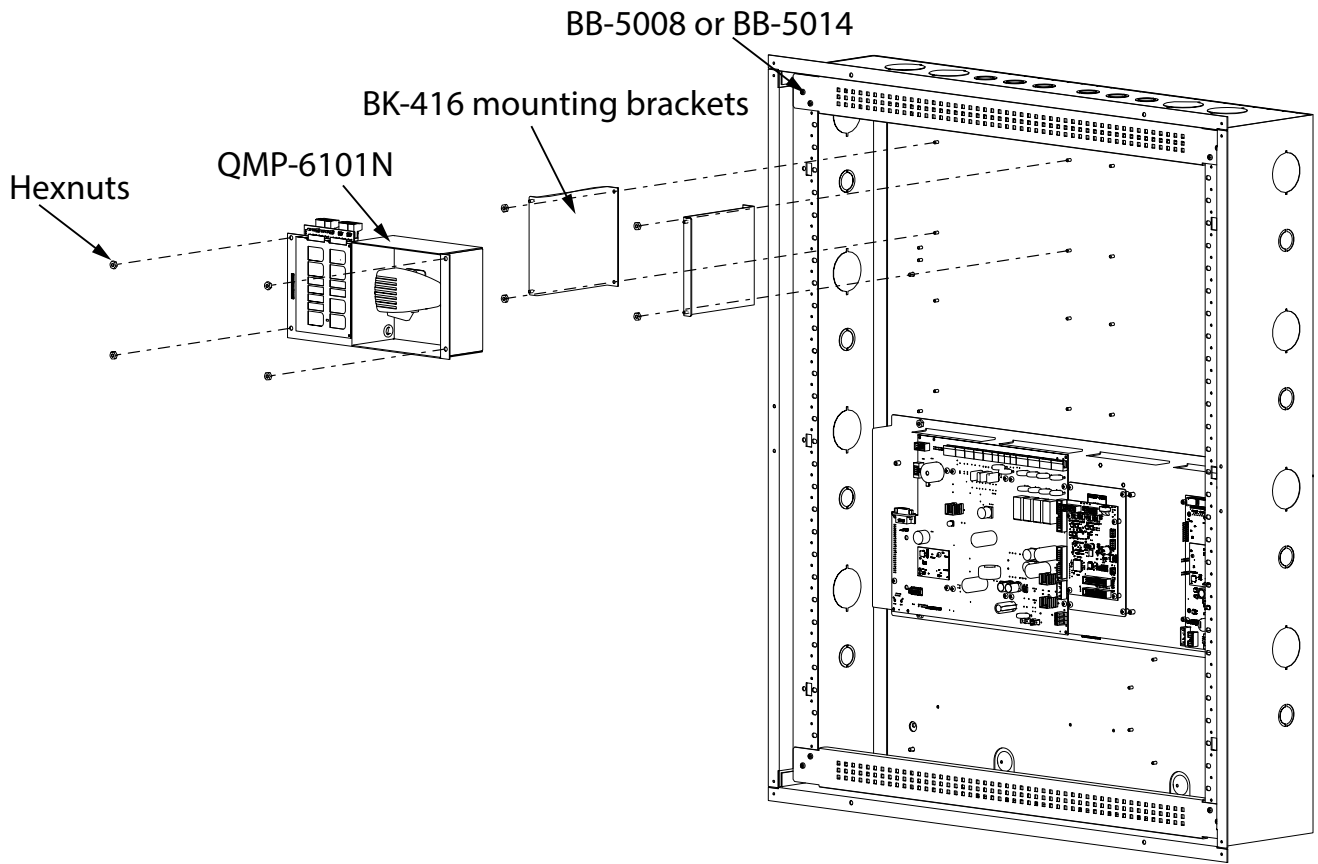
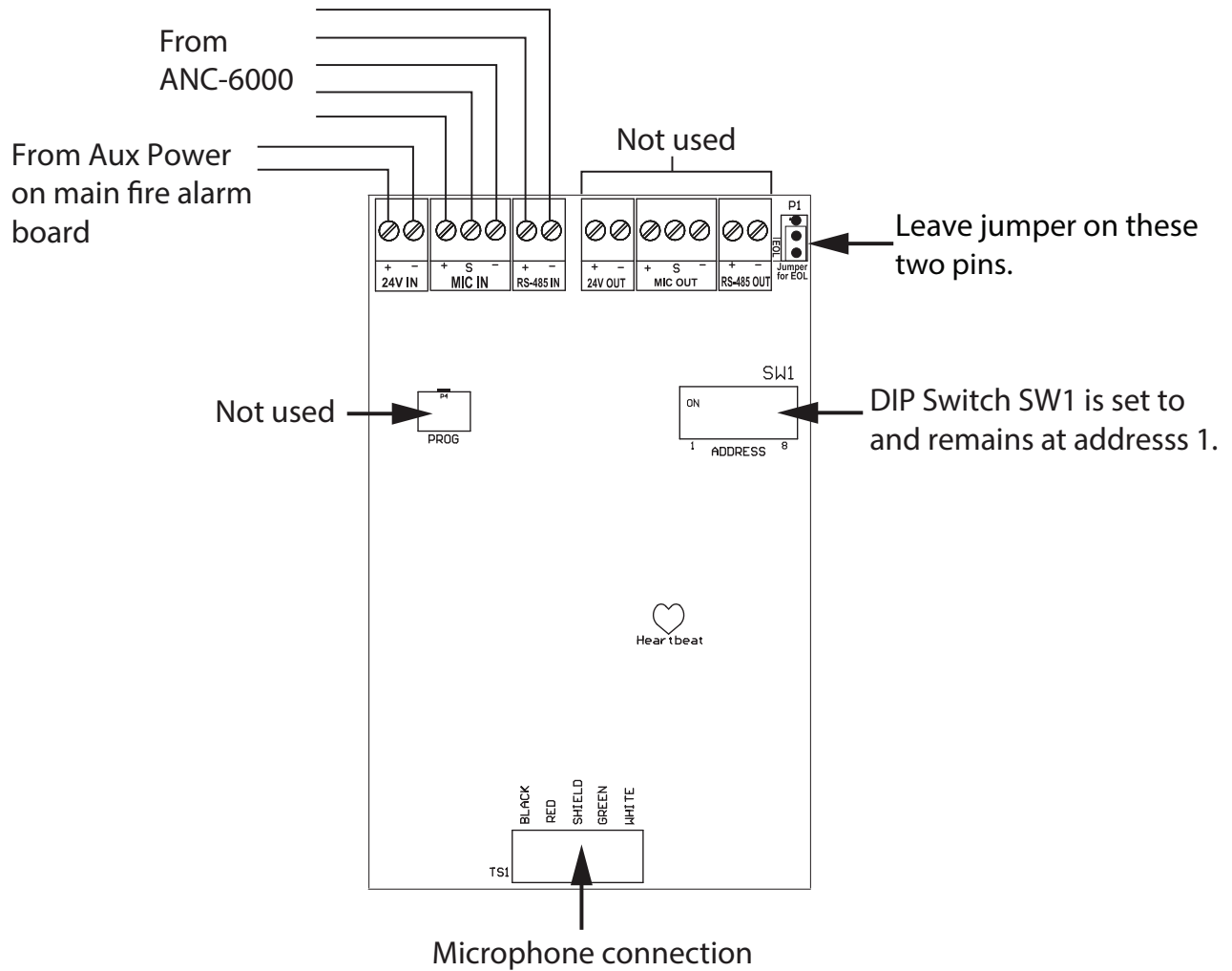

Figure 61 QMP-6101N Horizontal Paging Control Module Mounting



7.3 Wiring

Figure 62 QMP-6101N and QMP-6101NV Paging Control Module Connections and Terminal Blocks



See section 6.6 for details on the connection to the ANC-6000.

The interface wiring between the ANC-6000 and QMP-6101N(V) is as follows:

Table 19: ANC-6000 and QMP-6101N(V) Wiring

24V +, -	18-22 AWG Twisted Pair
MIC+, MIC-, SHLD:	18-22 AWG Twisted Shielded Pair
RS-485	18-22 AWG Twisted Pair

The maximum wiring run from the ANC-6000 and QMP-6101N(V) is 20 feet or 6 metres.

8.0 QAZT-5302DS and QAZT-5348DS Zoned Paging Selector Panels

Each QAZT-5302DS annunciates and controls up to 24 audio zones. Each QAZT-5348DS annunciates and controls up to 48 audio zones. There is one button and two LEDs per zone. The lower amber LED indicates Zone trouble. The upper green LED indicates whether that zone is selected for voice paging via the master microphone.

Paging zone selection buttons toggle ON and OFF voice paging for that zone.

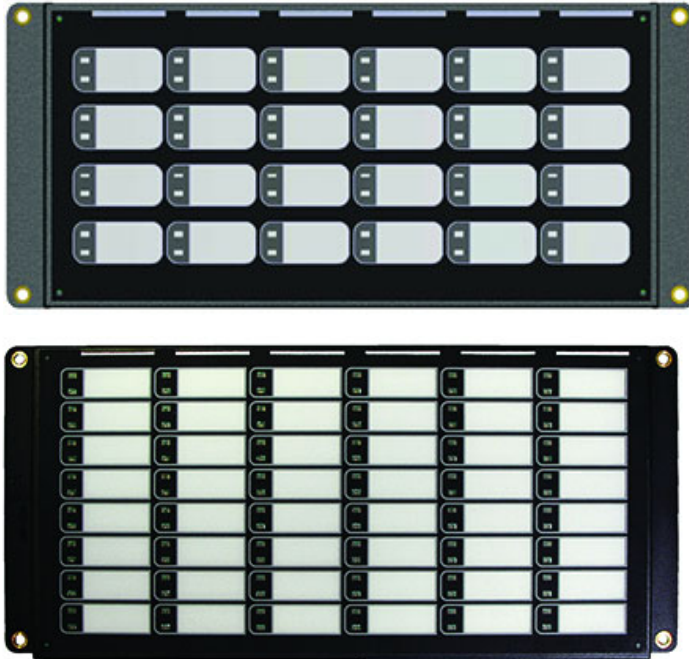

Figure 63 QAZT-5302DS (top) and QAZT-5348DS (bottom)

9.0 Paging Operation

This section describes the controls and indicators on the QMP-6101N(V) Master Paging Microphone Module and the QAZT-5302DS and QAZT-5348DS Paging Selector Modules.

9.1 QMP-6101N(V) LEDs

9.1.1 All Call

Illuminates steady green to indicate that the All-Call function is active.

9.1.2 Microphone Active LED

Flashes green to indicate any activity (i.e. other microphone in use). Illuminates steady green when associated microphone (at proximity of LED) is in use.

9.1.3 Pre-Tone Active LED

Steady amber when paging is active.

9.1.4 Amplifier Trouble LED

Indicates any amplifier internal trouble.

9.1.5 Microphone Trouble LED

Flashes amber to indicate a microphone trouble.

9.1.6 Page to Evac LED

Illuminates steady green when the Page to Evac pushbutton is active.

9.1.7 Page to Alert LED

Illuminates steady green when the Page to Alert pushbutton is active.

9.1.8 AC ON LED

This green LED illuminates steadily to indicate that AC power is present.

9.1.9 Page Ready LED

Illuminates steady green when the push-to-talk (PTT) on the microphone is depressed (active) and the system is ready for paging.

9.1.10 Lamp Test LED

This amber LED illuminates steadily to indicate that the Lamp Test has been activated.

9.2 QMP-6101N(V) Pushbutton Controls

9.2.1 All-Call Button

Selects all zones for voice paging.

9.2.2 All-Call Minus Button

Inverts the selection of zones for voice paging.

9.2.3 Page to Evac

Pressing this button selects all the amplifiers currently in evacuation mode, for paging.

9.2.4 Page to Alert

Pressing this button selects all the amplifiers currently in alert mode, for paging.

9.2.5 Page Cancel

Pressing this button de-selects all zones (including those manually selected) from paging.

9.2.6 Lamp Test Button

Flashes all LED indicators.

9.2.7 Microphone PTT Button

The microphone's PTT (push-to-talk) button is located on the microphone itself. When depressed, allows voice paging (from the microphone) to be enabled to all zones selected for paging, unless page cancel is active. Note that pressing PTT will not result in any paging activity unless there are zones selected for paging.

9.3 QAZT-5302DS and QAZT-5348DS Paging Selector Panel LEDs

9.3.1 Page LED

Illuminates green if the zone is selected for voice paging.

9.3.2 Trouble LED

Flashes amber to indicate that the zone is in trouble.

9.4 QAZT-5302DS and QAZT-5348DS Pushbutton Controls

9.4.1 Page Button (if enabled)

Selects / deselects that zone for voice paging.

10.0 TNC-5000 Telephone Network Controller Module

10.1 Module Mounting Locations

The TNC-5000 Telephone Network Controller board can be mounted in one place. The TNC-5000 Telephone Network Controller Board is mounted above the ANC-6000 Audio Network board, both are mounted in position 2 above the main fire alarm board, see Figure 56.

10.2 Typical Addressable Telephone Set-up

The typical addressable telephone set-up is with an addressable fire alarm system using the TNC-5000 and from the TNC-5000 to the Master Telephone (QMT-5302NV). The selector panels (QAZT-5348DS) are connected to the Master Telephone by cable only. The MIX-M500FP(A) Control Modules are connected to the addressable loop from the quad loop adder module and to each other and the Master Telephone. Remote telephones are connected to the control modules.

Figure 64 Typical Addressable Telephone Set-up

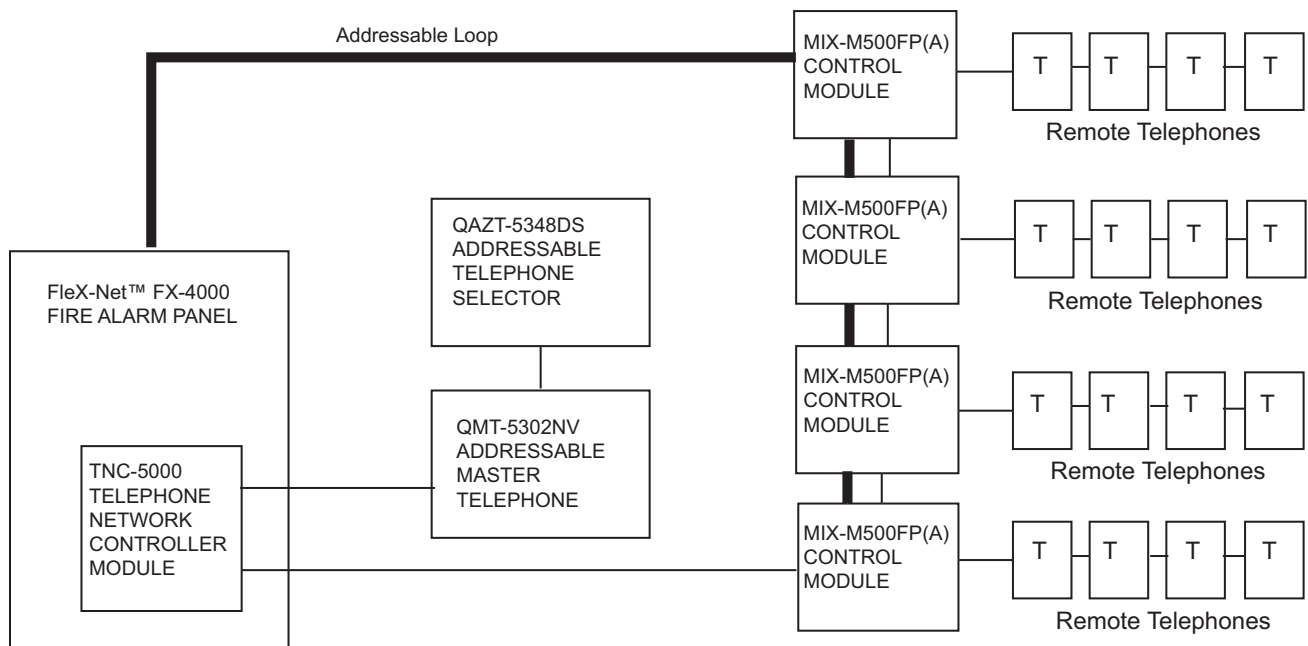

10.3 Connectors and Terminal Locations

Table 20 shows the cable connections and jumpers required and additional wiring. Refer to Figure 65 for connector and terminal locations.

Table 20: Connectors on TNC-5000

TNC-5000 Connector and Terminals	Connects to
P10 Cable	P11 on the ANC-6000 Audio Network Controller Module.
Z1 Terminals	These two terminals are wired to the Master Telephone if used, otherwise to any telephone zone.
Z2, Z3, Z4 and Z5 Terminals	These terminals are wired to telephone zones.
Telephone Bus In and Out Terminals	Wire from previous TNC-5000 to next TNC-5000. Total cable resistance is 50 Ω maximum, 18 gauge twisted pair. Telephone Bus is power limited and fully supervised.
JW1	Jumper positions 1 and 2 if zone 1 is connected to a Master Telephone.
JW1	Jumper positions 2 and 3 if zone 1 is NOT connected to a Master Telephone.

Figure 65 TNC-5000 Telephone Network Controller Board Layout

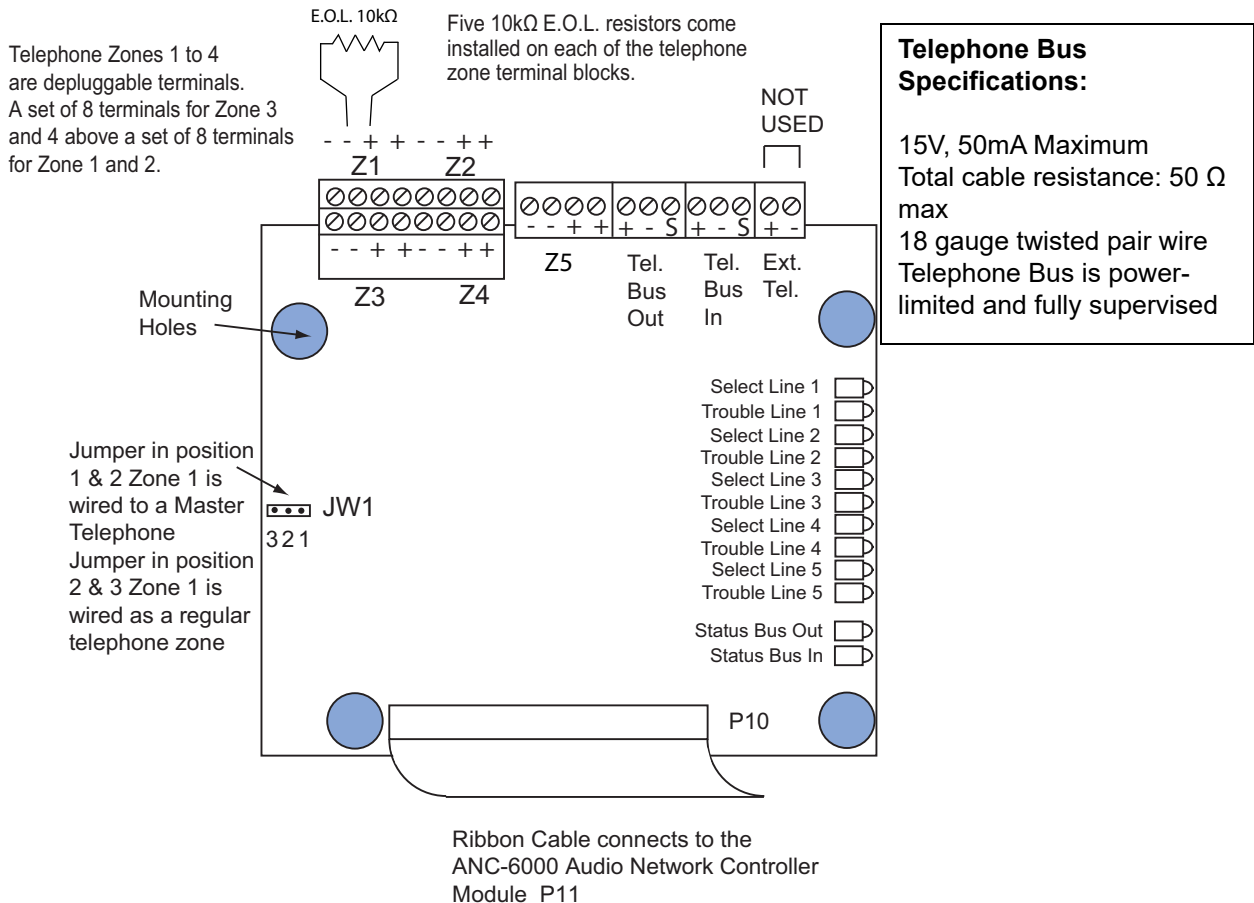

10.4 TNC-5000 Telephone Wiring

Figure 66 Telephone Bus Wiring Diagram

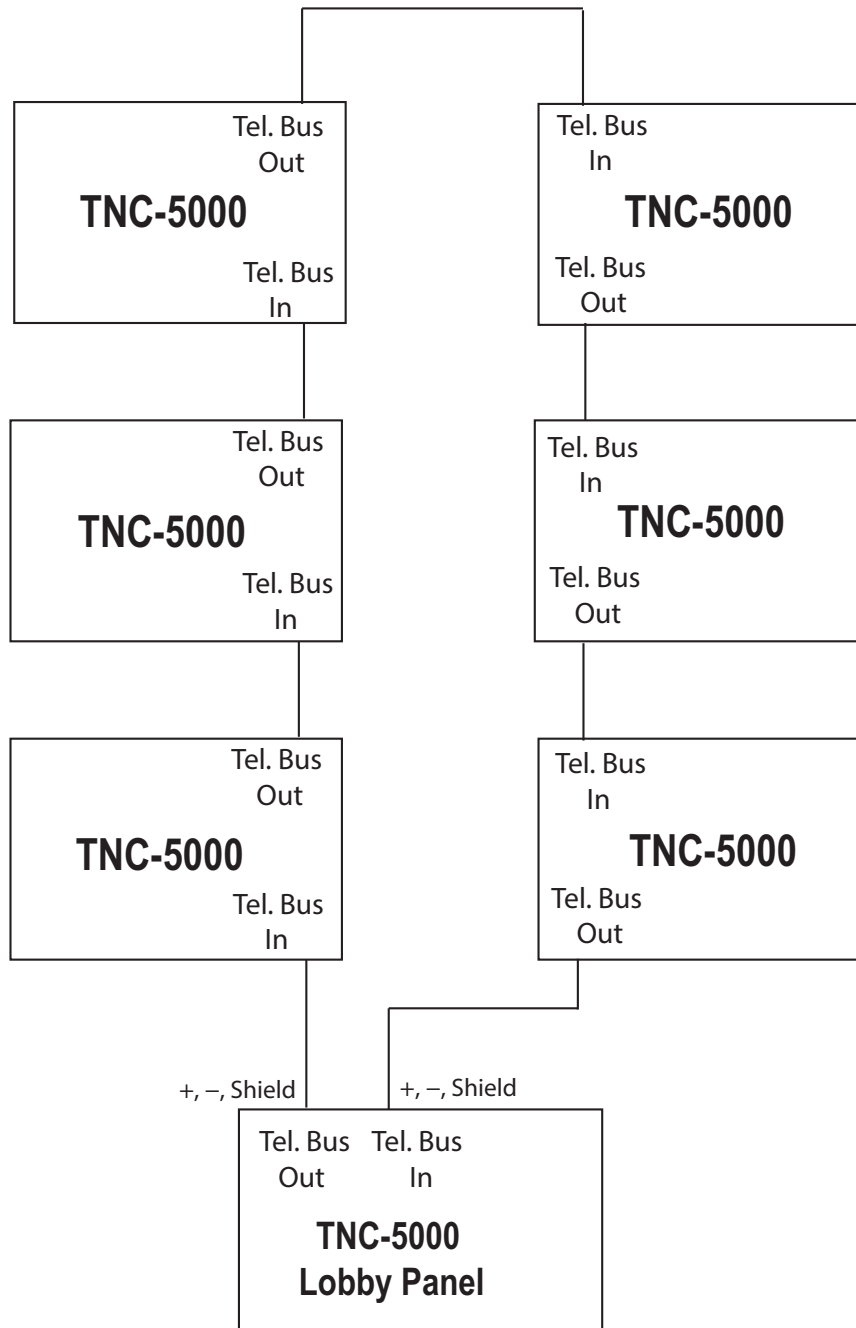

Zones 1 to 5 are wired to telephones via MIX-M500FP(A) addressable control modules. Only Zone 1 is wired to the Master Telephone (if used) at the main fire alarm center, otherwise Zone 1 is wired as another telephone zone when a master telephone is not required.

Figure 67 TNC-5000 Telephone Zone Wiring

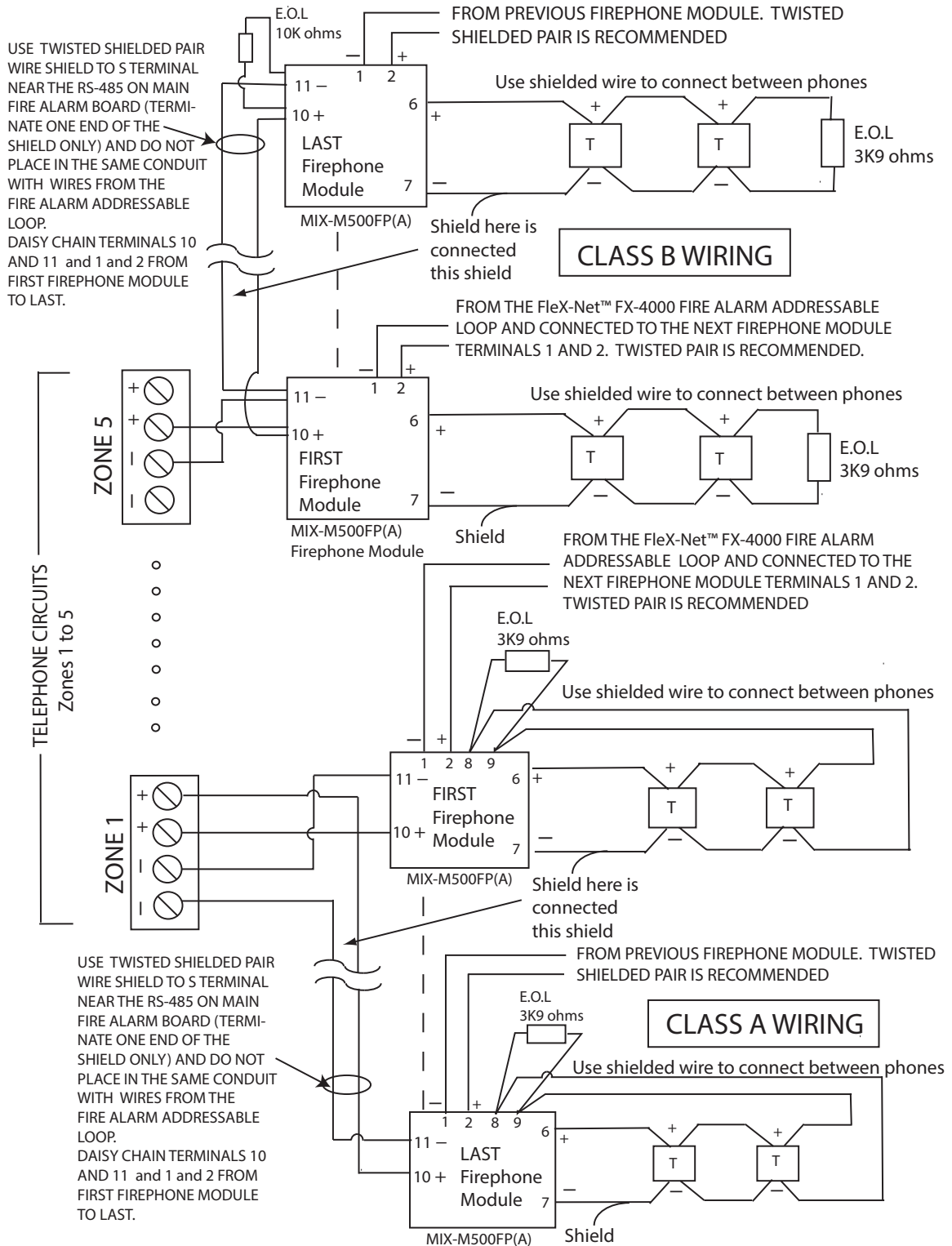

10.5 QMT-5302NV Vertical Master Telephone

The QMT-5302NV Vertical Master Telephone Module fits into the BBX-FXMNS-6000 Enclosure. The master telephone is mounted to the inside door chassis.

Figure 68 QMT-5302NV Master Firefighters' Telephone

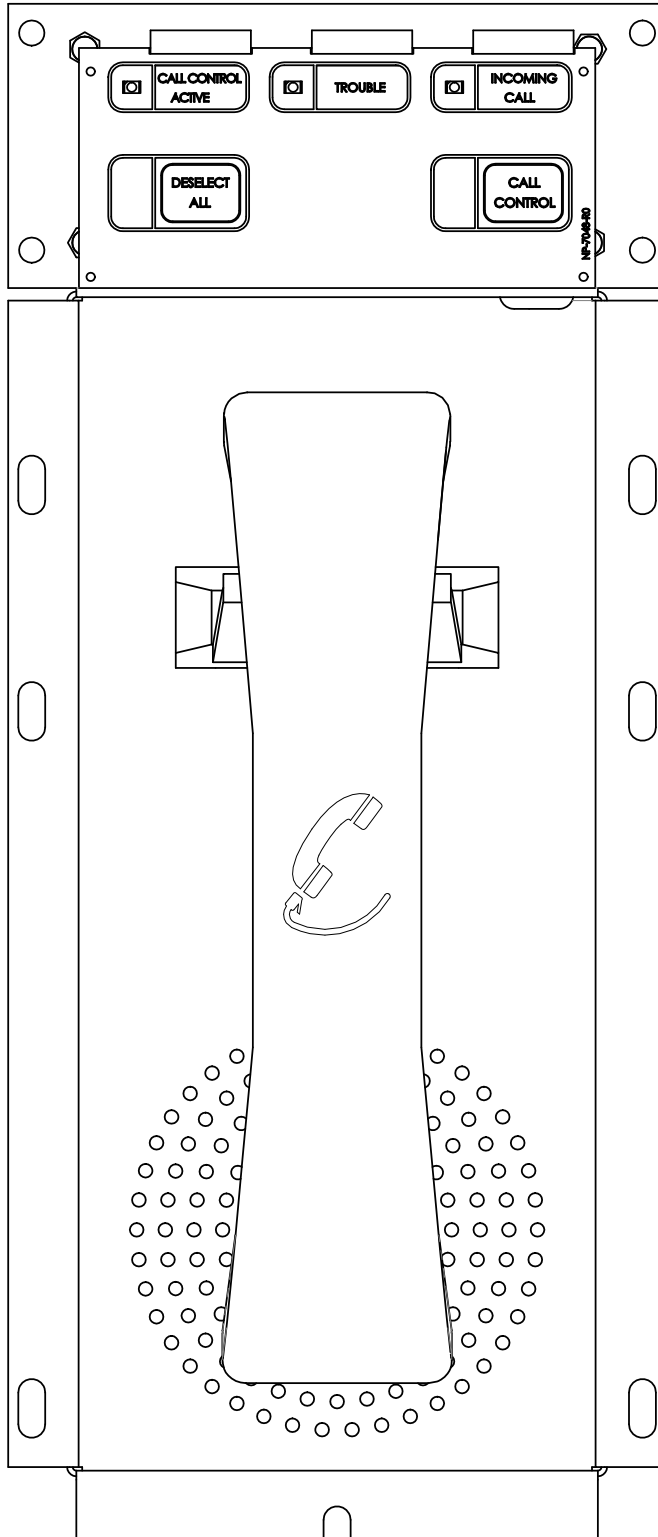

10.6 QMT-5302NV Connections

The connections required on the QMT-5302NV Network Master Firefighters' Telephone Control Module are the cable from the previous display module to P1 or IN connector on the bottom left of the board and the OUT connection goes to the IN connector of the next display board.

The master telephone positive and negative terminals connect to the TNC-5000 Zone 1 positive and negative terminals with twisted shielded pair wires. Refer to Figure 69 below for connector and terminal block locations of the QMT-5302NV.

Figure 69 QMT-5302NV Cable Connection and Terminal Wiring

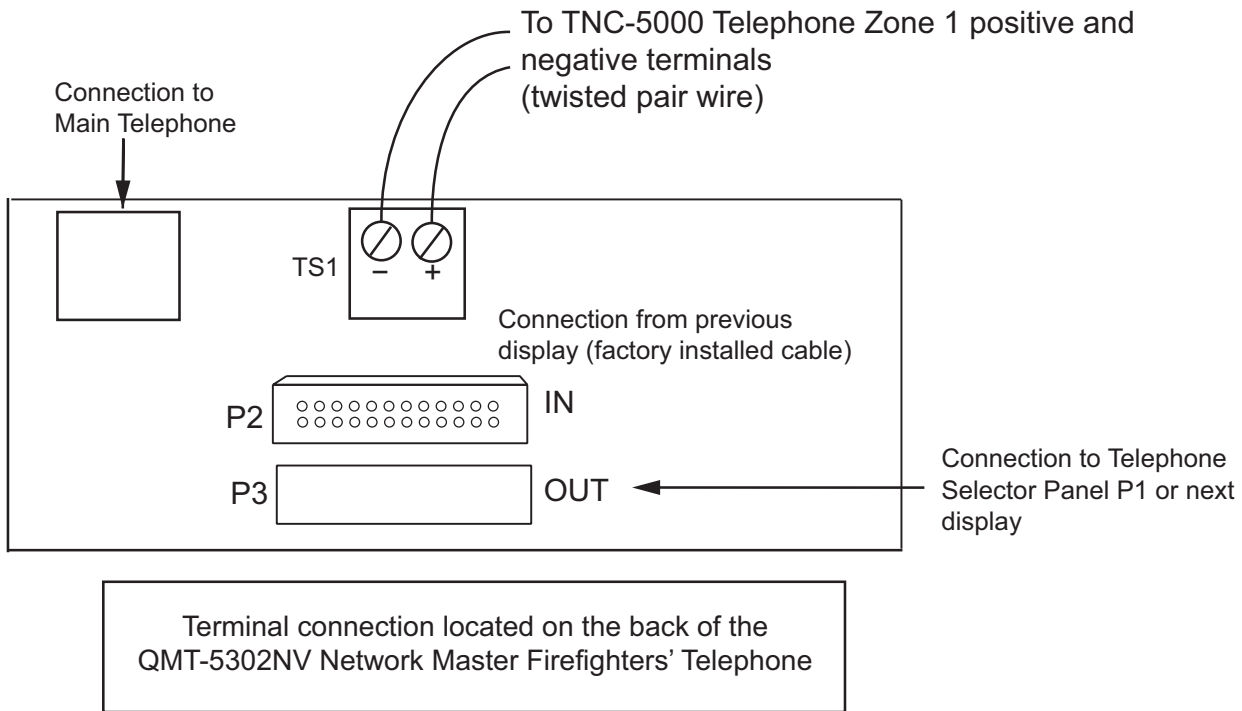

10.7 QAZT-5348DS Network Firefighters' Telephone Selector Panel

Figure 70 QAZT-5348DS Network Firefighters' Telephone Selector Panel

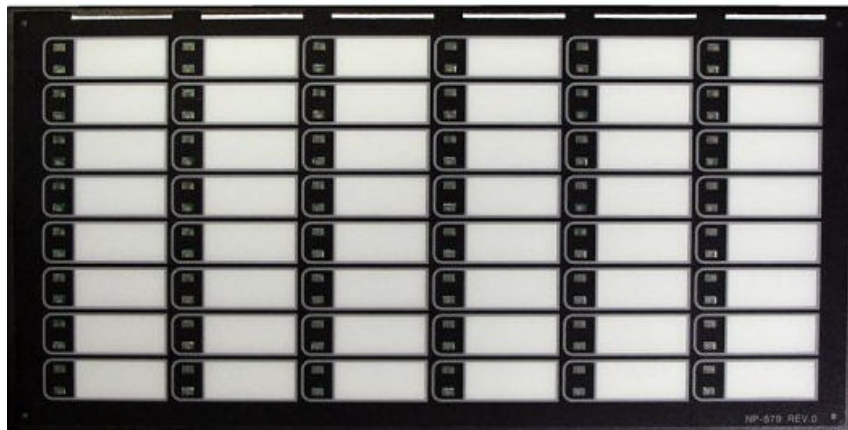

Each QAZT-5348DS annunciates and controls up to 48 telephone zones. There is one button and two LEDs per zone. The lower amber LED indicates zone trouble. The upper green LED indicates whether that zone is selected for telephone communication.

Telephone zone selection buttons toggle ON and OFF telephone communication for that zone.

i

Note: Use configurator to set up the QAZT-5348DS Telephone Zone Selector Panels.

Connect the first QAZT-5348DS Network Firefighters' Telephone Selector panel to the master telephone by connecting the Ribbon In cable into P2 on the QMT-5302NV Master Telephone. Ribbon Out cable to the Ribbon In of the next QAZT-5348DS or P1 of the next display panel (up to six total). See Figure 71 below.

i

Note: All modules such as the QMP-6101N(V) Network Master Paging Control Module, the QMT-5302NV Network Master Firefighters' Telephone Control Module, the IPS-4848DS display module and the paging or telephone selector panel QAZT-5348DS are daisy chained together starting from the LCD display panel module, DSPL-420DS, DSPL-2440DS, RAXN-4000LCD, RAXN-4000LCDG or RAXN-4000LCDGC. Total number of boards allowed in the daisy chain connection is 6 (12 frames).

Figure 71 QAZT-5348DS Telephone Selector Panel Cable Connections

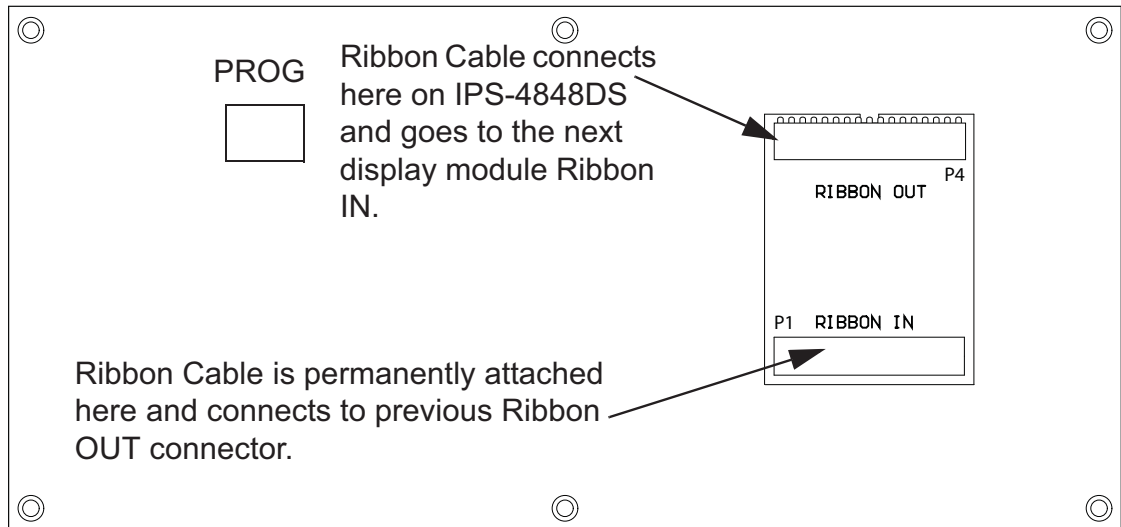

10.8 Telephone Operation

When any telephone zone rings (the local buzzer sounds intermittently, and the green zone LED and Incoming Call LED flash) press that zone's button (on the selector panel QAZT-5348DS) once to answer. Once any one zone has been answered, calls from any other zone will cause that zone's green LED and the Incoming Call LED at the master telephone to flash and the buzzer will sound.

Press the answered zone's button once again to hang up. (Note that the telephone zone will hang up automatically if all handsets on the zone are placed back on the hook).

10.9 QMT-5302NV Master Telephone LEDs

10.9.1 Trouble LED

This LED will flash amber if there is any zone or other trouble in the firefighters' telephone system.

10.9.2 Incoming Call LED

This LED will flash green if any telephone zone has a handset off-hook and unanswered. It will illuminate steady green if all telephone zones with off-hook handsets have been answered.

10.9.3 Call Control Active LED

This LED will illuminate when there is a connection between the designated Master Telephone (at the CACF) and the present QMT-5302NV telephone.

10.10 QMT-5302NV Master Telephone Pushbutton Controls

10.10.1 Call Control

Pressing this pushbutton will connect this master telephone with master telephones as configured.

10.10.2 Deselect All

Pressing this pushbutton will disconnect all master telephone calls initiated at this node (Call Control minus).

10.11 QAZT-5348DS Network Telephone Selector Panel LEDs

10.11.1 Telephone Zone Green LED

This LED will flash green if there is any handset off-hook on that zone, and the zone has not been answered by pressing the zone's button. Once answered, the LED will be steady green.

10.11.2 Telephone Zone Amber LED

This LED will flash amber to indicate trouble on open-circuit zone faults (e.g. missing end-of-line resistor or wire breaks) or short-circuit zone faults.

10.12 QAZT-5348DS Network Telephone Selector Panel Pushbuttons

10.12.1 Telephone Selection Pushbutton

Pressing the telephone selector pushbutton will select the associated telephone to be connected to the Master Telephone. Pressing this button a second time will hang up.

11.0 Audio Amplifier Wiring

There are two 100 watt amplifiers available, a 70V version and a 25V version.

Table 21 Audio Amplifier Wiring

Amplifier	Description
QAD-6425-70	One 100 watt supervised speaker circuit, 70V or One 75 watt and one 25 watt supervised speaker circuits, 70V or Two 50 watt individually supervised speaker circuits, 70V or One 50 watt and two 25 watt individually supervised speaker circuits, 70V or Four 25 watt individually supervised speaker circuits, 70V
QAD-6425-25	One 100 watt supervised speaker circuit, 25V or One 75 watt and one 25 watt supervised speaker circuits, 25V or Two 50 watt individually supervised speaker circuits, 25V or One 50 watt and two 25 watt individually supervised speaker circuits, 25V or Four 25 watt individually supervised speaker circuits, 25V

11.1 Amplifier Mounting Installation

Install amplifiers as shown in Figure 72 below.

Figure 72 Installing the Amplifiers into the QMB-6000 Card Cage

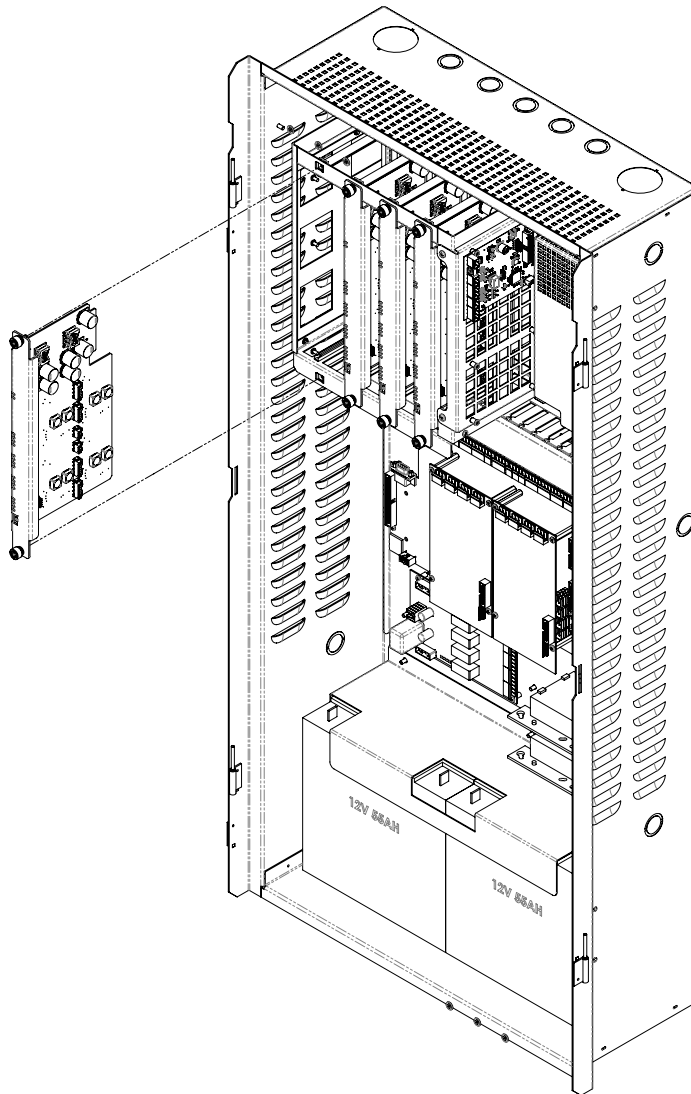

The QMB-6000 card cage provides the terminals for the amplifier field wiring. There are 4 slots for the amplifier cards, and 4 sets of terminals for the speaker wiring. Figure 73 shows the correlation between the slots for the amplifier cards and the terminals for the speakers.



Note: Slot 4 is recommended for the backup amplifier for ease of wiring.

Figure 73 QMB-6000 Terminals for Amplifier Wiring

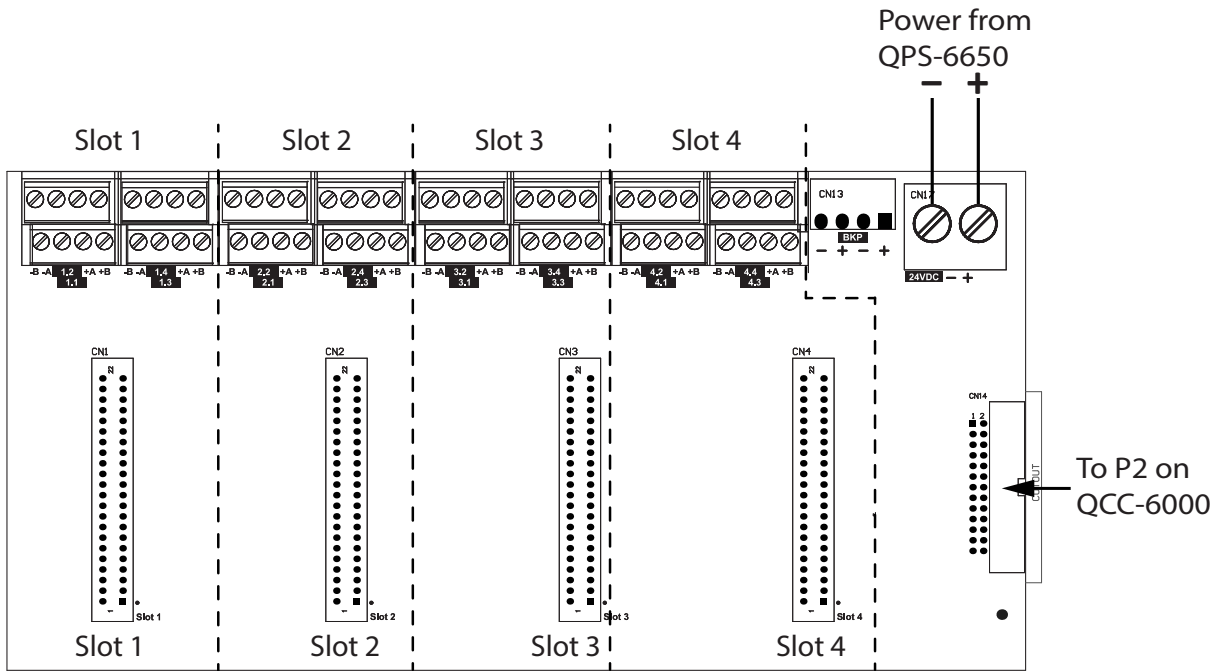

11.2 Amplifier Wiring

11.2.1 QAD-6425-25/QAD-6425-70 Amplifier Wiring (100W Circuit)

The QAD-6425-25/QAD-6425-70 amplifier module can be configured as one 100 Watt supervised speaker output and placed in any of the four available card slots of the QMB-6000.

Any 100W circuit may be wired as Class A or Class B. Must use terminal block x.1 for field wiring where x denotes card slot used.

Figure 74 Wiring for 100 Watt Amplifier Circuit

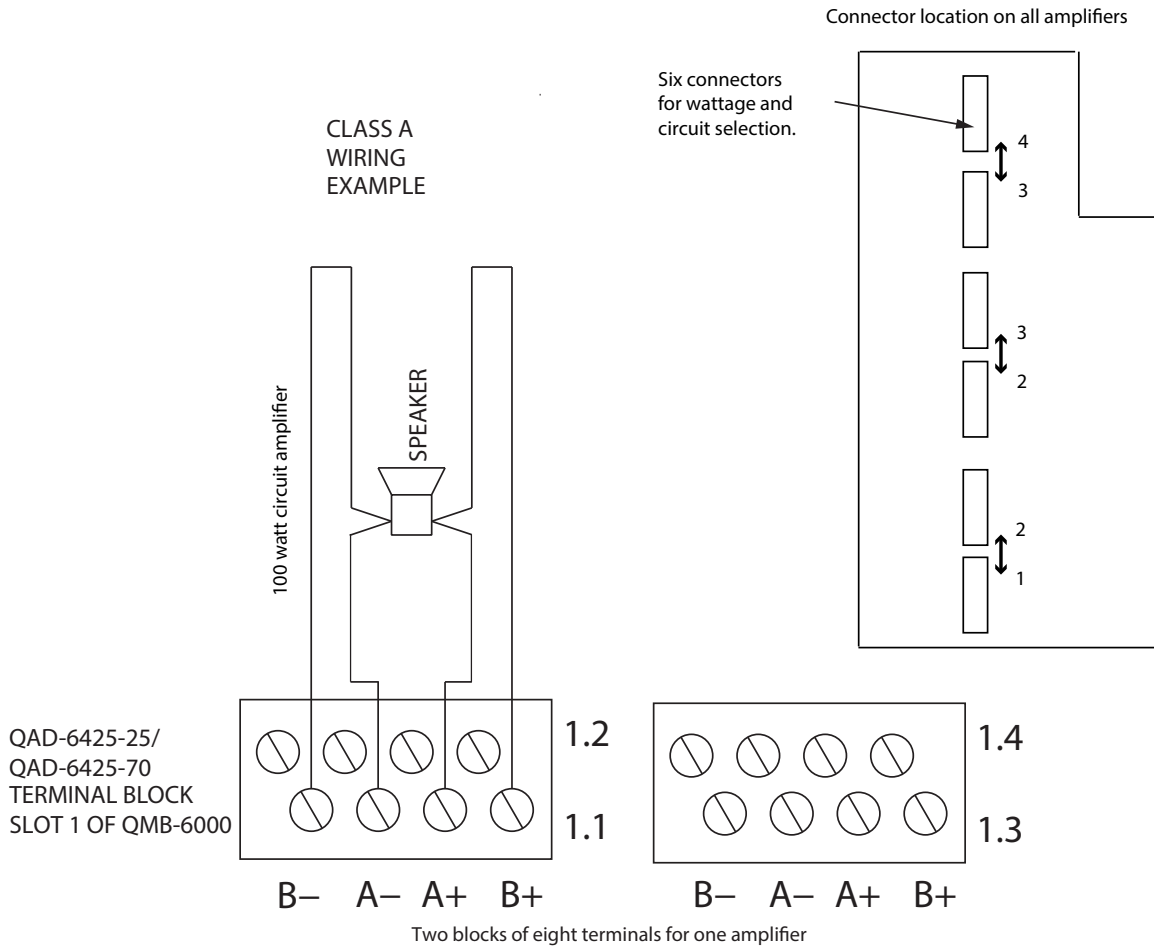

Notes:

- Must use terminal block x.1 for 100W circuit wiring. For example, if the 100W circuit amplifier is in slot 1, wire the 100W speakers to terminal 1.1. Nothing should be wired to terminals 1.2, 1.3, and 1.4.
- For one 100W circuit place all 3 jumpers (WC-10008) on the connectors marked 1 and 2, 2 and 3, and 3 and 4 on the amplifier.
- All circuits are power limited and supervised.
- See speaker wiring charts (Table 24 and Table 25) for wire gauge selection.
- Refer to Table 26 for proper end of line resistor values.



11.2.2 QAD-6425-25/QAD-6425-70 Amplifier Wiring (75W and 25W Circuits)

The QAD-6425-25/QAD-6425-70 amplifiers can be wired as one 75 watt and one 25W supervised speaker output. Each circuit may be wired as Class A or Class B.

Figure 75 Wiring for 75W and 25W Amplifier Circuits

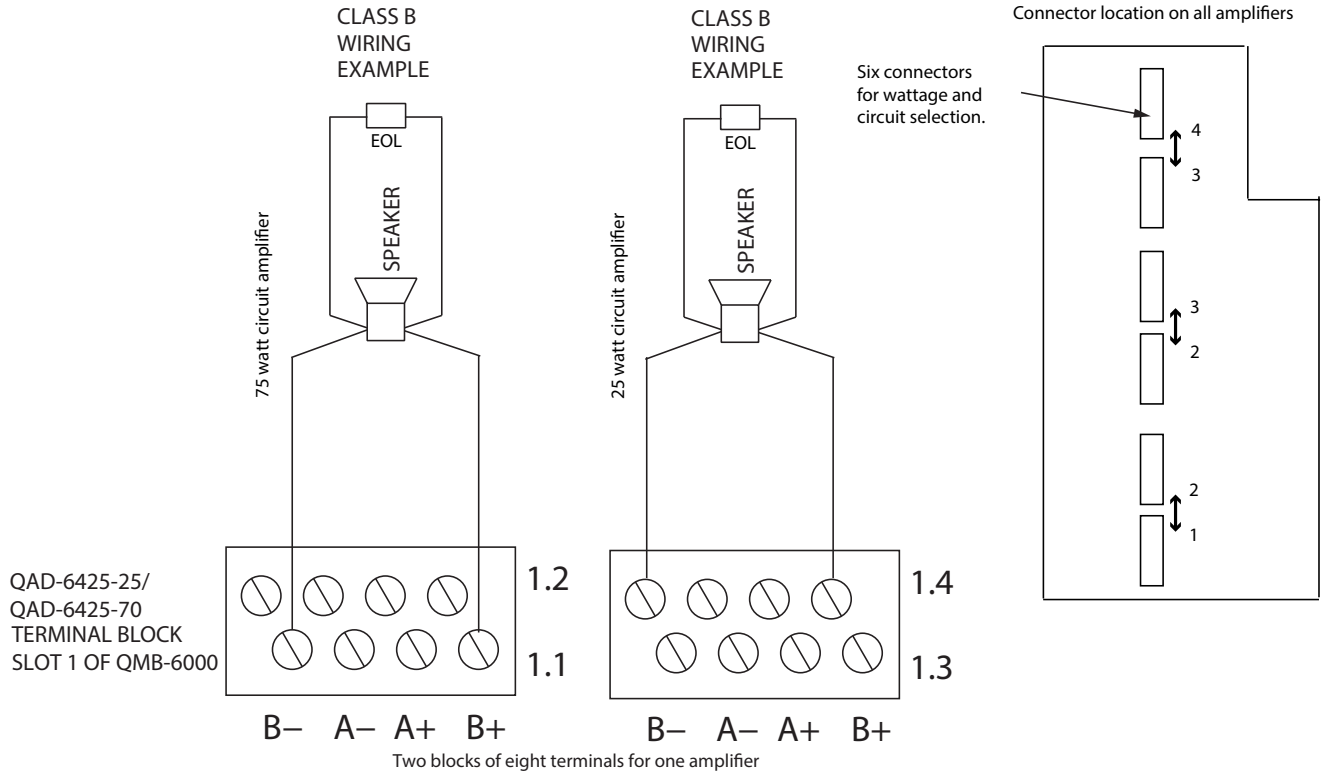

Notes:

- The terminals that the speakers are wired to depend on the jumper settings. See Table 22. See Figure 75 for the jumper connections.
- All circuits are power limited and supervised.
- See speaker wiring charts (Table 24 and Table 25) for wire gauge selection.
- Refer to Table 26 for proper end of line resistor values.

Table 22: Wiring of 75W and 25W Speakers

Configuration 1	
Jumper settings	Wire Speakers to
2-3, 3-4	Wire 25W speakers to x.1
	Wire 75W speakers to x.2
	Nothing wired to x.3 and x.4
Configuration 2	
Jumper settings	Wire Speakers to
1-2, 2-3	Wire 75W speakers to x.1
	Nothing wired to x.2 and x.3
	Wire 25W speakers to x.4

11.2.3 QAD-6425-25/QAD-6425-70 Amplifier Wiring (50W Circuits)

The QAD-6425-25/QAD-6425-70 amplifiers can be wired as one or two 50 watt supervised speaker outputs. Each 50W circuit may be wired as Class A or Class B.

Figure 76 Wiring for 50W Amplifier Circuits

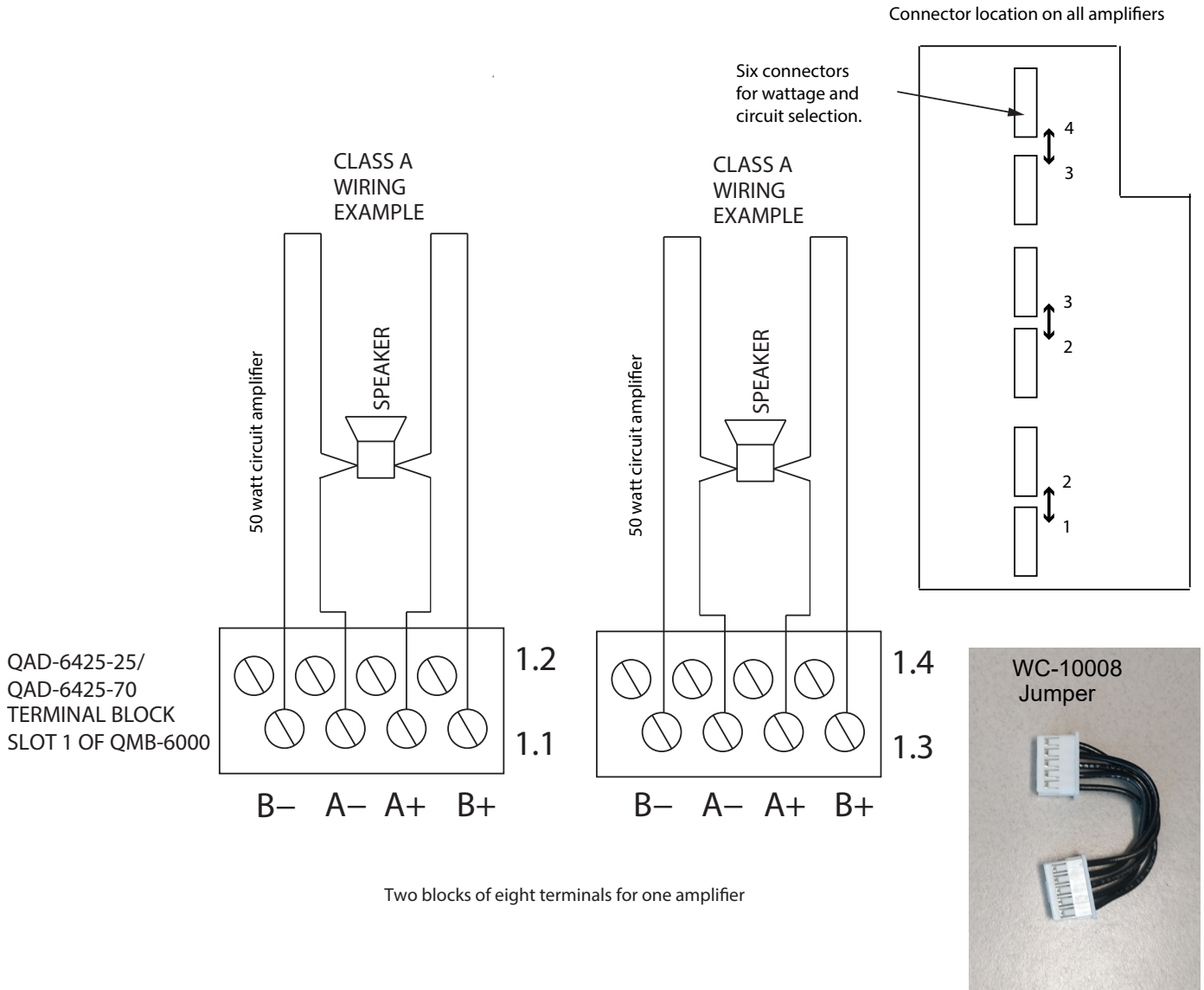

Notes:



- The terminals that the speakers are wired to depend on the jumper settings. See Table 23. See Figure 76 for the jumper connections.
- All circuits are power limited and supervised.
- See speaker wiring charts (Table 24 and Table 25) for wire gauge selection.
- Refer to Table 26 for proper end of line resistor values.

Table 23: Wiring of 50W and 25W Speakers

Configuration 1	
Jumper settings	Wire Speakers to
3-4	Wire 25W speakers to x.1
	Wire 25W speakers to x.2
	Wire 50W speakers to x.3
	Nothing wired to x.4
Configuration 2	
Jumper settings	Wire Speakers to
2-3	Wire 25W speakers to x.1
	Wire 50W speakers to x.2
	Nothing wired to x.3
	Wire 25W speakers to x.4
Configuration 3	
Jumper settings	Wire Speakers to
1-2	Wire 50W speakers to x.1
	Nothing wired to x.2
	Wire 25W speakers to x.3
	Wire 25W speakers to x.4
Configuration 4	
Jumper settings	Wire Speakers to
1-2, 3-4	Wire 50W speakers to x.1
	Nothing wired to x.2
	Wire 50W speakers to x.3
	Nothing wired to x.4

For example, to configure an amplifier card in slot 1 as **Configuration 1** (25W/25W/50W), put one jumper on the connectors marked 3 and 4 and leave the other connectors open. Wire the 25W speakers to terminals 1.1 and 1.2. Wire the 50W speakers to terminals 1.3. Nothing should be wired to 1.4.

11.2.4 QAD-6425-25/QAD-6425-70 Amplifier Wiring (25W Circuits)

The QAD-6425-25/QAD-6425-70 amplifiers can be wired as four 25 watt supervised speaker outputs. Each 25W circuit may be wired as Class A or Class B.

Figure 77 Wiring for 25W Amplifier Circuits

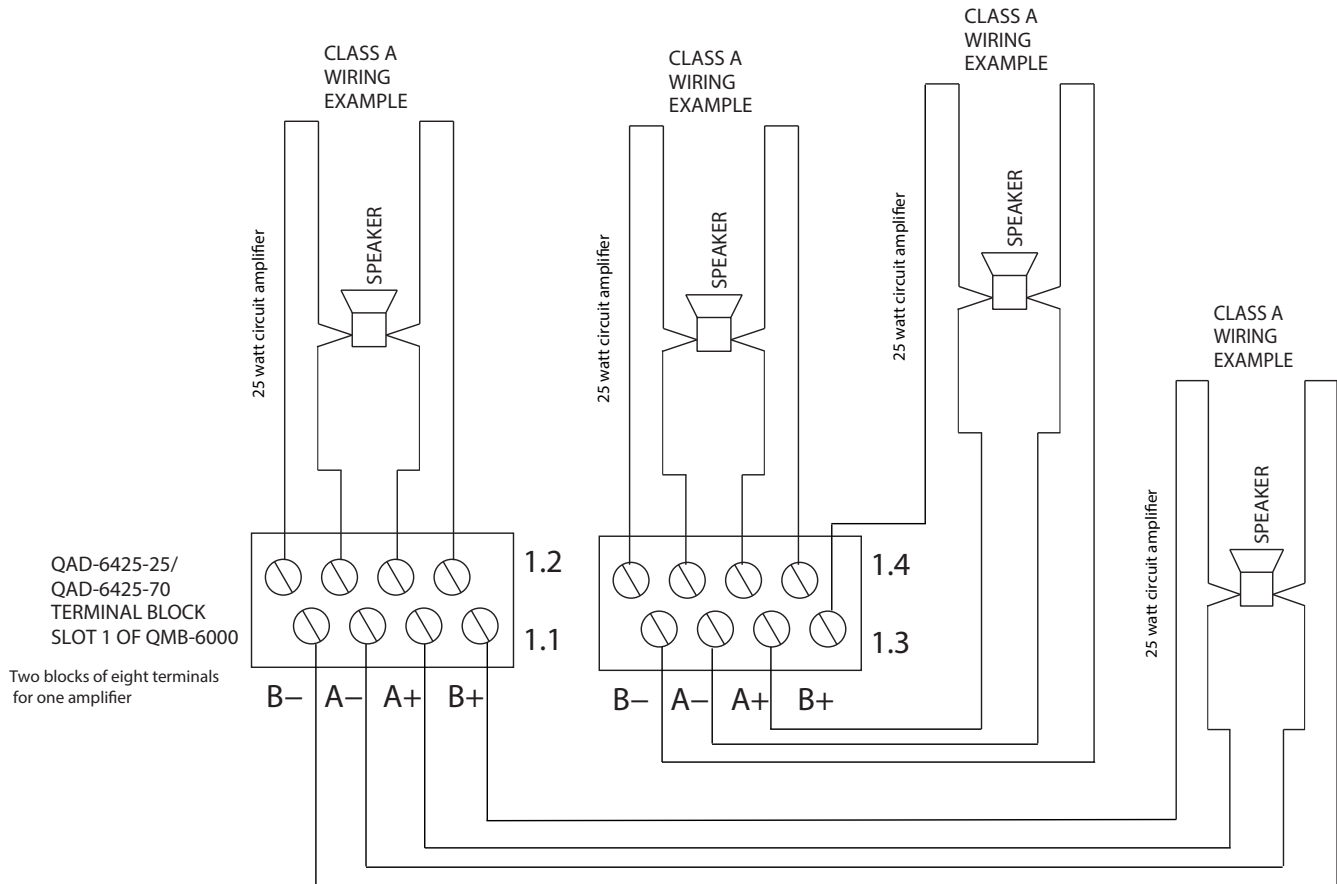

Notes:

- Use terminal block 1.1, 1.2, 1.3 and 1.4 for four 25W circuit wiring.
- For four circuits of 25 watts, DO NOT use any of the jumpers (WC-10008) on the connectors on the amplifier.
- All circuits are power limited and supervised.
- See speaker wiring charts (Table 24 and Table 25) for wire gauge selection.
- Refer to Table 26 for proper end of line resistor values.



11.2.5 Backup Amplifier Wiring

Any amplifier circuit may be designated as a backup amplifier circuit when backup is required. One backup amplifier circuit is allowed per node. The backup amplifier circuit can be in any amplifier installed in any audio cabinet. Only the first failed amplifier circuit gets the backup. The backup amplifier circuit is set up by configuration. Select one amplifier circuit on a backplate and it will be a backup circuit for the other amplifier circuits on the node.

The backup amplifier circuit can be configured as 25W, 50W, 75W, or 100W. It must have the same or greater wattage as the other amplifier circuits. For example, if the system has a 100W amplifier circuit, then the backup amplifier circuit must be 100W.

The designated backup amplifier circuit must be wired to the Backup Bus Supervision Continuation terminals and the other terminals of this connector to the next backplate. For class B wiring, the End of Line resistor for the backup amplifier should be connected at the last backplate (see Table 26).



Note: Use the backup amplifier only if all the audio cabinets are in the same room.

Figure 78 and Figure 79 show class A and class B wiring for a 25W backup amplifier on circuit 4.4.

Figure 78 Backup Amplifier Class A Wiring

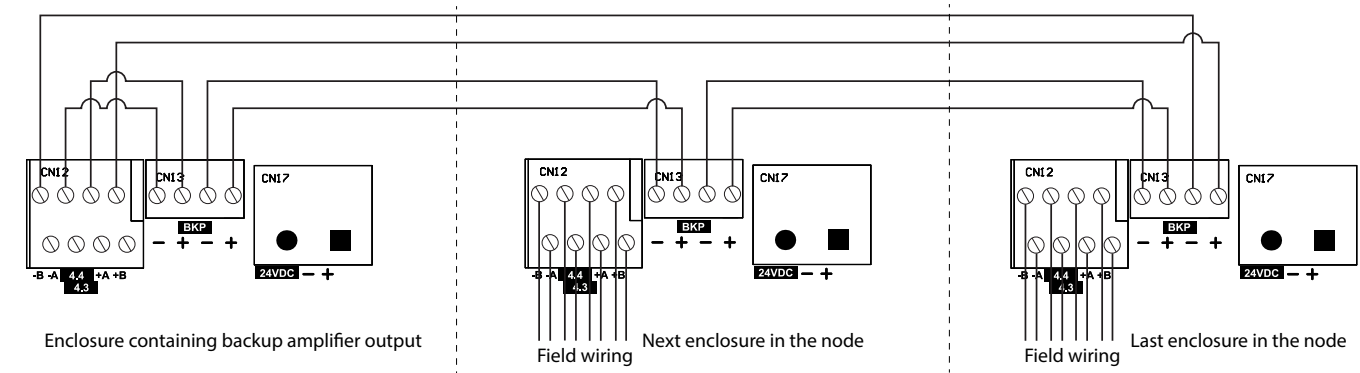

Figure 79 Backup Amplifier Class B Wiring

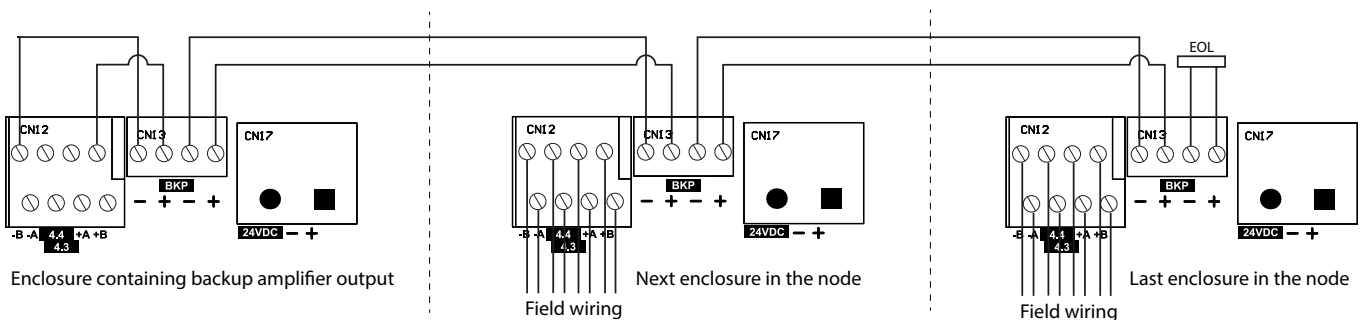

Table 24: Wiring Chart for 70V Speakers

Total Power	Maximum Wiring Run To Last Device (ELR)							
	18AWG		16AWG		14AWG		12AWG	
Watts	ft	m	ft	m	ft	m	ft	m
25	1740	531	2966	841	4399	1342	6995	2132
50	970	266	1383	421	2200	671	3497	1066
75	580	177	922	280	1466	447	2332	711
100	435	133	691	210	1100	335	1749	533



Notes for Wiring Charts: For each speaker zone, select the total zone power. Distance shown is calculated to the last speaker, based on the worst case with all speakers lumped at the end. Calculation is base on a 1dB power loss (20%) and a source of 70V or 25V.

Table 25 Wiring Chart for 25V Speakers

Total Power	Maximum Wiring Run To Last Device (ELR)							
	18AWG		16AWG		14AWG		12AWG	
Watts	ft	m	ft	m	ft	m	ft	m
25	218	66	346	105	550	168	875	267
50	109	33	173	53	275	84	437	133
75	73	22	115	35	183	56	292	89
100	54	17	86	26	138	42	219	67

Table 26 End of Line Resistor Value for Amplifier Circuits

Amplifier Type	Configuration	EOL	EOL Value
25V	25W	EOL-392	3.9 kΩ
	50W	EOL-202	2.0 kΩ
	75W	EOL-132	1.3 kΩ
	100W	EOL-102	1 kΩ
70V	25W	EOL-103	10 kΩ
	50W	EOL-512	5.1 kΩ
	75W	EOL-332	3.3 kΩ
	100W	EOL-252	2.5 kΩ

12.0 Indication

Figure 80 Audio Cabinet Displays and Controls

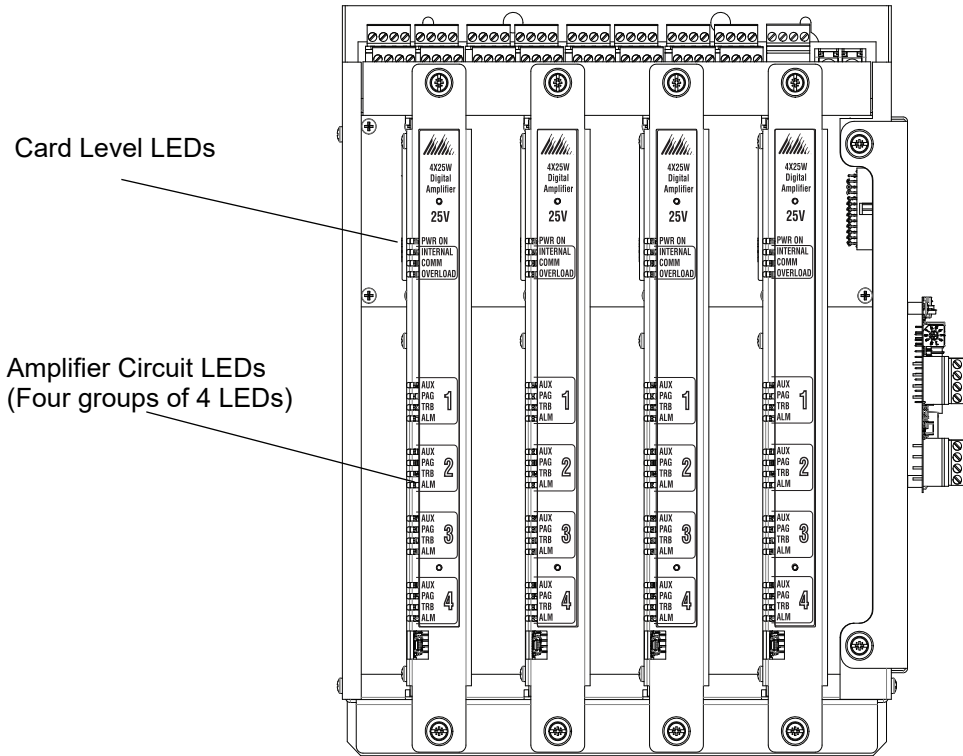

There are 20 LEDs provided on each amplifier. The top group of 4 LEDs are for each terminal block (Card Level LEDs) and the 16 LEDs below are four groups of 4 LEDs used for the amplifier circuits.

12.1 Amplifier Displays

FOUR CARD LEVEL LEDS

Power

Internal Trouble

Common Trouble

Overload - power overload indication

FOUR SETS OF FOUR LEDS FOR EACH CIRCUIT

Auxiliary - solid blue for BG (background music) - blinking blue for startup

Paging - solid green, active page

Trouble - solid amber for amplifier trouble

Alarm - solid red for alarm condition, flashing red for alert condition

13.0 Audio Configuration

The configuration of the FX-MNS-6000 is accomplished via the MGC Network computer based Configurator Software.

14.0 System Checkout

14.1 Before Turning the Power On

1. To prevent sparking, *do not* connect the batteries. Connect the batteries after powering the system from the main AC supply.
2. Check that all modules are installed in the proper location with the proper connections.
3. Check all field (external) wiring for opens, shorts, and ground.
4. Check that all interconnection cables are secure, and that all connectors are plugged in properly.
5. Check all jumpers and switches for proper setting.
6. Check the AC power wiring for proper connection.
7. Check that the chassis is connected to EARTH GROUND (cold water pipe). Refer to NFPA 70.
8. Make sure to *close the front cover plate* before powering the system from main AC supply.



Note: When using Class A and isolators on an addressable loop, configure system as Class B, wire loops Class A, except do not connect the last device back to the panel. Do a system checkout. Then connect the return of the Class A circuit and configure as Class A.

14.2 Power-Up Procedure

1. After completing the above procedures, power up the panel (AC only). The green AC On LED and the Common Trouble LED should illuminate, and the buzzer should sound.
2. Press the System Reset button. Since the batteries are not connected, the Battery Trouble LED should illuminate, the trouble buzzer should sound intermittently, and the Common Trouble LED should flash.
3. Connect the batteries while observing correct polarity: the red wire is positive (+) and the black wire is negative (-). All indicators should extinguish except for the AC On LED and the LCD should show a normal status condition.
4. Auto-Configure or PC Configure the fire alarm control panel as described in the Configurator Guide.

14.3 Troubleshooting

Table 27: Troubleshooting

Message	Description
Circuit Trouble	Normally when a circuit trouble occurs, its designated trouble indicator will be illuminated, as well as the Common Trouble indicator and Trouble buzzer. To correct the fault, check for open wiring on that particular circuit loop or see if the circuit disconnect switch is in the ON or CLOSED position. <i>Note: disconnecting a circuit will cause a system trouble (off-normal position).</i>
Ground Fault	The FleX-Net™ FX-4000 panel has a Common Ground Fault Detector. To correct the fault, check for any external wiring touching the chassis or other earth ground connection.
Battery Trouble	Check for the presence of batteries and their condition. Low voltage (below 20.4V) will cause a battery trouble. If battery trouble condition persists, replace the batteries as soon as possible.

15.0 Indicators, Controls, and Operation

Refer to figure below for LED indicators, control buttons, and switches locations.

Figure 81 Indicators and Control Location

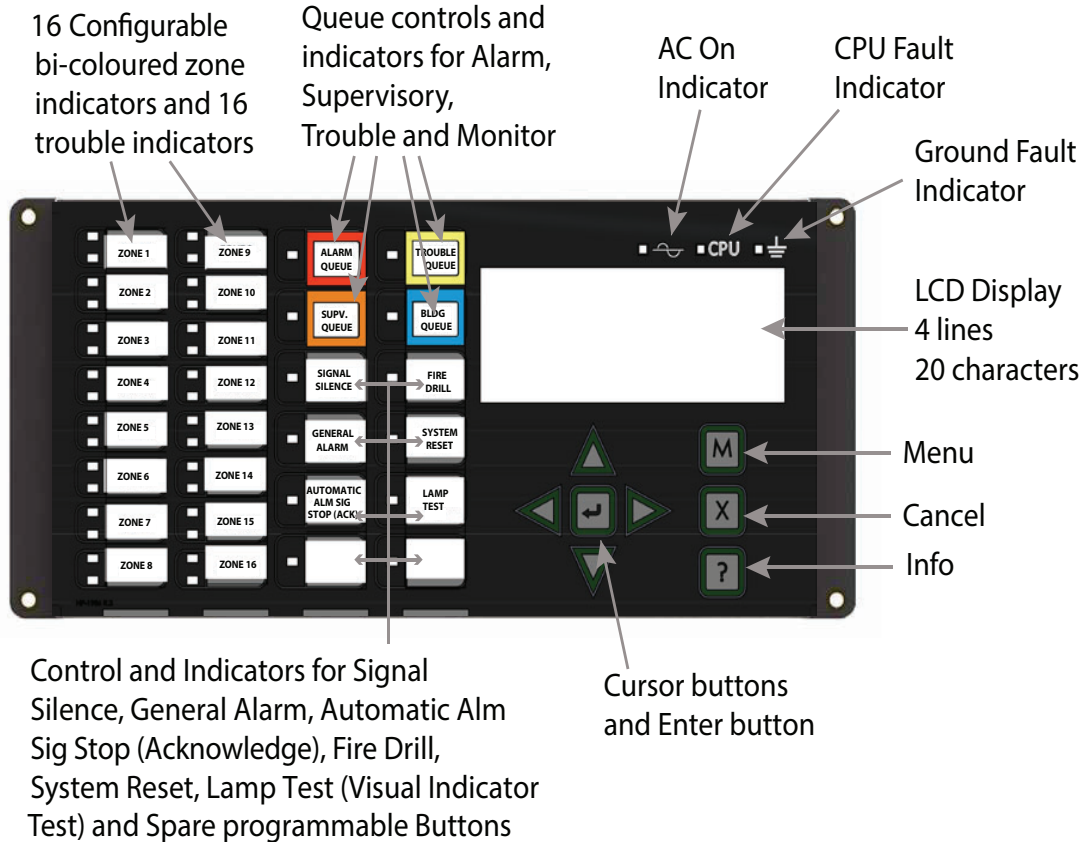

LED indicators are amber (trouble or supervisory), red (alarm), or green (AC On), and may illuminate continuously (steady) or at one of two flash rates:

- **Fast Flash:** 120 flashes per minute, 50% duty cycle.
- **Trouble Flash:** 20 flashes per minute, 50% duty cycle



Note: The General Alarm LED and pushbutton, and the Automatic Alm Sig Stop (Ack) LED and pushbutton, are active only on a system configured for “Two Stage.”

Paper Labels for Buttons and Indicators

Buttons and indicators are supplied with paper labels. These labels slide into the plastic label templates on the face of the panel. Paper labels allow for easy English / French selection and custom-printed zone information.

15.1 Common Indicators

Table 28: Common Indicators

Indicators	Description
Buzzer	<p>The Buzzer is activated by any of the following:</p> <ul style="list-style-type: none"> Fire Alarm - Steady Supervisory Alarm - Fast Rate Trouble - Trouble Rate Monitor - Configurable to sound at Trouble Rate <p>If the Buzzer is turned on in response to a Non-Latching Trouble or Supervisory, it will be turned off if the condition causing it goes away and there is no other reason for it to be on.</p>
AC On LED	The AC On Indicator is activated steady green while the main AC power is within acceptable levels. It is turned off when the level falls below the power-fail threshold and the panel is switched to standby (battery) power.
Alarm Queue LED	The Common Alarm LED flashes red whenever the Panel is in Alarm. An alarm results from any alarm on any point or input programmed as Alarm or activation of the manual red General Alarm Button (if the Panel is set for Two Stage Operation). The Alarm Queue LED will go steady, once all alarms in the queue have been reviewed using the Alarm Queue button. Since all Alarms are latched until the Panel is reset, the Common Alarm LED will remain on until then.
Supervisory Queue LED	The Common Supv. (Supervisory) LED flashes amber at the Fast Flash Rate when there is a Supervisory Alarm in the Panel, as the result of any Latching or Non-Latching Supervisory Circuit. The LED turns off if all Non-Latching Supervisory Circuits are restored and there are no Latching Supervisory Circuits active. The Supv. Queue LED will go steady, once all supervisory alarms in the supervisory queue have been reviewed using the Supv. Queue button. Latching Supervisory Alarms remain active until the Panel is reset.
Trouble Queue LED	The Common Trouble LED flashes amber at the Trouble Flash Rate when there is any Trouble condition being detected on the panel. It is turned off when all Non-Latching Troubles are cleared. The Trouble Queue LED will go steady, once all troubles in the trouble queue have been reviewed using the Trouble Queue button.
BLDG Queue LED	The BLDG Queue LED flashes amber at the Trouble Flash Rate when there is any monitored building condition being detected on the panel. It is turned off when all building monitors are cleared.
CPU Fault LED	The CPU Fault Indicator is flashed yellow at the Trouble Flash Rate if the CPU is faulty.
Fire Drill LED	The Fire Drill Indicator turns on steady amber while Fire Drill is active.
Automatic Alm Sig Stop (Ack) LED	If the Panel is configured as Two Stage, the Automatic Alm Sig Stop (Ack) Indicator flashes amber at the Fast Flash Rate while the Auto General Alarm Timer is timing out. It turns on steady amber when that Timer is cancelled by activating the Automatic Alm Sig Stop (Ack) or Signal Silence buttons. If the Auto General Alarm Timer times-out and puts the Panel into General Alarm, the Indicator is turned off.
General Alarm LED	In Two Stage Operation only, the General Alarm LED is steady red when general alarm is activated due to the red General Alarm button being pushed, a General Alarm Initiating Circuit being activated, or the Auto General Alarm Timer timing out. Once the General Alarm LED has been turned on it will stay active until the Panel is reset.
Signal Silence LED	The Signal Silence indicator is flashed amber, at the trouble rate when Indication Circuits are Silenced either by the Signal Silence button, or by the Auto Signal Silence Timer. It is turned off when the Signals are re-sounded by a subsequent Alarm.
Ground Fault LED	The Ground Fault Indicator flashes amber at the Trouble Rate when the Ground Fault Detector detects a Ground Fault on any field wiring. It turns off immediately when the Ground Fault is cleared.





15.2 Common Controls





15.2.1 LCD Display





The display is a large 4 line by 20 character back-lit alphanumeric LCD. It displays information on the panel and its devices. There are cursor buttons for menu selection and control. Information provided by the LCD display is an alarm log, an event log, current levels, device information, verification and maintenance reports.





15.2.2 Queue Buttons

Use the queue buttons to select a particular queue to review.

Press the **Alarm Queue** button to cycle through all the unacknowledged alarms. Press the Up  and Down  buttons to cycle through all the alarms, both acknowledged and unacknowledged. Press the right cursor button  to scroll up by 10 events at a time. Press the left cursor button  to scroll down by 10 events at a time.

Press the **Supervisory Queue** button to cycle through all the unacknowledged supervisory conditions. Press the Up  and Down  buttons to cycle through all supervisory conditions, both acknowledged and unacknowledged. Press the right cursor button  to scroll up by 10 events at a time. Press the left cursor button  to scroll down by 10 events at a time.

Press the **Trouble Queue** button to cycle through all the unacknowledged trouble conditions. Press the Up  and Down  buttons to cycle through all troubles, both acknowledged and unacknowledged. Press the right cursor button  to scroll up by 10 events at a time. Press the left cursor button  to scroll down by 10 events at a time.

Press the **Building Queue Button** to cycle through all the unacknowledged building (monitor) conditions. Press the Up  and Down  buttons to cycle through all queued monitor conditions, both acknowledged and unacknowledged. Press the right cursor button  to scroll up by 10 events at a time. Press the left cursor button  to scroll down by 10 events at a time.

Queues are displayed on the screen according to a priority sequence. Queue priority ranking from highest to lowest is as follows: alarm, supervisory, trouble, and monitor. If, for example, you are viewing a monitor queue and an alarm occurs, the display will immediately display the alarm condition. Also, if there is no activity on the system for 10 seconds after you have pressed a queue button, the display will switch to the highest priority condition.

15.2.3 Cursor Buttons

These four buttons around the Enter Button are used for up (previous), down (latest), left, and right selection of items on the LCD Display.

15.2.4 Enter Button

This button is used to select a displayed item on the LCD Display.

15.2.5 Cancel Button

This button is used to cancel an operation.

15.2.6 Menu Button

This button is used to initiate the FleX-Net™ FX-4000 Menu System.

15.2.7 Info Button

This button is used to get more details about a displayed item.

15.2.8 System Reset Button

The System Reset button causes the Fire Alarm Control Panel, and all Circuits, to be reset

- Resets all Latching, Trouble Conditions
- Resets all Initiating Circuits
- Resets 4-Wire Smoke Supply and Aux. Power Supply
- Turns off all NACs
- Turns off Signal Silence, Ack & GA Indicators
- Turns off Fire Drill
- Stops and resets all Timers
- Processes inputs as new events
- Aux Disconnect is not affected
- Reset cannot be activated until the Signal Silence Inhibit timer has expired.

15.2.9 Signal Silence Button

Activation of the Signal Silence button when the Panel is in Alarm, turns on the Signal Silence Indicator and deactivates any Silenceable NACs. Non-Silenceable Circuits are unaffected. Pressing the Signal Silence button again reactivates the NACs and extinguishes the Signal Silence Indicator. Signals will re-sound upon any subsequent Alarm. This button does not function during any configured Signal Silence Inhibit Timer period. It also does not function if the NACs are active as the result of a Fire Drill. In a Two Stage System, if the Auto General Alarm Timer has timed out, this Signal Silence button also performs the same function as the Automatic Alm Sig Stop (Ack) button.

15.2.10 Fire Drill Button

The Fire Drill button activates all programmed and non-Disconnected NACs, but does not transmit any Alarms via the City Tie, or Common Alarm Relay. Fire Drill may be programmed to operate specific NACs. Fire Drill is cancelled by pressing the button again (toggle switch), or if the Panel goes into a real Alarm.

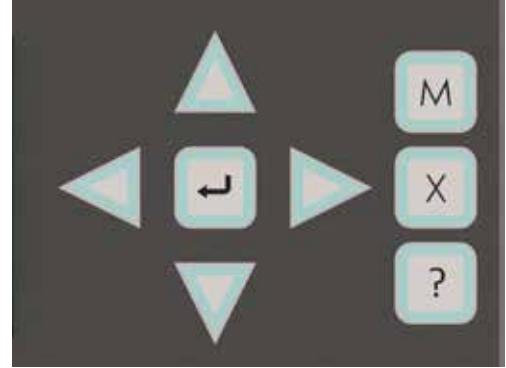

15.2.11 Automatic Alm Sig Stop (Ack) Button (Two Stage Only)

If the Panel is not configured for Two Stage Operation, this button does nothing. If the Panel is configured for Two Stage Operation, activation of the Automatic Alm Sig Stop (Ack) button while the Auto General Alarm Timer is timing (there is an Alarm in the Panel, but it is still in the First Stage), that timer is cancelled, and the Automatic Alm Sig Stop (Ack) Indicator is on steady amber.

15.2.12 General Alarm Button

Activation of the General Alarm button immediately sends the Panel into General Alarm. It will also re-activate the Signals if they have been Silenced during General Alarm. The General Alarm condition remains active until the Panel is reset.

15.2.13 Lamp Test Button

Activation of the Lamp Test button turns all front panel Indicators on steady in whichever colour they would normally be activated and turns the buzzer on steady. If Lamp Test is active for more than 10 seconds, Common Trouble is activated.

15.2.14 Emergency Voice Control

Request control, press button, Deny control by timeout, Grant press button to transfer control.

Each Node will have an assigned request control and grant button and LED (one button/LED per Node) to transfer emergency voice control. All Node Request/Grant button and LEDs will be available at all Nodes. For example if there are 3 Nodes, each Node will have 3 Request/Grant buttons and LEDs representing all the Nodes 1 to 3.

To gain immediate emergency voice control, press the Node Request/Grant button, LED will illuminate steady and voice control will be available at that physical Node.

Request Control - press the Request/Grant button at the Node that will be used to provide emergency voice. The associated Request/Grant button LED will flash at the Node which has control.

Grant Control - press the Request/Grant button of the requesting Node (flashing LED) to grant control.

If a Node has emergency voice control the LED will be ON steady.

Deny is achieved through a timeout, which is configurable.

15.3 Single Stage Operation

In a single stage system, all alarm inputs are treated in a similar manner. Alarm inputs include any of the following: non-verified alarm, verified alarm, sprinkler alarm, water-flow alarm, and general alarm circuits. Any of these alarm inputs occurring when the panel is not already in alarm cause the following:

- The buzzer sounds steadily
- If fire drill is active, it is cancelled
- The Common Alarm LED turns on
- The Common Alarm relay activates if Aux disconnect is not active
- The Auto Signal Silence timer, if configured, starts
- The Signal Silence Inhibit timer, if configured, starts
- All non-disconnected NACs programmed to the input are activated provided that Aux disconnect is not active
- Non-disconnected strobes associated with the input are activated
- Non-disconnected signals associated with the input are activated at the evacuation rate

Subsequent alarms when the panel is already in alarm, cause the following:

- The alert buzzer sounds steadily
- If Signals have been silenced, they are resounded, the Signal Silence LED turns off, and the Auto Signal Silence timer, if configured, is restarted
- Any additional non-disconnected strobes associated with the input are activated continuously
- Any additional non-disconnected signals associated with the new input are activated at the evacuation rate

15.4 Two Stage Operation

In a two stage system, alarm inputs are either first stage (alert) inputs or second stage (general alarm) inputs. First stage inputs include inputs from the following types of circuits: non-verified alarm, verified alarm, sprinkler alarm, and water-flow alarm. Second stage inputs include alarms on the general alarm circuits, activation of the General Alarm button, or expiration of the Auto General Alarm timer. Any of these alarm inputs occurring when the panel is not already in alarm cause the following:

- The buzzer sounds steadily.
- If fire drill is active, it is cancelled.
- The Common Alarm LED turns on.
- The Common Alarm relay activates if Aux disconnect is not active.
- The Auto Signal Silence timer, if configured, starts.
- The Signal Silence Inhibit timer, if configured, starts.
- All Non-disconnected indicating programmed to the input are activated provided that Aux disconnect is not active.

If the alarm is a second stage alarm:

- All non-disconnected strobe circuits are activated continuously.

- All non-disconnected signal circuits are activated at the evacuation rate.
- The General Alarm LED turns on.

If the alarm is a First Stage alarm:

- Non-disconnected strobe circuits programmed to that circuit are activated continuously.
- Non-disconnected signal circuits programmed to that circuit are activated with the alert code.
- The Auto General Alarm timer, if configured, starts.
- The Automatic Alm Sig Stop (Ack) LED starts flashing.

Subsequent First Stage alarms when the panel is already in alarm, cause the following:

- The buzzer sounds steadily.
- If signals have been silenced as a result of the silence button or the Auto signal silence timer, signals are resounded as they were before signal silence, the Signal Silence LED turns off, and the Auto Signal Silence timer, if configured, is restarted.
- If the panel is not already in General Alarm, additional non-disconnected signals programmed to the new input are activated with the Alert Code (see section 15.6.2).
- If the panel is not already in General Alarm and if the Automatic Alm Sig Stop (Ack) LED is on steady indicating that the Auto General Alarm timer has been Acknowledged the timer is restarted and the Automatic Alm Sig Stop (Ack) LED is extinguished.

A second stage alarm (general alarm) when the panel is already in alarm causes the following:

- The buzzer sounds steadily.
- All non-disconnected signals are activated at the evacuation rate.
- If the Signal Silence LED is on, it turns off and the Auto Signal Silence timer, if configured, is restarted.
- The Automatic Alm Sig Stop (Ack) LED if on, turns off.

Alarm inputs are latching: they remain active until system reset.



Note: If the system is configured for correlations, any second stage / general alarm condition activates all NACs whether they are correlated or not.

15.5 Pre-Signal Operation

To configure the panel for pre-signal, all alarm inputs must be correlated to one NAC circuit that is wired to a Notification Appliance in the Control Room that is constantly monitored by an Operator. Using the FleX-Net™ FX-4000 Configurator, “Subsequent Alarm” in “Common System Status” must be correlated to turn on the Remaining NAC circuits in the system. To confirm the alarm (i.e. subsequent alarm) the operator can press the “General Alarm” button on the panel or activate a Manual Station in the Control Room.



Note: Pre-Signal is not permitted to be used in Canada, unless approved by the AHJ.

15.6 Circuit Types

The term **circuits** refers to an actual electrical interface, either initiating (detection) or indicating (signal). The term **zone** is a logical concept for a fire alarm protected area, and will consist of at least one circuit. Often the terms zone and circuit are used interchangeably, but in this manual the term circuit is used.

15.6.1 Initiating (Detection) Circuit Type

Table 29: Initiating (Detection) Circuit Types

Initiating (Detection) Circuit Type	Description
Non-Verified Alarm	This is a "normal" type of alarm which may have pull stations, smoke detectors, or heat detectors attached. Any activation of these devices will immediately result in an alarm condition in the fire alarm control panel. An alarm condition causes the associated circuit Status LED and the Common Alarm LED to illuminate red.
Verified Alarm	These alarms are verified by a reset and timing procedure, and may have Manual Stations, smoke detectors attached. Any activation of Manual Stations will result in an alarm condition in the fire alarm control panel within four seconds. Smoke detectors will be verified for a real alarm within 60 seconds depending upon the start-up time of the smoke detectors being used. If four seconds is too long a response time for pull stations, then they should be wired separately on a non-verified alarm circuit. An alarm condition causes the associated circuit Status LED and the Common Alarm LED to illuminate red. Verified Alarm is not permitted for heat detectors, 4-wire smoke detectors and smoke detectors with built-in alarm verification. Refer to Appendix D for details.
Water-Flow Alarm	An alarm for water-flow sensors. These alarms are identical to normal non-verified alarms except that any NACs programmed to these circuits (all are by default) are non-silenceable. Also, if water-flow retard operation is enabled, then these circuits are sampled every one second; if ten samples are active within any 15 second interval, the water-flow alarm is confirmed and processed. An alarm condition causes the associated circuit Status LED and the Common Alarm LED to illuminate red. Note: Do not use the retard operation with any external retarding device; maximum retard may not exceed 120 seconds.

Table 29: Initiating (Detection) Circuit Types (Continued)

Initiating (Detection) Circuit Type	Description
Sprinkler Alarm	<p>An alarm for sprinkler flow sensors. These alarms are identical to normal non-verified alarms unless the water-flow retard operation is enabled. If water-flow retard operation is enabled, then these circuits are sampled every one second; if ten samples are active within any 15 second interval, the sprinkler alarm is confirmed and processed. An alarm condition causes the associated circuit Status LED and the Common Alarm LED to illuminate red.</p> <p>Note: Do not use the retard operation with any external retarding device; maximum retard may not exceed 120 seconds.</p>
General Alarm	<p>These alarms provide remote general alarm such as for remote key switches. In a two stage system, these inputs perform exactly the same function as the front panel or remote annunciator General Alarm button. In a single stage system, these inputs act the same as non-verified alarms, but if correlations are enabled, general alarm initiating circuits are correlated to <i>all</i> NACs.</p>
Non-Latching Supervisory	<p>These alarms are for supervisory devices. An activation on these circuits will cause the Circuit Status LED and the Common Supervisory LED to illuminate amber. The buzzer will sound continuously. If the circuit activation is removed, the supervisory condition will clear (so long as there are no other supervisory conditions in the system) and the circuit Status LED will extinguish.</p>
Latching Supervisory	<p>These alarms are for supervisory devices. An activation on these circuits will cause the Circuit Status LED and the Common Supervisory LED to illuminate amber. The buzzer will sound continuously. If the circuit activation is removed, the Supervisory condition will <i>not</i> clear.</p>
Monitor (BLDG)	<p>This is a supervised general purpose non-latching input used mainly for correlating to a relay circuit. No other system condition occurs as a result of its activation (short-circuit), although it is supervised for trouble (open-circuit).</p>
Trouble-Only	<p>This circuit is used for monitoring a trouble condition from an external device such as a Mircom Series 500 Audio System. Both open and short circuits generate a non-latching trouble condition.</p>

15.6.2 Indicating (Signal) Circuit Types

Table 30: Initiating (Signal) Circuit Types

Indicating (Signal) Circuit Type	Description
Silenceable Signal	<p>For audible devices such as bells and piezo mini-horns that may be silenced either manually or automatically. While sounding, these follow the pattern appropriate for the condition: the configured evacuation code (default is temporal code) during single-stage alarm, or two stage general alarm, or the alert code during a two stage system's alert (first) stage.</p>
Non-Silenceable Signal	<p>For audible devices such as bells and piezo mini-horns that may not be silenced either manually or automatically. While sounding, these follow the pattern appropriate for the condition: the configured evacuation code (default is temporal code) during single-stage alarm, or two-stage general alarm, or the alert code during a two stage system's alert (first) stage.</p>
Coded Signal	<p>For audible devices such as bells and piezo mini-horns that may be activated in code. The code consists of 4 digits with each digit consisting of 1-15 pulses on the signals. Each coded circuit can sound the complete code 1 to 15 times after which signals go silent or revert to programmed General Alarm rate.</p> <p>Note: The NFPA-72 and ULC-S527 specify temporal tone. However, for retrofits of systems that were previously approved, coded signalling is allowed.</p>
Strobe	<p>For visual devices such as strobes that use no code patterns (they are continuous).</p>

15.6.3 Evacuation Codes

Single stage codes

Continuous	On 100% of the time
Temporal Code	3 of 0.5 second on, 0.5 second off then, 1.5 second pause
March Code	0.5 second on, 0.5 second off
California Code	5 seconds on, 10 seconds off

Two-stage codes

Alert Code	0.5 second on, 2.5 seconds off
General Alarm	Evacuation code as selected from above.

Figure 82 Evacuation Codes

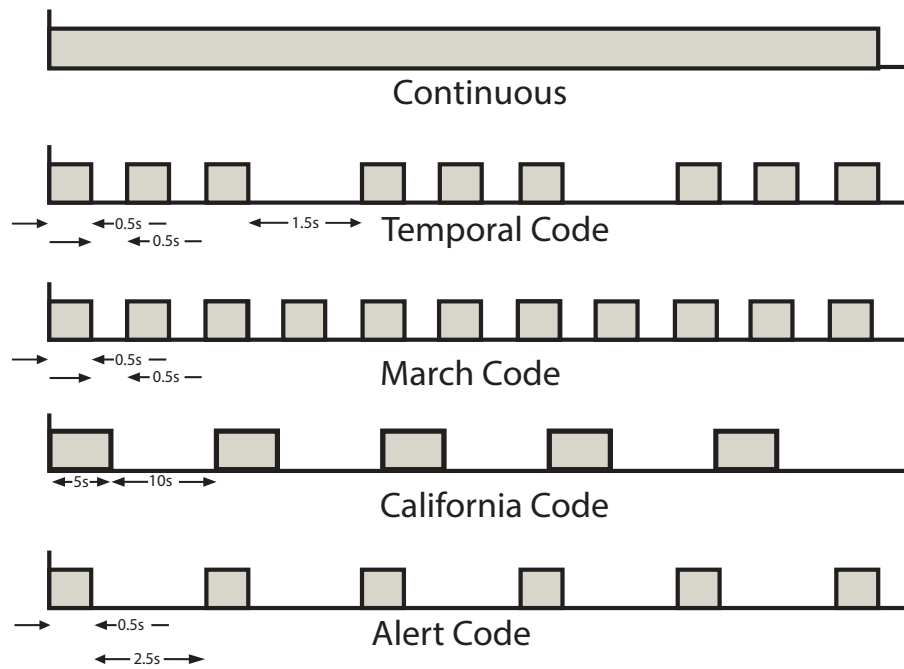

16.0 Configuration

Table 31: Settings Permitted in CAN/ULC-S527 and CAN/ULC-S559

NOTICE TO USERS, INSTALLERS, AUTHORITIES HAVING JURISDICTION, AND OTHER INVOLVED PARTIES			
This product incorporates field-programmable software. In order for the product to comply with the requirements in CAN/ULC S527 Standard for Control Units for Fire Alarm Systems and CAN/ULC-S559 Standard for Equipment for Fire Signal Receiving Centers and Systems certain programming features or options must be limited to specific values or not used at all as indicated below.			
Program feature or option	Permitted in CAN/ULC-S527, S559? (Y/N)	Possible settings	Settings permitted in CAN/ULC-S527, S559
MP Addressable manual station or monitor module configured as a manual station	Y	Addresses 1-240	Addresses 1-192

The FX-MNS-6000 network system is configured using MGC software MSW-036.

NOTE: When setting up a system to use the Request, Grant, Deny functionality, if any nodes within that system have annunciators attached, the controls must be disabled on those annunciators.

16.1 Configuration Backup, Query and Fast-Forward

The panel supports previous, current and next configuration. The panel can be load configured without taking the panel off-line. Configuration reverts back to previous or moves to future configuration through front-panel menu.

16.2 Open Graphic Navigator Software Package

This software package (OpenGN) allows 3D graphic display of premises and devices. It provides unlimited floor plans and events, node and job support. It supports input file formats for floors such as: .svg, .dxf, .pdf, .png, .wmf, .jpeg. Device icons and state animations can be customized.

16.3 Ethernet Port

Integrated TCP/IP Stack, Hardware based MAC address. Provides a fully configurable IP address. Use this Ethernet port to connect to OPEN graphics software. This port also provides web server for diagnostic and system report via LAN or WAN connection on-site or remotely.

16.4 Boolean Logic Engine

Boolean logic functions are now available within the configuration software. Sophisticated logic functions such as: AND, OR, NOT, ANY n of m, >, <, >=, <>

Built-in timers or user configurable timers and intervals and schedules available to support UUKL operations.

16.5 Multiple Configuration file support

This program (inherent in the configuration) provides leading technology that allows a choice of multiple configuration files to support site-specific requirements.

Appendix A: Specifications

Fire Alarm Specifications

Table 32: Specifications

Main Fire Alarm Chassis FX-6000MNS-CH	Quad Intelligent Analog Loop Module ALCN-960MISO/ALCN-960D
<p>General</p> <p><i>Power limited:</i> 22 VDC, 400 mA max, max loop resistance 40 Ω</p> <p>4 Class B or A Indicating Circuits; configurable as strobes or audibles. Terminals are labelled "IND".</p> <p><i>Power limited:</i> 24 VDC unfiltered, 1.7 A @ 49°C per circuit</p> <p>Displays (incl LCD) and Controls for all Common Functions, and 16 Zone Displays.</p> <p>Optional PR-300 City Tie Module.</p> <p>Aux. Power Supply (for Remote Annunciators). Terminals are labelled "AUX PWR".</p> <p><i>Power limited:</i> 24 VDC unfiltered, 1.7 A @ 49°C</p> <p>Resettable 4-Wire Smoke Supplies. Terminals are labelled "4-WIRE".</p> <p><i>Power limited:</i> 22 VDC, 425 mA max., 5mV ripple</p> <p>One RS-485 Connection for Remote Annunciators or interface to Audio Systems. Terminals are labelled "RS485".</p> <p><i>Power Limited</i> to 300 mA.</p> <p>Auxiliary relays: (resistive loads)</p> <p>Must be connected to a Listed Power Limited Source of Supply. Terminals are labelled "ALARM, TROUBLE, SUPV".</p> <p>Common Alarm: Form C, 1 amp, 24 VDC Common Supv: Form C, 1 amp, 24 VDC Common Trouble: Form C, 1 amp, 24 VDC</p> <p>Micro-controller based design. Fully Configurable with PC software. Full walk test function.</p> <p>Ground Impedance 3.3 kΩ</p> <p>Open Circuit Fault 100 kΩ or more</p> <p>Short Circuit Fault 0.1 Ω or less</p> <p><i>For Indicating Circuits:</i> 24VDC, 1.7A per circuit 10 amps max total shared between main board NACs and SGM-1004A/SGM-1004S NACs</p> <p>FX-6000MNS-CH Main Board: <i>Current Consumption:</i> standby: 357 mA alarm: 506 mA</p>	<p>Quad Analog Loops with additional ALCN-960D daughter board capable of monitoring 960 MGC Sensors and Modules.</p> <p><i>Power limited:</i> 24 VDC, 400 mA max, 10kHz frequency max loop resistance 40 Ω</p> <p><i>Current Consumption:</i> standby: 200 mA alarm: 230 mA</p>
	<p>Quad Intelligent Analog Loop Module ALCN-4792MISO/ALCN-792D</p> <p>Quad Analog Loops with additional ALCN-792D daughter board capable of monitoring 636 AP Sensors and 636 AP Modules.</p> <p><i>Power limited:</i> 24 VDC, 400 mA max, 10kHz frequency max loop resistance 40 Ω</p> <p><i>Current Consumption:</i> standby: 130 mA alarm: 145 mA</p>
	<p>Detection Adder Module DM-1008A</p> <p>Eight supervised Class B initiating circuits; fully configurable. Terminals are labelled "INI". Initiating circuits are Compatibility ID "A".</p> <p><i>Current Consumption:</i> standby: 80 mA alarm: 1 zone active: 125 mA 2 zone active: 170 mA 4 zone active: 275 mA 6 zone active: 370 mA 8 zone active: 465 mA</p>
	<p>Signal Adder Module SGM-1004A</p> <p>Four Class B or A indicating circuits; configurable as strobes or audibles. Terminals are labelled "IND".</p> <p><i>Power Limited:</i> 24 VDC unfiltered max. 1.5 amps @ 49C per circuit</p> <p><i>Current Consumption:</i> standby: 60 mA alarm: 258 mA</p>
	<p>Signal Adder Module SGM-1004S</p> <p>Four Class B or A indicating circuits; configurable as strobes or audibles. Terminals are labelled "NAC".</p> <p>Special application for connecting FHS-400/FH-400/FS-400 series notification appliances to FX-6000MNS-CH. See compatibility document LT-1023 for more information:</p> <p>Max. voltage 33V DC max. 2.1 A @49 °C per NAC circuit max. 5 A per SGM-1004S</p> <p><i>Current Consumption:</i> standby: 31 mA alarm: 96 mA</p>
Fiber Optic Module FOM-2000-UM	Relay Adder Module RM-1008A (resistive loads)
<p><i>Current Consumption:</i> standby: 16mA (single mode) or 42mA (multi-mode) alarm: 6mA (single mode) or 42mA (multi-mode)</p>	<p>Must be connected to a listed power limited source of supply. Terminals are labelled "RLY".</p> <p>Eight fully configurable Form C indicating. Form C, 1 amp., 28 VDC (resistive loads)</p> <p><i>Current Consumption:</i> standby: 25 mA alarm: 150 mA</p>

Table 32: Specifications (Continued)

Audio Controller Module ANC-6000	Polarity Reversal and City Tie Module PR-300
<p><i>Current Consumption:</i> standby: 82 mA alarm: 87 mA</p>	<p>Supervised city tie--not power limited 24VDC unfiltered, 210 mA max., Trip coil: 14 Ω. Terminals are labelled "City Tie". Polarity reversal power limited Terminals are labelled "Polarity Reversal". 24VDC open 12VDC @ 3.5 mA, 8 mA max. (shorted) <i>Current Consumption:</i> standby: 35 mA alarm: 300 mA</p>
Telephone Controller Module TNC-5000	Network Controller Module FNC-2000
<p><i>Current Consumption:</i> standby: 195 mA alarm: 215 mA</p>	<p><i>Current Consumption:</i> standby: 190 mA alarm: 190 mA</p>
DSPL-420DS and DSPL-2440DS Displays	RAXN-4000LCDG Annunciator
<p><i>Current Consumption:</i> standby: 25mA and 30mA alarm: 30mA and 35mA</p>	<p>24V DC nominal. Standby: 139 mA Max., All LEDs On: 164 mA Max.</p>
Fan Damper Display Module FDX-008W(KI)	RAXN-4000LCDGC Annunciator
<p>24V DC nominal, range of 20 to 39V DC. <i>Current Consumption:</i> standby: 15mA Max. alarm (all LEDs On): 35mA Max.</p>	<p>24V DC nominal. Standby: 225 mA Max., All LEDs On: 235 mA Max.</p>
Digital Communicator Module UDACT-300A	RAXN-4000LCD Annunciator
<p>Transmit alarm, supervisory, and trouble to a central monitoring station. <i>Current Consumption:</i> standby: 45 mA alarm: 120 mA</p>	<p>24V DC nominal, range of 20 to 39V DC. Standby: 139 mA Max., All LEDs On: 164 mA Max.</p>
Programmable Input Switches Module IPS-4848DS	Programmable Input Switches Module IPS-2424DS
<p><i>Current Consumption:</i> standby: 10 mA alarm (one zone active): 22 mA</p>	<p><i>Current Consumption:</i> standby: 5 mA alarm (one zone active): 22 mA</p>
Adder Annunciator Module RAX-1048TZDS	
<p>48 Display Points <i>Current Consumption:</i> standby: 139 mA alarm: 1 zone LED active: 26 mA 2 zone LEDs active: 30 mA 3 zone LEDs active: 35 mA 4 zone LEDs active: 39 mA 48 zone LEDs active: 262 mA</p>	
Compliance	
<p>System Model: FX-6000MNS-CH System Type: Local, auxiliary (using PR-300), remote protected premise station (using PR-300 or UDACT-300A), central station protected premises (using UDACT-300A). Proprietary System (PPU) and Smoke Control Type of Service: A, M, WF, SS (with PR-300 or UDACT-300A), PPU Type of Signalling: Non-coded Applicable Standards: NFPA 70 and 72, UL-864 R10, ULC S-524, ULC S527</p>	

FX-MNS-6000 Audio Specifications



Note: All circuits are power limited, unless specified otherwise.

Table 33: FX-MNS-6000 Audio Specifications

QPS-6650 Power Supply and Charger	FNC-2000 Fire Network Controller Module
0 to 49 degrees Celsius, 0 to 93 + or - 2% RH (non-condensing) operating range Power input: 120 VAC, 60Hz / 230 VAC, 50Hz Power supply ratings: 120VAC, 6.1A, 732 watts 230VAC, 3.13A, 720 watts Primary input is non-power limited Battery: 24VDC, Gel-Cell/Sealed Lead-Acid Charging for up to 80 Ah batteries	Current consumption: <i>standby:</i> 190mA <i>alarm:</i> 190mA
ANC-6000 Audio Network Controller Module	TNC-5000 Telephone Network Controller Module
Current consumption: <i>standby:</i> 82 mA <i>alarm:</i> 87 mA	Current consumption: <i>standby:</i> 195mA <i>alarm:</i> 215mA
QCC-6000 Communication Card	FOM-2000-UM Fiber Optics Module
Current consumption: <i>standby:</i> 71.4mA <i>alarm:</i> 77mA	Current consumption: <i>standby:</i> 16mA (single mode) or 42mA (multi-mode) <i>alarm:</i> 16mA (single mode) or 42mA (multi-mode)
QAD-6425-25/QAD-6425-70 Amplifier with 100 Watts	QMP-6101N(V) Paging Microphone
70V or 25V constant voltage output One to four, fully supervised Class "A" or "B" speaker zones 100 watts maximum per amplifier Freq. Response: UL bandwidth from 800 to 2800 Hz ULC bandwidth from 400 to 4000 Hz Harmonic distortion less than 2.5% at 1 KHz Current consumption: 25V Model <i>standby:</i> 314mA, <i>alarm:</i> 5.62A 70V Model <i>standby:</i> 270mA, <i>alarm:</i> 5.97A	QMP-6101NV mounts in BBX-FXMNS-6000 enclosure QMP-6101N mounts in BB-5008 and BB-5014 enclosures Current Consumption: <i>standby:</i> 20.5mA <i>alarm:</i> 20.5mA
QAZT-5348DS Paging or Telephone Selector Panel	QMT-5302NV Master Telephone
Mounts in a BBX-FXMNS-6000 enclosure Connects to QMP-6101N(V) to provide 48 zones of paging control Up to one per QMP-6101N(V) Current Consumption: <i>standby:</i> 10mA <i>alarm:</i> 22mA	Mounts in a BBX-FXMNS-6000 enclosure Current Consumption: <i>standby:</i> 1mA <i>alarm:</i> 13mA

Appendix B: Power Supply and Battery Calculations

Power Requirements (All currents are in amperes)							
Model Number	Description	Qty		Standby	Total Standby	Alarm	Total Alarm
FX-6000MNS-CH	Main Chassis (12 amp)		X	0.357	=	0.506	=
ALCN-960MISO and ALCN-960D	Quad Analog Loops		X	0.200	=	0.230	=
ALCN-4792MISO and ALCN-792D	Quad Analog Loops		X	0.130	=	0.145	=
FNC-2000	Fire Network Controller Module		X	0.190	=	0.190	=
ANC-6000	Audio Network Controller Module		X	0.082	=	0.087	=
TNC-5000	Telephone Network Controller Module		X	0.195	=	0.215	=
FOM-2000-UM	Fiber Optics Module - single		X	0.016	=	0.016	=
FOM-2000-UM	Fiber Optics Module - multi		X	0.042	=	0.042	=
QMP-6101N(V)	Vertical Master Paging Module		X	0.0205	=	0.0205	=
QCC-6000	Communication Card		X	0.0714	=	0.077	=
QAD-6425-70	100W Amplifier		X	0.270	=	5.97	=
QAD-6425-25	100W Amplifier		X	0.314	=	5.62	=
DM-1008A	8 Initiating Circuit Module		X	0.080	=	1 zone active: 0.125 2 zone active: 0.170 4 zone active: 0.275 6 zone active: 0.370 8 zone active: 0.465	=
SGM-1004A	4 Indicating Circuit Module		X	0.060	=	0.258	=
SGM-1004S	4 Indicating Circuit Module		X	0.031	=	0.096	=
RM-1008A	8 Relay Circuit Module		X	0.025	=	0.150	=
FDX-008W(KI)	Fan Damper Control Module		X	0.015	=	0.035	=
DSPL-420DS	Narrow Display		X	0.025	=	0.025	=
DSPL-2440DS	Graphic Display		X	0.029	=	0.035	=
UDACT-300A	Dialer Module		X	0.045	=	0.120	=
PR-300	City Tie Module		X	0.035	=	0.300	=
RAX-1048TZDS	Adder Annunciator Chassis		X	0.022	=	1 zone active: 0.026 2 zone active: 0.030 3 zone active: 0.035 4 zone active: 0.039 48 zone active: 0.262	=
RAM-1032TZDS	Adder Annunciator Chassis		X	0.050	=	32 zone active: 0.300	=
AGD-048	Adder Graphic Driver Board		X	0.035	=	__(#of LEDs) x 4mA (Refer to LT-847 if using lamps)	=
IPS-4848DS/ IPS-2424DS	Programmable Input Switches Module		X	0.010/0.005	=	0.022/0.022	=
Two-Wire Smoke Detectors			X	♦ 0.00005	=	*0.39	= 0.39
MIX-1251B/BA Analog Ion Smoke Detector			X	0.0003	=	0.0065	=
MIX-2251B/BA Analog Photo Smoke Detector			X	0.0003	=	0.0065	=
MIX-2251TMB/TMBA Analog Thermal Sensor			X	0.0003	=	0.0065	=
MIX-M500MB/MA, MIX-M501MB/MA Monitor			X	0.0004	=	0.0051/0.0055	=
MIX-M500R(A)/MIX-M500S(A) Addressable Control Module			X	0.0003	=	0.0051	=

MIX-M500X(A) Fault Isolator Module		X	0.00045	=	450µA	=
B224BI(A) Analog Base with Isolator		X	0.00045	=	0.005	=
Four-Wire Smoke Detectors		X		=		=
Signal Load (bells, horns, strobes, and etc.)		X		=		=
Auxiliary Power Supply for Remote Annunciators				=	Alarm	=
Total currents (Add above currents)				STANDBY (A)		(B)

Legend: * Assuming three initiating circuits in alarm.

♦ Using the **2W-B or C2W-BA** 2-wire smoke detector. See LT-1023 Compatibility List for other compatible smoke detectors.

To Calculate Battery Size:

Add all the alarm currents in column (B), and use this value to determine the battery capacity requirement.

Total Current Requirement: ALARM (total from column B) _____ amps.

Use the total from column (A) as the standby current required. Multiple this value by 24 hours or 60 hours depending on AHJ. Add this total to the total of column (B) multiplied by the time in hours to sustain alarm.

* Use **0.084** for five minutes of alarm or **0.5** for thirty minutes of alarm as a multiplier figure.

Battery Capacity Requirement:

$$([\text{STANDBY (A) } ______] \times [(24 \text{ or } 60 \text{ Hours) } ______] + ([\text{ALARM (B) } ______] \times [\text{*Alarm in Hr.}] ______)) = (\text{C}) ______ \text{Ah}$$

Battery Selection: Multiply (total from column C) by 1.25 to derate battery.

Batteries: BA-12V55 (55Ah) will fit in the BBX-FXMNS-6000 and QBB-6001. Batteries larger than 55Ah will fit into a BC-160(R) Battery Cabinet.

RAXN-4000LCD/RAXN-4000LCDG/RAXN-4000LCDGC

The RAXN-4000LCD Remote Shared Display is a remote annunciator that provides the same functions as the main display on the fire alarm control panel, less 16 zone LEDs. The RAXN-4000LCDG is similar to the RAXN-4000LCD except its display is a graphical LCD. It is equipped with expanded memory of more than 18,000 system points, large 4 line x 20 character backlit alphanumeric LCD display (or for the RAXN-4000LCDG and RAXN-4000LCDGC a graphical display) which uses a simple menu system complete with a directional key pad and switches for Enter, Menu, Cancel and Info. For more information see MGC documents LT-895MP and LT-6033MP and LT-6738MP.

Models

- **RAXN-4000LCD or RAXN-4000LCDG or RAXN-4000LCDGC:** Main Annunciator Chassis with Common Indicators and Controls.
- **RAX-1048TZDS:** Adder Annunciator Chassis with 48 Circuit Capacity.
- **IPS-4848DS:** Programmable Input Switches module with 48 display points and 24 buttons.

ENCLOSURES for RAXN-4000LCD and RAXN-4000LCDG and RAXN-4000LCDGC

- **BB-1001D/DR/DS** With capacity for one Annunciator Chassis.
- **BB-1002D/DR/DS** With capacity for two Annunciator Chassis.
- **BB-1003D/DR/DS** With capacity for three Annunciator Chassis.
- **BB-1008D/DR/DS** With capacity for eight Annunciator Chassis.
- **BB-1012D/DR/DS** With capacity for twelve Annunciator Chassis.



Finish: Painted, textured, off-white (standard) (for other paint available colours and finishes, please contact factory)

Material: 18 G.A. cold roll steel (CRS)

Appendix C: DIP Switch Settings

FX-6000MNS-CH Network Main Board Address Setting (DIP SWITCH SW2)

Node Address	SW2 DIP SWITCHES							
	SW2-1	SW2-2	SW2-3	SW2-4	SW2-5	SW2-6	SW2-7	SW2-8
1	ON	OFF	OFF	OFF	OFF	OFF		
2	OFF	ON	OFF	OFF	OFF	OFF		
3	ON	ON	OFF	OFF	OFF	OFF		
4	OFF	OFF	ON	OFF	OFF	OFF		
5	ON	OFF	ON	OFF	OFF	OFF		
6	OFF	ON	ON	OFF	OFF	OFF		
7	ON	ON	ON	OFF	OFF	OFF		
8	OFF	OFF	OFF	ON	OFF	OFF		
9	ON	OFF	OFF	ON	OFF	OFF		
10	OFF	ON	OFF	ON	OFF	OFF		
11	ON	ON	OFF	ON	OFF	OFF		
12	OFF	OFF	ON	ON	OFF	OFF		
13	ON	OFF	ON	ON	OFF	OFF		
14	OFF	ON	ON	ON	OFF	OFF		
15	ON	ON	ON	ON	OFF	OFF		
16	OFF	OFF	OFF	OFF	ON	OFF		
17	ON	OFF	OFF	OFF	ON	OFF		
18	OFF	ON	OFF	OFF	ON	OFF		
19	ON	ON	OFF	OFF	ON	OFF		
20	OFF	OFF	ON	OFF	ON	OFF		
21	ON	OFF	ON	OFF	ON	OFF		
22	OFF	ON	ON	OFF	ON	OFF		
23	ON	ON	ON	OFF	ON	OFF		
24	OFF	OFF	OFF	ON	ON	OFF		
25	ON	OFF	OFF	ON	ON	OFF		
26	OFF	ON	OFF	ON	ON	OFF		
27	ON	ON	OFF	ON	ON	OFF		
28	OFF	OFF	ON	ON	ON	OFF		
29	ON	OFF	ON	ON	ON	OFF		
30	OFF	ON	ON	ON	ON	OFF		
31	ON	ON	ON	ON	ON	OFF		
32	OFF	OFF	OFF	OFF	OFF	ON		
33	ON	OFF	OFF	OFF	OFF	ON		
34	OFF	ON	OFF	OFF	OFF	ON		
35	ON	ON	OFF	OFF	OFF	ON		
36	OFF	OFF	ON	OFF	OFF	ON		
37	ON	OFF	ON	OFF	OFF	ON		
38	OFF	ON	ON	OFF	OFF	ON		
39	ON	ON	ON	OFF	OFF	ON		
40	OFF	OFF	OFF	ON	OFF	ON		
41	ON	OFF	OFF	ON	OFF	ON		
42	OFF	ON	OFF	ON	OFF	ON		
43	ON	ON	OFF	ON	OFF	ON		
44	OFF	OFF	ON	ON	OFF	ON		
45	ON	OFF	ON	ON	OFF	ON		
46	OFF	ON	ON	ON	OFF	ON		
47	ON	ON	ON	ON	OFF	ON		
48	OFF	OFF	OFF	OFF	ON	ON		
49	ON	OFF	OFF	OFF	ON	ON		
50	OFF	ON	OFF	OFF	ON	ON		
51	ON	ON	OFF	OFF	ON	ON		
52	OFF	OFF	ON	OFF	ON	ON		
53	ON	OFF	ON	OFF	ON	ON		
54	OFF	ON	ON	OFF	ON	ON		
55	ON	ON	ON	OFF	ON	ON		
56	OFF	OFF	OFF	ON	ON	ON		
57	ON	OFF	OFF	ON	ON	ON		
58	OFF	ON	OFF	ON	ON	ON		
59	ON	ON	OFF	ON	ON	ON		
60	OFF	OFF	ON	ON	ON	ON		
61	ON	OFF	ON	ON	ON	ON		
62	OFF	ON	ON	ON	ON	ON		
63	ON	ON	ON	ON	ON	ON		

FX-400X-XX Network Main Board Address Setting

Leave in "OFF" position as Factory Set.

Leave in "OFF" position as Factory Set.

ANC-6000 Audio Network Controller Board Address Setting (DIP SWITCH SW1)

ANC-6000	ADDR	SW1-1	SW1-2	SW1-3	SW1-4	SW1-5	SW1-6	SW1-7	SW1-8
	1	ON	OFF	OFF	OFF	OFF	OFF	OFF	OFF
	2	OFF	ON	OFF	OFF	OFF	OFF	OFF	OFF
	3	ON	ON	OFF	OFF	OFF	OFF	OFF	OFF
	4	OFF	OFF	ON	OFF	OFF	OFF	OFF	OFF
	5	ON	OFF	ON	OFF	OFF	OFF	OFF	OFF
	6	OFF	ON	ON	OFF	OFF	OFF	OFF	OFF
	7	ON	ON	ON	OFF	OFF	OFF	OFF	OFF

ALCN-960MISO/ALCN-4792MISO Loop Adder Module (CPU) Address Setting (DIP SWITCH SW1)

ALCN-960MISO/ ALCN-4792MISO	ADDR	SW1-1	SW1-2	SW1-3	SW1-4	SW1-5	SW1-6	SW1-7	SW1-8
	1	ON	OFF	OFF	OFF	OFF	OFF	OFF	OFF
	2	OFF	ON	OFF	OFF	OFF	OFF	OFF	OFF
	3	ON	ON	OFF	OFF	OFF	OFF	OFF	OFF
	4	OFF	OFF	ON	OFF	OFF	OFF	OFF	OFF
	5	ON	OFF	ON	OFF	OFF	OFF	OFF	OFF
	6	OFF	ON	ON	OFF	OFF	OFF	OFF	OFF
	7	ON	ON	ON	OFF	OFF	OFF	OFF	OFF

Put in "ON" position for firmware restore to defaults during power up. At all other times put in "OFF" state.

RAXN-4000LCD/RAXN-4000LCDG Remote Annunciator Address Setting (DIP SWITCH SW1)

RAXN-4000LCD/ RAXN-4000LCDG	ADDR	SW1-1	SW1-2	SW1-3	SW1-4	SW1-5	SW1-6	SW1-7	SW1-8
	33	ON	OFF	OFF	OFF	OFF	ON	Leave in "OFF" position as Factory Set.	
	34	OFF	ON	OFF	OFF	OFF	ON		
	35	ON	ON	OFF	OFF	OFF	ON		
	36	OFF	OFF	ON	OFF	OFF	ON		
	37	ON	OFF	ON	OFF	OFF	ON		
	38	OFF	ON	ON	OFF	OFF	ON		
	39	ON	ON	ON	OFF	OFF	ON		

RAXN-4000LCDGC Remote Annunciator Address Setting (SW4 and SW5)

Each RAXN-4000LCDGC must be assigned a unique address on the 2 dials SW4 and SW5 located on the back of the unit.

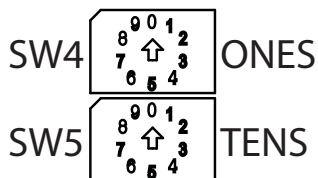
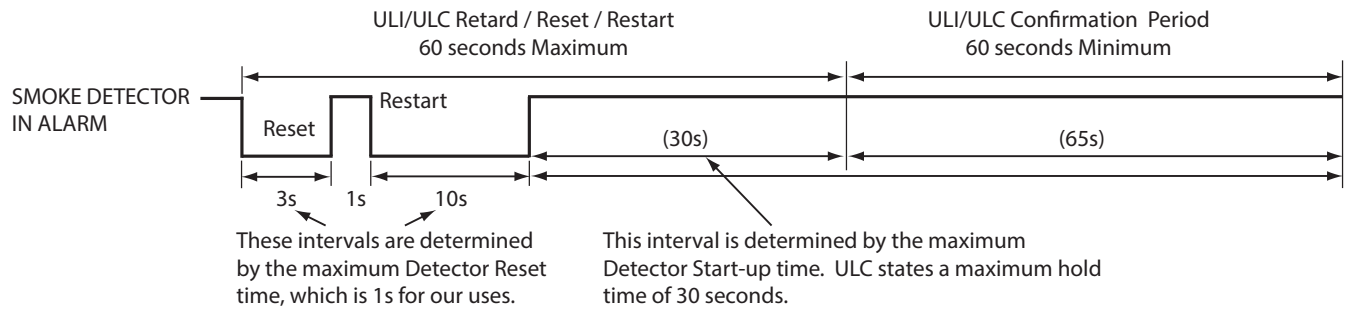

Figure 83 Address Dials

For example, to set the address 34, turn SW4 to 4 and SW5 to 3.

The valid range of addresses is 33 to 39.

Appendix D: Alarm Verification Timing



A Manual Station, or other contact-closure device, would remain shorted and be detected during the very short Zone Power burst within the first three seconds. A Smoke Detector will have been reset, and will require some minimum time to power-up, thus the Verification cycle will be entered.

Appendix E: Wiring For Addressable Supervised Output Module

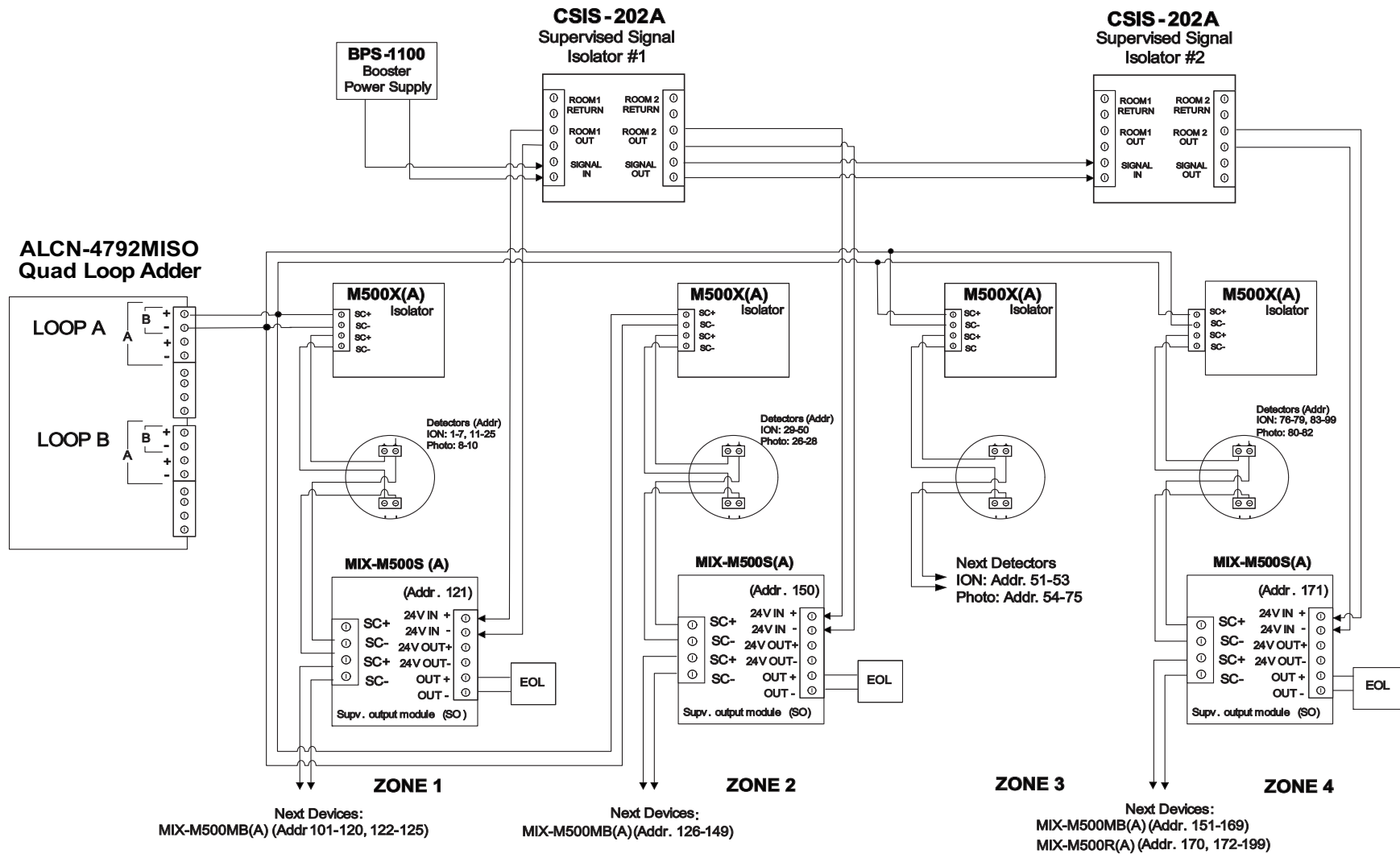

WIRING FOR ADDRESSABLE SUPERVISED OUTPUT MODULE TO COMPLY WITH UL 864 REV. 9

Appendix F: Power Supply and Batteries for Audio Expansion Cabinet QBB-6001

Use the form below to determine the required main chassis and secondary power supply (batteries).

IMPORTANT NOTICE							
The main AC branch circuit connection for Fire Alarm Control Unit must provide a dedicated continuous power without provision of any disconnect devices. Use #12 AWG wire with 600-volt insulation and proper over-current circuit protection that complies with the local codes. Refer to Appendix A for specifications.							
Power Requirements (All currents are in amperes)							
Model Number	Description	Qty		Standby (Amps)	Total Standby (Amps)	Alarm (Amps)	Total Alarm (Amps)
QCC-6000	Communication Card		X	0.0714	=	0.077	=
QAD-6425-70	100W Amplifier		X	0.270	=	5.97	=
QAD-6425-25	100W Amplifier		X	0.314	=	5.62	=
Total audio power in watts						0.065/watt	=
Total currents (add above currents)				STANDBY	(A)		(B)

Total Current Requirement: ALARM (B) _____ amps.

Battery Capacity Requirement:

$$([\text{STANDBY (A) } ______] \times [(24 \text{ or } 60 \text{ Hours) } ______]) + ([\text{ALARM (B) } ______] \times [\text{\$Alarm in Hr.} ______]) = (\text{C) } ______ \text{Ah}$$

Battery Selection: Multiply answer above (C) by 1.25 to derate battery.

Batteries: BAT-12V55 (55Ah).

§ Use 0.084 for five minutes of alarm or 0.5 for thirty minutes of alarm as a multiplier figure.



Note: Separate calculations must be completed for each QBB-6001.

Appendix G: APB-200/COA Sounder Bases

The FleX-Net™ FX-4000 Network Fire Alarm system can accommodate up to 32 APB-200/COA sounder bases per panel (node). The sounder base audio is synchronized on the same loop basis.

Below is a wiring diagram for connecting the sounder bases to auxiliary power with supervision.

Figure 84 Sounder Base Wiring to Auxiliary Power Supply with Supervision (Class B only)

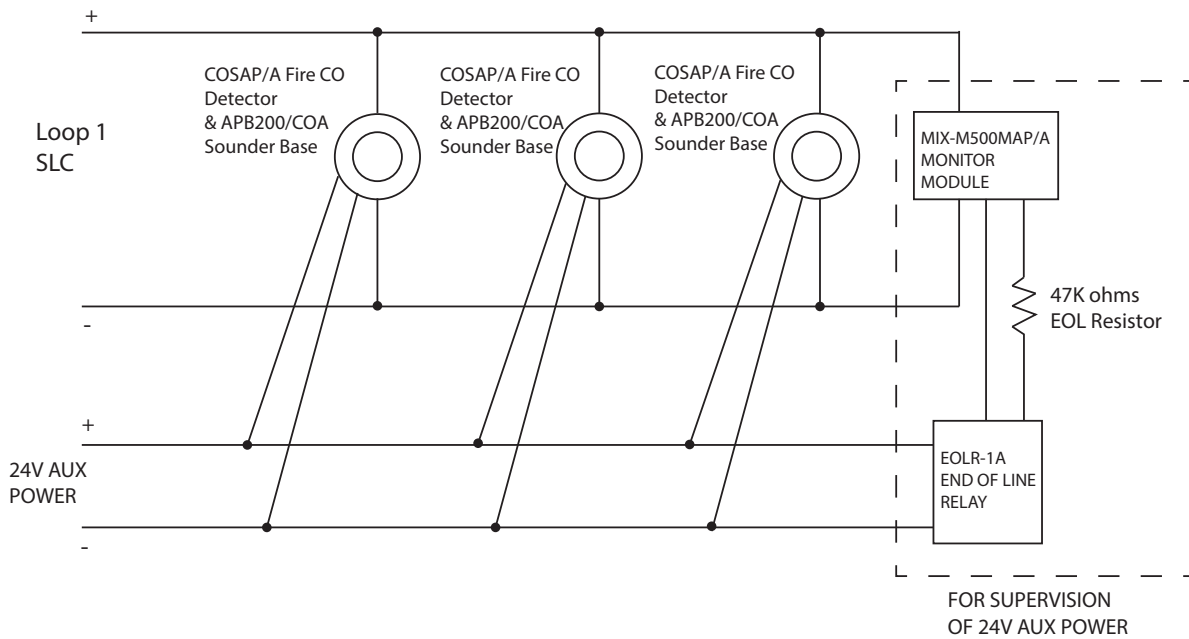

The monitor module (shown in the diagram above) should be set up in the configurator to report as a trouble input with the message tag "Sounder Base Fault".

Appendix H: ULC Compatible Speakers with Temporal 520Hz Square Wave Low Frequency Signal

Mircom Amplifier

Model	Description
QAD-6425-70	70V Amplifier, maximum four speaker zones
QAD-6425-25	25V Amplifier, maximum four speaker zones

Mircom Temporal 520Hz Square Wave Low Frequency Signal

Refer to the following table for required audio clip selection in the Configurator library for UL application according to the speaker manufacturer and temporal pattern.

Speaker/Strobe Manufacturer	Temporal Pattern	Temporal 520Hz Square Wave Low Frequency Signal Setting
Mircom SP series	Temporal 3	Mircom SP 520Hz 25-70V Temporal 3
	Temporal 4	Mircom SP 520Hz 25-70V Temporal 4
MGC SPP series and SPPS series	Temporal 3	MGC SPP & SPPS 520Hz 25-70V Temporal 3
	Temporal 4	MGC SPP & SPPS 520Hz 25-70V Temporal 4

Mircom Speakers

Model	Description	Back Box
SP-108-25(W)	8" Round Speaker, 25V, white or bright white	Flush mount box IB-108 or surface mount box IB-308
SP-108-70(W)	8" Round Speaker, 70V, white or bright white	Flush mount box IB-108 or surface mount box IB-308
SP-204A-25(W)	4" Square Speaker, 25V, white or bright white	Flush mount box IB-204 or surface mount box IB-404
SP-204A-70(W)	4" Square Speaker, 70V, white or bright white	Flush mount box IB-204 or surface mount box IB-404
SP-208-25(W)	8" Square Speaker, 25V, white or bright white	Flush mount box IB-208 or surface mount box IB-408

Model	Description	Back Box
SP-208-70(W)	8" Square Speaker, 70V, white or bright white	Flush mount box IB-208 or surface mount box IB-408
SP-304A-25(W)	4" Rectangular Retrofit Speaker, 25V, white or bright white	Flush mount box IB-2A
SP-304A-70(W)	4" Rectangular Retrofit Speaker, 70V, white or bright white	Flush mount box IB-2A
SP-404-70A(W)	In-suite Silenceable 4" Round Speaker, 70V, white or bright white	Flush mount box IB-104
SP-404SW-70A(W)	In Suite Silenceable 4" Round Speaker, 70V, white or bright white	Flush mount box IB-104
SP-504-70A(W)	In-suite Silenceable 4" Square Speaker, 70V, white or bright white	Flush mount box IB-204 or surface mount box IB-404
SP-504SW-70A(W)	In-suite Silenceable 4" Square Speaker, 70V, white or bright white	Flush mount box IB-204 or surface mount box IB-404

MGC Speakers and Speaker Strobes

Model	Description	Back Box
SPP-104-25	Round Speaker, Ceiling Mount, 25V, Low Profile, White	IB-104 or standard 4" square 2 1/8" deep electrical box with SPKC-W spacer attached
SPP-104-25R	Round Speaker, Ceiling Mount, 25V, Low Profile, Red	IB-104 or standard 4" square 2 1/8" deep electrical box with SPKC-W spacer attached
SPP-104-70	Round Speaker, Ceiling Mount, 70V, Low Profile, White	IB-104 or standard 4" square 2 1/8" deep electrical box with SPKC-W spacer attached
SPP-104-70R	Round Speaker, Ceiling Mount, 70V, Low Profile, Red	IB-104 or standard 4" square 2 1/8" deep electrical box with SPKC-W spacer attached
SPP-204-25	Square Speaker, Wall Mount, 25V, White	Flush mount on a 4" square 2 1/8" deep box
SPP-204-25R	Square Speaker, Wall Mount, 25V, Red	Flush mount on a 4" square 2 1/8" deep box
SPP-204-70	Square Speaker, Wall Mount, 70V, White	Flush mount on a 4" square 2 1/8" deep box
SPP-204-70R	Square Speaker, Wall Mount 70V, Red	Flush mount on a 4" square 2 1/8" deep box

Model	Description	Back Box
SPPS-104-25	Round Speaker/Strobe Ceiling Mount 25V Low Profile White	IB-104 or standard 4" square 2 1/8" deep electrical box with SPKC-W spacer attached
SPPS-104-25H	Round Speaker/Strobe, Ceiling Mount, 25V, Low Profile, White	IB-104 or standard 4" square 2 1/8" deep electrical box with SPKC-W spacer attached
SPPS-104-25HR	Round Speaker/Strobe, Ceiling Mount, 25V, Low Profile, Red	IB-104 or standard 4" square 2 1/8" deep electrical box with SPKC-W spacer attached
SPPS-104-25R	Round Speaker/Strobe, Ceiling Mount, 25V, Low Profile Red	IB-104 or standard 4" square 2 1/8" deep electrical box with SPKC-W spacer attached
SPPS-104-70	Round Speaker/Strobe, Ceiling Mount 70V Low Profile White	IB-104 or standard 4" square 2 1/8" deep electrical box with SPKC-W spacer attached
SPPS-104-70H	Round Speaker/Strobe, Ceiling Mount, 70V, Low Profile, White	IB-104 or standard 4" square 2 1/8" deep electrical box with SPKC-W spacer attached
SPPS-104-70HR	Round Speaker/Strobe, Ceiling Mount, 70V, Low Profile, Red	IB-104 or standard 4" square 2 1/8" deep electrical box with SPKC-W spacer attached
SPPS-104-70R	Round Speaker/Strobe, Ceiling Mount, 70V, Low Profile Red	IB-104 or standard 4" square 2 1/8" deep electrical box with SPKC-W spacer attached
SPPS-204-25	Square Speaker/Strobe, Wall Mount, 25V, White	Flush mount on a 4" square 2 1/8" deep box
SPPS-204-25R	Square Speaker/Strobe, Wall Mount, 25V, Red	Flush mount on a 4" square 2 1/8" deep box
SPPS-204-70	Square Speaker/Strobe, Wall Mount, 70V, White	Flush mount on a 4" square 2 1/8" deep box
SPPS-204-70R	Square Speaker/Strobe, Wall Mount, 70V, Red	Flush mount on a 4" square 2 1/8" deep box

Appendix I: UL Compatible Speakers with Temporal 520Hz Square Wave Low Frequency Signal

Mircom Amplifier

Model	Description
QAD-6425-70	70V Amplifier, maximum four speaker zones
QAD-6425-25	25V Amplifier, maximum four speaker zones

Mircom Temporal 520Hz Square Wave Low Frequency Signal

Refer to the following table for required audio clip selection in the Configurator library for UL application according to the speaker manufacturer and temporal pattern.

Speaker/Strobe Manufacturer	Temporal Pattern	Temporal 520Hz Square Wave Low Frequency Signal Setting
MGC SPP series and SPSS series	Temporal 3	MGC SPP & SPSS 520Hz 25-70V Temporal 3
	Temporal 4	MGC SPP & SPSS 520Hz 25-70V Temporal 4

MGC Speakers and Speaker Strobes

Model	Description	Back Box
SPP-104-25	Round Speaker, Ceiling Mount, 25V, Low Profile, White	IB-104 or standard 4" square 2 1/8" deep electrical box with SPKC-W spacer attached
SPP-104-25R	Round Speaker, Ceiling Mount, 25V, Low Profile, Red	IB-104 or standard 4" square 2 1/8" deep electrical box with SPKC-W spacer attached
SPP-104-70	Round Speaker, Ceiling Mount, 70V, Low Profile, White	IB-104 or standard 4" square 2 1/8" deep electrical box with SPKC-W spacer attached
SPP-104-70R	Round Speaker, Ceiling Mount, 70V, Low Profile, Red	IB-104 or standard 4" square 2 1/8" deep electrical box with SPKC-W spacer attached
SPP-204-25	Square Speaker, Wall Mount, 25V, White	Flush mount on a 4" square 2 1/8" deep box

Model	Description	Back Box
SPP-204-25R	Square Speaker, Wall Mount, 25V, Red	Flush mount on a 4" square 2 1/8" deep box
SPP-204-70	Square Speaker, Wall Mount, 70V, White	Flush mount on a 4" square 2 1/8" deep box
SPP-204-70R	Square Speaker, Wall Mount 70V, Red	Flush mount on a 4" square 2 1/8" deep box
SPPS-104-25	Round Speaker/Strobe Ceiling Mount 25V Low Profile White	IB-104 or standard 4" square 2 1/8" deep electrical box with SPKC-W spacer attached
SPPS-104-25H	Round Speaker/Strobe, Ceiling Mount, 25V, Low Profile, White	IB-104 or standard 4" square 2 1/8" deep electrical box with SPKC-W spacer attached
SPPS-104-25HR	Round Speaker/Strobe, Ceiling Mount, 25V, Low Profile, Red	IB-104 or standard 4" square 2 1/8" deep electrical box with SPKC-W spacer attached
SPPS-104-25R	Round Speaker/Strobe, Ceiling Mount, 25V, Low Profile Red	IB-104 or standard 4" square 2 1/8" deep electrical box with SPKC-W spacer attached
SPPS-104-70	Round Speaker/Strobe, Ceiling Mount 70V Low Profile White	IB-104 or standard 4" square 2 1/8" deep electrical box with SPKC-W spacer attached
SPPS-104-70H	Round Speaker/Strobe, Ceiling Mount, 70V, Low Profile, White	IB-104 or standard 4" square 2 1/8" deep electrical box with SPKC-W spacer attached
SPPS-104-70HR	Round Speaker/Strobe, Ceiling Mount, 70V, Low Profile, Red	IB-104 or standard 4" square 2 1/8" deep electrical box with SPKC-W spacer attached
SPPS-104-70R	Round Speaker/Strobe, Ceiling Mount, 70V, Low Profile Red	IB-104 or standard 4" square 2 1/8" deep electrical box with SPKC-W spacer attached
SPPS-204-25	Square Speaker/Strobe, Wall Mount, 25V, White	Flush mount on a 4" square 2 1/8" deep box
SPPS-204-25R	Square Speaker/Strobe, Wall Mount, 25V, Red	Flush mount on a 4" square 2 1/8" deep box
SPPS-204-70	Square Speaker/Strobe, Wall Mount, 70V, White	Flush mount on a 4" square 2 1/8" deep box
SPPS-204-70R	Square Speaker/Strobe, Wall Mount, 70V, Red	Flush mount on a 4" square 2 1/8" deep box

Appendix J: Example Configuration Setup

Example Configuration Setup

Here is the drawing of a sample hardware setup that represents new components within the FX-MNS-6000 product and their connection with the existing FleX-Net™ FX-4000 system.

Figure 85 Example Setup

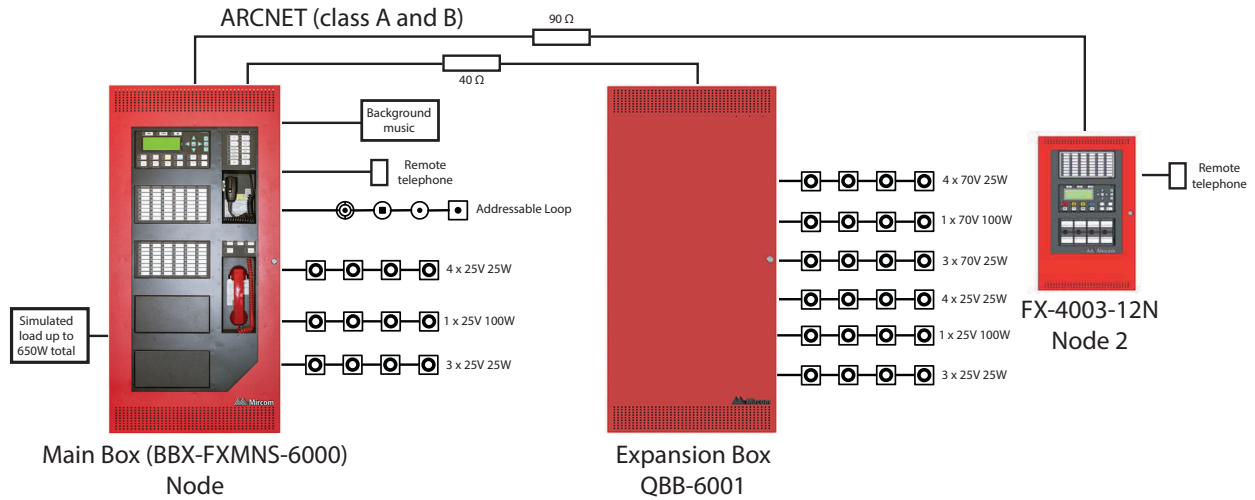

Node Builds

Table 34: Node Builds

Description	Part Number	Qty
Node 1: MAIN PANEL		
Main Box	BBX-FXMNS-6000	1
Main board	MD-871A	1
Telephone network controller	TNC-5000	1
Fire Network Controller	FNC-2000	1
Vertical Master Paging Module	QMP-6101NV	1
Vertical Master Telephone Module	QMT-5302NV	1
Main Display	DSPL-420DS	1
Page Selector	QAZT-5302DS	2
Signal adder module	SGM-1004A	1
Audio Network Controller Module	ANC-6000	1
Communication card	QCC-6000	1

Table 34: Node Builds (Continued)

Description	Part Number	Qty
Power supply	QPS-6650	1
25V amplifier	QAD-6425-25	3
Quad Analog Loops	ALCN-4792MISO	1
Amplifier cage	QMB-6000	1
48 LED Adder (for UL tests)	RAX-1048TZDS	1
48 Switch Adder (for ULC tests)	IPS-4848DS	1
Node 1: EXPANSION PANEL		
Expansion Box	QBB-6001	1
Amplifier cage	QMB-6000	2
25V amplifier	QAD-6425-25	3
70V amplifier	QAD-6425-70	3
Communication card	QCC-6000	1
Power supply	QPS-6650	1
Node 2: MMX-4003-12N		
Enclosure	BBX-1024DS	1
Main board	MD-871A	1
Narrow Main Display	DSPL-420DS	1
Telephone network controller	TNC-5000	1
Fire Network Controller	FNC-2000	1
Audio Network Controller Module	ANC-6000	1

Configuring the Hardware

1. Create a new job.

Figure 86 New Job

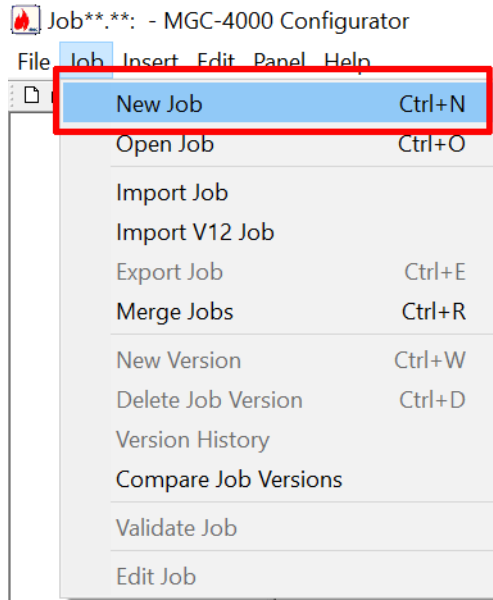

2. Enter in the description of the job and select the Agency Standard.

Figure 87 New Job Description

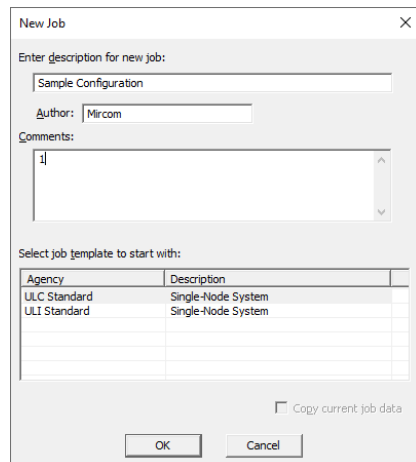

- In the **Job Details** pane, select **Monitor Alert**. This option allows the display and the buzzer on nodes 1 and 2 to show the event.

Figure 88 Job Details

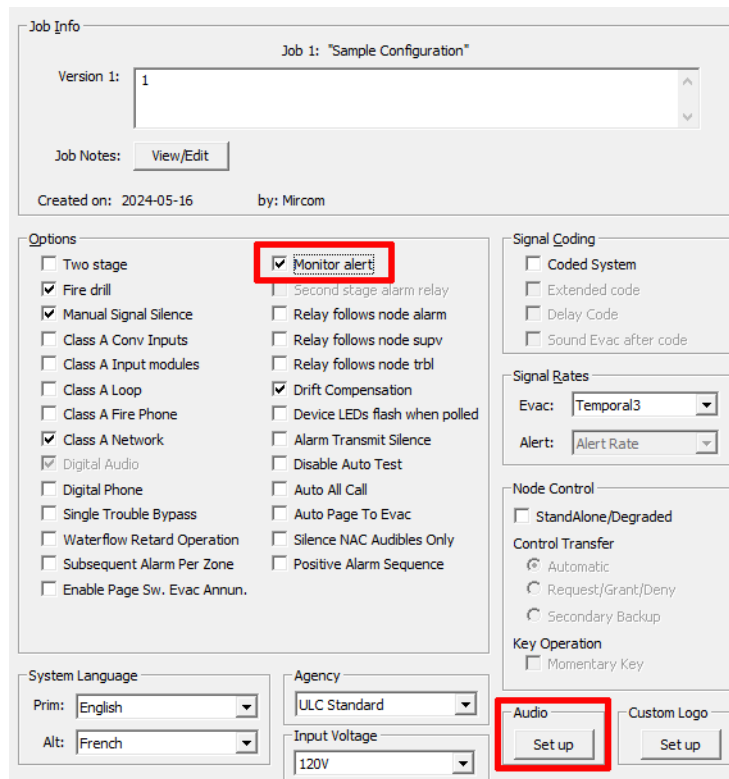

Job Info
Job 1: "Sample Configuration"

Version 1: 1

Job Notes: View/Edit

Created on: 2024-05-16 by: Mircom

Options

- Two stage
- Fire drill
- Manual Signal Silence
- Class A Conv Inputs
- Class A Input modules
- Class A Loop
- Class A Fire Phone
- Class A Network
- Digital Audio
- Digital Phone
- Single Trouble Bypass
- Waterflow Retard Operation
- Subsequent Alarm Per Zone
- Enable Page Sw. Evac Annun.
- Monitor alert
- Second stage alarm relay
- Relay follows node alarm
- Relay follows node supv
- Relay follows node trbl
- Drift Compensation
- Device LEDs flash when polled
- Alarm Transmit Silence
- Disable Auto Test
- Auto All Call
- Auto Page To Evac
- Silence NAC Audibles Only
- Positive Alarm Sequence

Signal Coding

- Coded System
- Extended code
- Delay Code
- Sound Evac after code

Signal Rates

Evac: Temporal3

Alert: Alert Rate

Node Control

- StandAlone/Degraded

Control Transfer

- Automatic
- Request/Grant/Deny
- Secondary Backup

Key Operation

- Momentary Key

System Language

Prim: English

Alt: French

Agency

ULC Standard

Input Voltage

120V

Audio Set up

Custom Logo Set up

- Click **Setup** under **Audio**.
- Select **Digital message continue after paging**. This option makes sure that the audio reverts to the previously initiated recorded message prior to paging. If this box is unchecked, then the audio goes back to silence upon completing the page operation.
- Modify the Alert and Evac messages to any custom message. Messages can be imported or composed based on pre-existing messages

Figure 89 Audio Setup

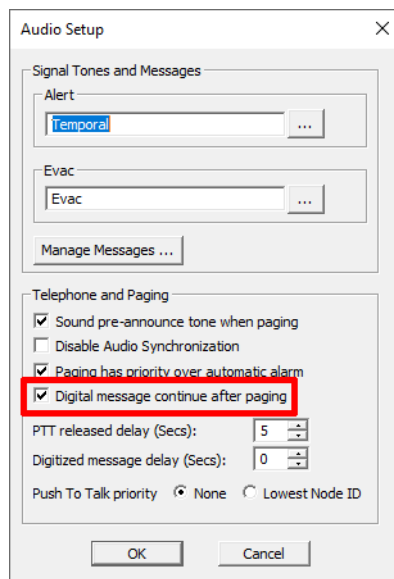

Audio Setup

Signal Tones and Messages

Alert: Temporal

Evac: Evac

Manage Messages ...

Telephone and Paging

- Sound pre-announce tone when paging
- Disable Audio Synchronization
- Paging has priority over automatic alarm
- Digital message continue after paging

PTT released delay (Secs): 5

Digitized message delay (Secs): 0

Push To Talk priority: None Lowest Node ID

OK Cancel

7. Click **OK** in the Audio Setup window.
8. Right-click Node 1 and select **Add Audio Controller**.

Figure 90 Add Audio Controller

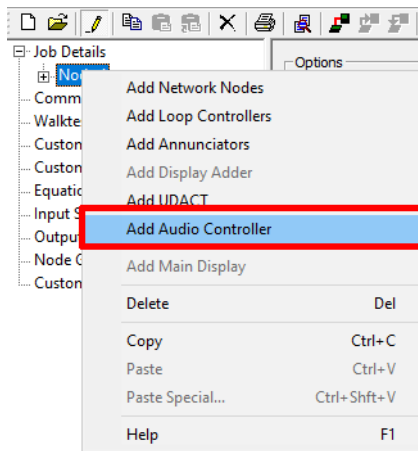

9. Select **ANC-6000**, then click **Add**.

Figure 91 Add ANC-6000

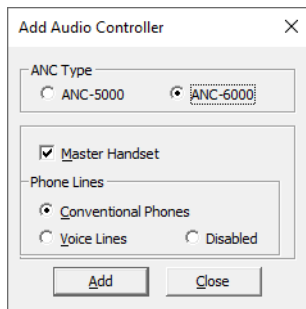

10. Right-click Node 1 and select **Add Loop Controllers**.

Figure 92 Add Loop Controllers

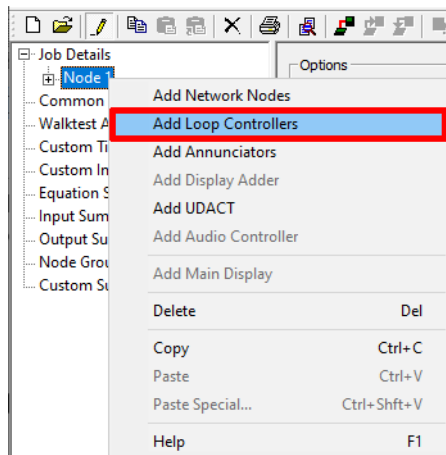

11. Select the loop controller in the **Type** menu, then click **Add**.

Figure 93 Add Loop Controller

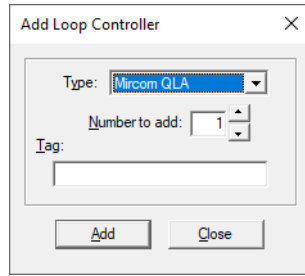

12. Right-click Node 1 and select **Add UDACT**.

Figure 94 Add UDACT

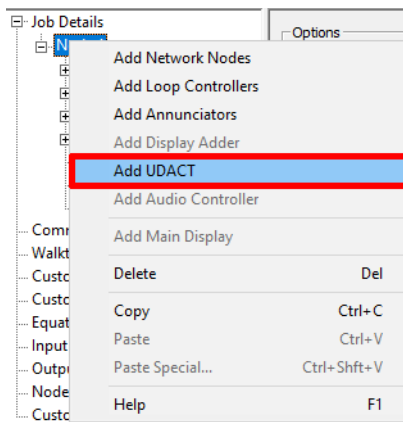

13. Select the report format, then click **Add**.

Figure 95 Add UDACT

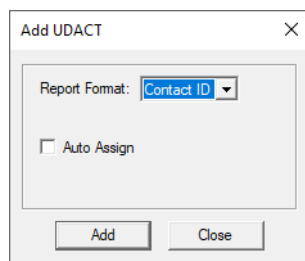

14. Right-click **Job Details** and select **Add Network Nodes** to add a second node.

Figure 96 Add Network Nodes

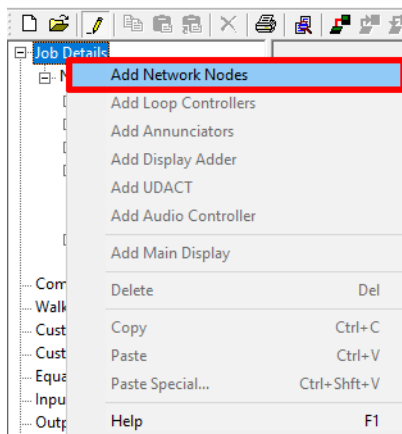

15. Click **Add** to add a new node.

Figure 97 Add Network Nodes

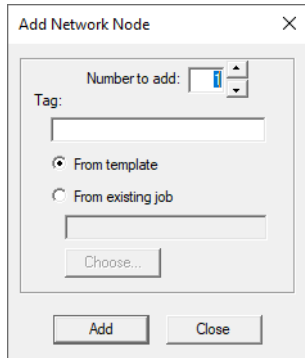

16. On Node 1, right-click **Main Display** and click **Add Display Adder**.

Figure 98 Add Display Adder

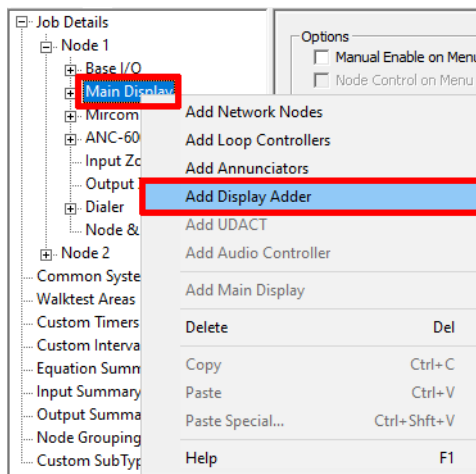

17. Add **Telephone/Page Selector**, **Master Telephone**, and **48 LED Adder**.

Figure 99 Add Display Adder

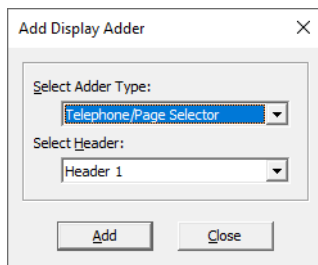

18. Right-click **ANC-6000** and select **Add Master Paging**. This adds the QMP-6101NV.

Figure 100 Add Master Paging

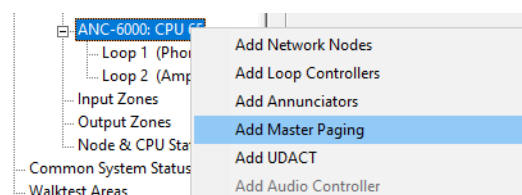

19. Select **Loop 2** under **ANC-6000**, then click **Insert** and click **Add Amplifier**.

Figure 101 Add Amplifier

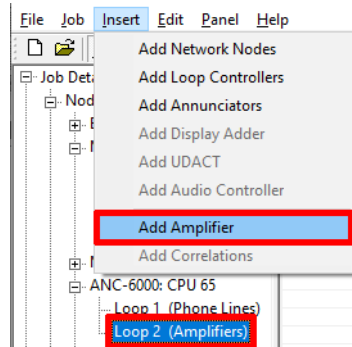

20. Select the type of the amplifier to add from the pop up window menu.

Figure 102 Add Amplifiers

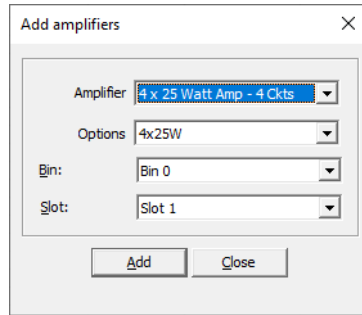

21. Add amplifiers based on the hardware configuration.



Note: The F2 column indicates how to set the jumpers on the amplifiers (section 11.2).

Figure 103 Amplifiers

Addr	Device	Type	SubType	F1	F2
0.1.1	25 Watt ClassD	Signal	None		
0.1.2	75 Watt ClassD	Signal	None		AJ2-3
0.1.3		Signal	None		AJ3-4
0.1.4		Signal	None		
0.2.1	75 Watt ClassD	Signal	None		AJ1-2
0.2.2		Signal	None		AJ2-3
0.2.3		Signal	None		
0.2.4	25 Watt ClassD	Signal	None		

22. Right-click **Loop 2** in the quad loop adder then click **Insert** and click **Add Device**.

Figure 104 Add Device

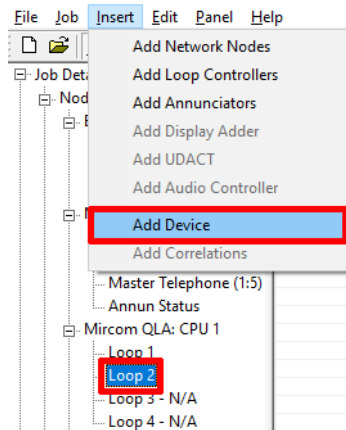

23. Add devices based on the hardware configuration.

Figure 105 Devices

Addr	Device	Type
1.1	Input	Alarm Input
1.2	Input	Latched Supv
2.1	Input	Monitor
2.2	Input	Alarm Input

Switch Assignments

1. Select the **Telephone/Page Selector** and configure the **Type** of the first three switches as **Page Select**.

Figure 106 Page Selector Switches

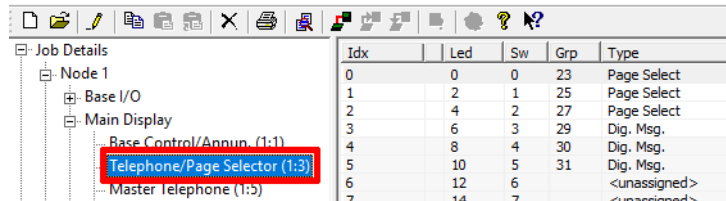

2. Configure three of the switches as **Dig. Msg.**

3. Assign some of the 48 LED adder indicators to show status of output zones (NACs and speakers).

Figure 107 LED Assignment

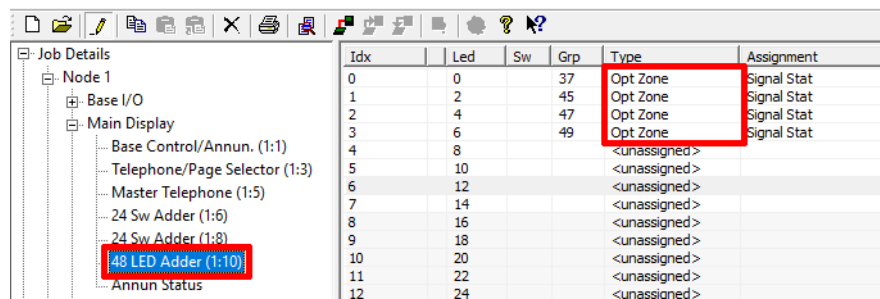

4. Right-click **Input Zones**, click **Insert**, then click **Add Zone**.

5. Add three input zones for each of Alarm, Supervisory and Monitor.

Figure 108 Add Zones

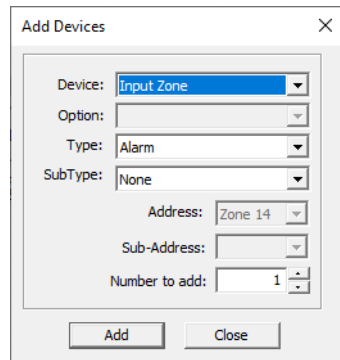

Here is the end result for the input zones.

Figure 109 Input Zones

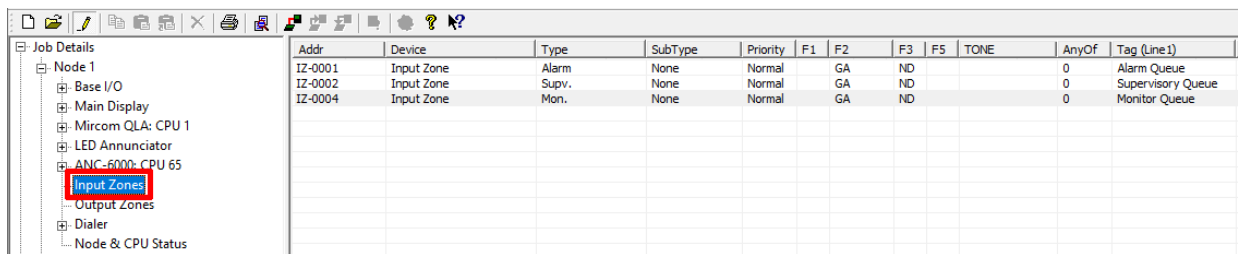

Addr	Device	Type	SubType	Priority	F1	F2	F3	F5	TO	AnyOf	Tag (Line1)
IZ-0001	Input Zone	Alarm	None	Normal		GA	ND			0	Alarm Queue
IZ-0002	Input Zone	Supv.	None	Normal		GA	ND			0	Supervisory Queue
IZ-0004	Input Zone	Mon.	None	Normal		GA	ND			0	Monitor Queue

6. Select **Loop 2** in the quad loop adder, right-click any of the inputs, and add correlations to input zones.

Figure 110 Add correlations to input zones

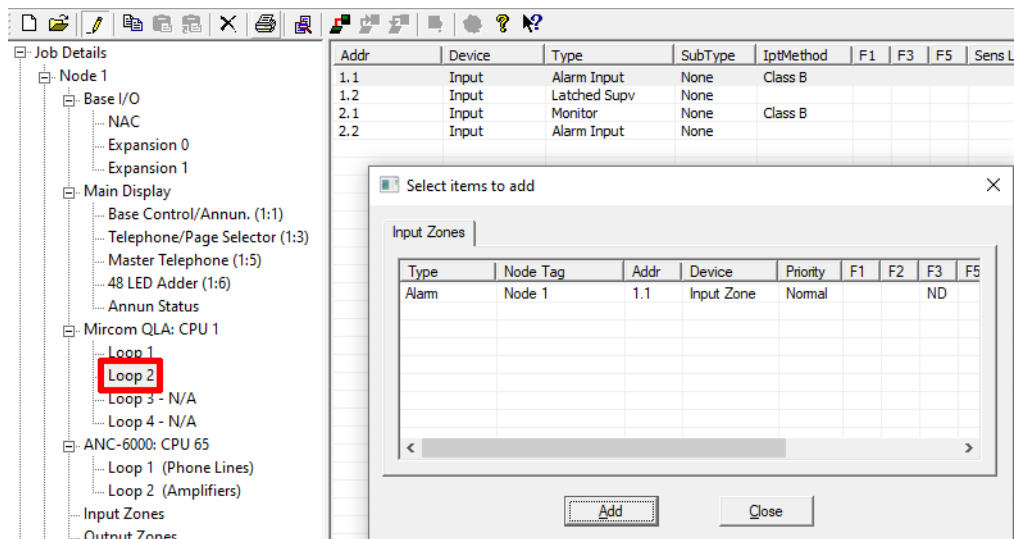

Addr	Device	Type	SubType	IptMethod	F1	F3	F5	Sens L
1.1	Input	Alarm Input	None	Class B				
1.2	Input	Latched Supv	None					
2.1	Input	Monitor	None	Class B				
2.2	Input	Alarm Input	None					

Type	Node Tag	Addr	Device	Priority	F1	F2	F3	F5
Alam	Node 1	1.1	Input Zone	Normal			ND	

7. Select all the amplifiers in **Loop 2** in **ANC-6000**.

1. Create a correlation to input alarm zone 1.

Figure 111 Add Correlations

Addr	Device	Type	SubType	F1	F2	F3	F4	Sens Lvl Pre	Sens	Sens Lvl 2	Sens Lvl 3	Tag (Line1)	Tag (Line2)
0.1.1	25 Watt Cl...	Signal	None										
0.1.2	25 Watt Cl...	Signal	None										
0.1.3	25 Watt Cl...	Signal	None										
0.1.4	25 Watt Cl...	Signal	None										
0.2.1	25 Watt Cl...	Signal	None										
0.2.2	25 Watt Cl...	Signal	None										
0.2.3	50 Watt Cl...	Signal	None		A...								
0.2.4		Signal	None										
0.3.1	25 Watt Cl...	Signal	None										
0.3.2	75 Watt Cl...	Signal	None		A...								
0.3.3		Signal	None		A...								
0.3.4		Signal	None										
0.4.1	75 Watt Cl...	Signal	None		A...								
0.4.2		Signal	None		A...								
0.4.3		Signal	None										
0.4.4	25 Watt Cl...	Signal	None										

Select items to add

Type	Node Tag	CPU	L...	Addr	Device	Priority	F1	F
Alarm	Node 1			1.1	Input Zone	Normal		

Add Close

2. Select the **48 LED Adder** under **Main Display** and create buttons for input zones and create correlations to their respective zones.

Figure 112 48 LED Adder input zones

Job Details

- Node 1
 - Base I/O
 - NAC
 - Expansion 0
 - Expansion 1
 - Main Display
 - Base Control/Annu. (1:1)
 - Telephone/Page Selector (1:3)
 - Master Telephone (1:5)
 - 48 LED Adder (1:6)**
 - Annu. Status

Idx	Led	Sw	Grp	Type	Assignment
0	0		32	Opt Zone	Signal Stat
1	2		36	Opt Zone	Signal Stat
2	4		34	Opt Zone	Signal Stat
3	6		38	Ipt Zone	Alarm Stat
4	8		40	Int Zone	Supervisory Stat
5	10	42	Ipt Zone	Monitor Stat	
6	12		<unassigned>		
7	14		<unassigned>		

Mon.

Type	Node Tag	CPU	L...	Addr	Device	Priority
Mon.	Node 1			3.1	Input Zone	Normal

Page Select Correlations

1. Select **Telephone/Page Selector** under **Main Display** and correlate the first **Page Select** button to the first amplifier card in the main panel.

Figure 113 Telephone/Page Selector amplifier correlations

Job Details

- Node 1
 - Base I/O
 - NAC
 - Expansion 0
 - Expansion 1
 - Main Display
 - Base Control/Annu. (1:1)
 - Telephone/Page Selector (1:3)**
 - Master Telephone (1:5)
 - 48 LED Adder (1:6)
 - Annu. Status
 - Mircom QLA: CPU 1
 - Loop 1
 - Loop 2
 - Loop 3 - N/A
 - Loop 4 - N/A
 - ANC-6000: CPU 65
 - Loop 1 (Phone Lines)
 - Loop 2 (Amplifiers)
 - Input Zones
 - Output Zones
 - Dialer
 - Node & CPU Status
- Node 2
 - Common System Status
 - Walktest Areas
 - Custom Timers
 - Custom Intervals

Idx	Led	Sw	Grp	Type	Assignment	Node Group	Priority	F1	F2	F3	Tag	Tag2	AllTag	AllTag2
0	0	0	23	Page Select										
1	2	1	25	Page Select										
2	4	2	27	Page Select										
3	6	3	29	Dig. Msg.										
4	8	4	30	Dig. Msg.										
5	10	5	31	Dig. Msg.										
6	12	6		<unassigned>										
7	14	7		<unassigned>										

Select items to add

Type	Node Tag	CPU	L...	Addr	Device	Priority	F1	F2	F3	Tag
Signal	Node 1	0	0	0	NAC OptCkt					Base Ss
Signal	Node 1	0	0	1	NAC OptCkt					Base Ss
Signal	Node 1	0	0	2	NAC OptCkt					Base Ss
Signal	Node 1	0	0	3	NAC OptCkt					Base Ss
Signal	Node 1	65	2	0.1.1	25 Watt ClassD					
Signal	Node 1	65	2	0.1.2	25 Watt ClassD					
Signal	Node 1	65	2	0.1.3	25 Watt ClassD					
Signal	Node 1	65	2	0.1.4	25 Watt ClassD					
Signal	Node 1	65	2	0.2.1	25 Watt ClassD					
Signal	Node 1	65	2	0.2.2	25 Watt ClassD					
Signal	Node 1	65	2	0.2.3	50 Watt ClassD					A...
Signal	Node 1	65	2	0.3.1	25 Watt ClassD					
Signal	Node 1	65	2	0.3.2	75 Watt ClassD					A...
Signal	Node 1	65	2	0.4.1	75 Watt ClassD					A...
Signal	Node 1	65	2	0.4.4	25 Watt ClassD					
Signal	Node 2	0	0	0	NAC OptCkt					Base Ss
Signal	Node 2	0	0	1	NAC OptCkt					Base Ss
Signal	Node 2	0	0	2	NAC OptCkt					Base Ss
Signal	Node 2	0	0	3	NAC OptCkt					Base Ss

Add Close

2. Correlate custom digital messages to the **Dig. Msg.** switches.

If the **Digitized Msgs** screen is empty, you need to add messages in the **Audio Setup**. See page 145.

Figure 114 Telephone/Page Selector digital message correlations

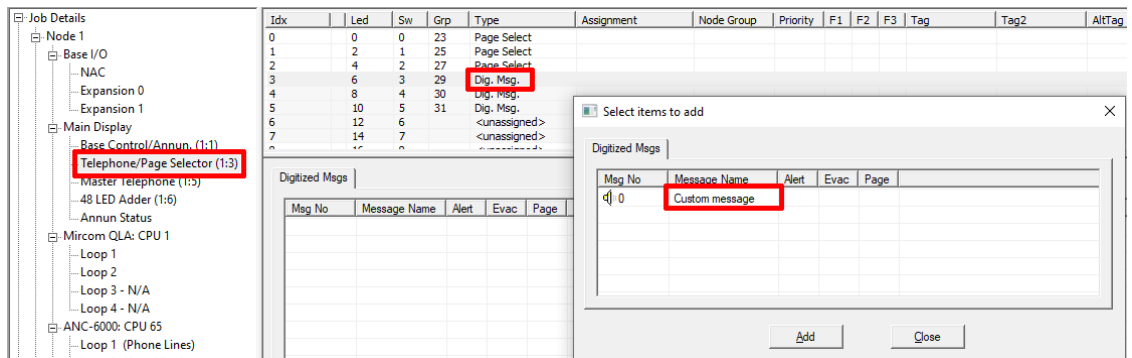

Dialer Configuration

1. Select **Dialer**.
2. Select **Loop Address**.

Figure 115 Dialer settings

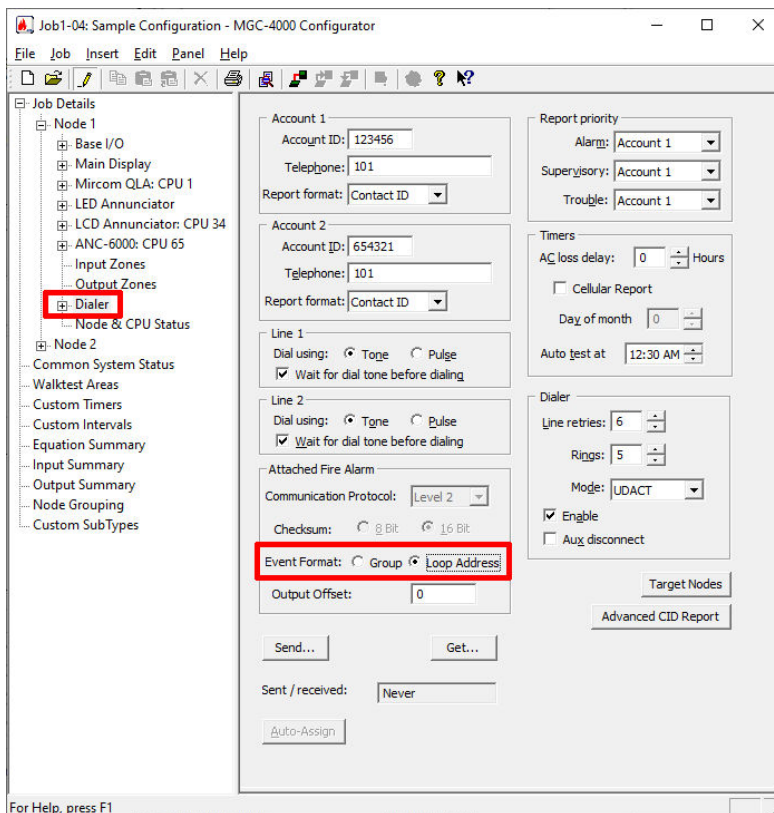

3. At the end of your configurations, validate the job by clicking **Job**, then **Validate Job**.

ULC Configurations (Changes to Satisfy ULC Requirements)

Hardware changes required for ULC compliance:

48 LED adder (RAX-1048TZDS) was changed to 48 switch adder (IPS-4848DS). The IPS-4848DS is represented by two **24 SW Adder** in the configurator.

Figure 116 2 x 24 SW Adder

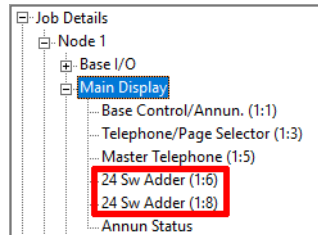

1. In order to modify an existing job for ULC, create a new job and change the agency to ULC and then copy current job date to it.
2. Make the following changes in the job details view to configure for two-stage.

Figure 117 Configure Job for Two Stage

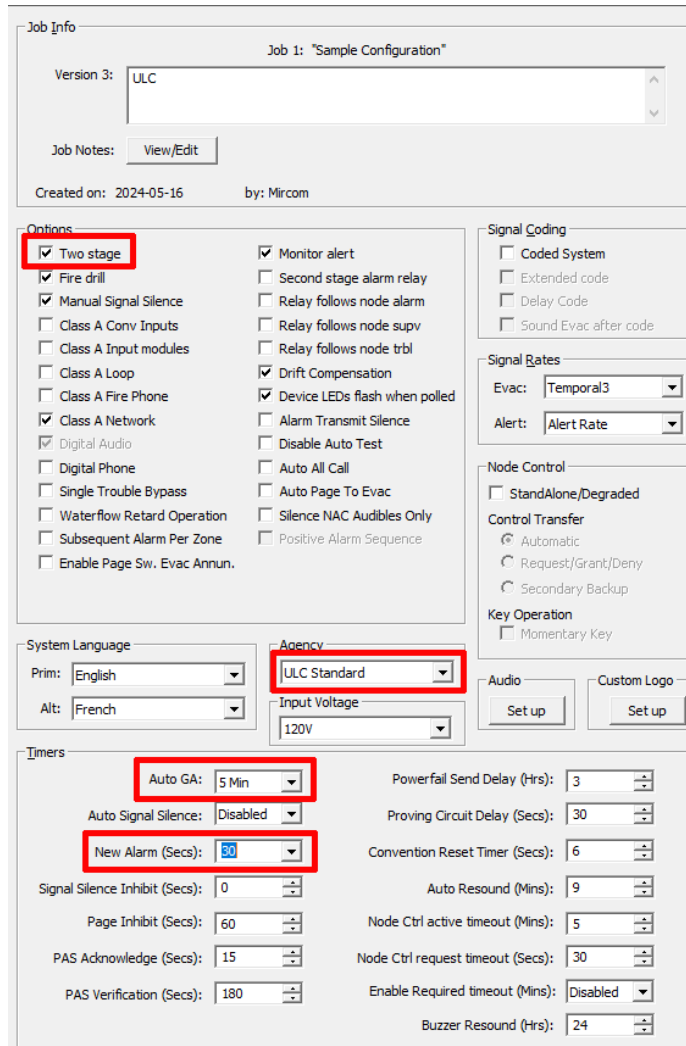

Job Info

Job 1: "Sample Configuration"

Version 3: ULC

Job Notes: [View/Edit](#)

Created on: 2024-05-16 by: Mircom

Options

- Two stage
- Fire drill
- Manual Signal Silence
- Class A Conv Inputs
- Class A Input modules
- Class A Loop
- Class A Fire Phone
- Class A Network
- Digital Audio
- Digital Phone
- Single Trouble Bypass
- Waterflow Retard Operation
- Subsequent Alarm Per Zone
- Enable Page Sw. Evac Annun.
- Monitor alert
- Second stage alarm relay
- Relay follows node alarm
- Relay follows node supv
- Relay follows node trbl
- Drift Compensation
- Device LEDs flash when polled
- Alarm Transmit Silence
- Disable Auto Test
- Auto All Call
- Auto Page To Evac
- Silence NAC Audibles Only
- Positive Alarm Sequence

Signal Coding

- Coded System
- Extended code
- Delay Code
- Sound Evac after code

Signal Rates

Evac: Temporal3

Alert: Alert Rate

Node Control

- StandAlone/Degraded

Control Transfer

- Automatic
- Request/Grant/Deny
- Secondary Backup

Key Operation

- Momentary Key

System Language

Prim: English

Alt: French

Agency

ULC Standard

Input Voltage

120V

Audio **Custom Logo**

[Set up](#) [Set up](#)

Timers

Auto GA: 5 Min

Auto Signal Silence: Disabled

New Alarm (Secs): 80

Signal Silence Inhibit (Secs): 0

Page Inhibit (Secs): 60

PAS Acknowledge (Secs): 15

PAS Verification (Secs): 180

Powerfail Send Delay (Hrs): 3

Proving Circuit Delay (Secs): 30

Convention Reset Timer (Secs): 6

Auto Resound (Mins): 9

Node Ctrl active timeout (Mins): 5

Node Ctrl request timeout (Secs): 30

Enable Required timeout (Mins): Disabled

Buzzer Resound (Hrs): 24

The **Two stage** option configures the system for a simple two-stage (the mall operation). The simple two stage puts all output zones into alert for the duration of the Auto GA. Upon expiring the Auto GA timer, all output zones go into Evac. Alternatively, a subsequent alarm puts all the output zones into Evac at any time prior to the expiry of the Auto GA timer.

- In order to configure the system for a modified two stage, correlate the **Node alarm** status to all the amplifiers in the system. This lets all the amplifiers sound the Alert signal when an initial Alarm is present in the system. Keep the F2 flag blank.

Figure 118 Correlate Node Alarm to Amplifiers

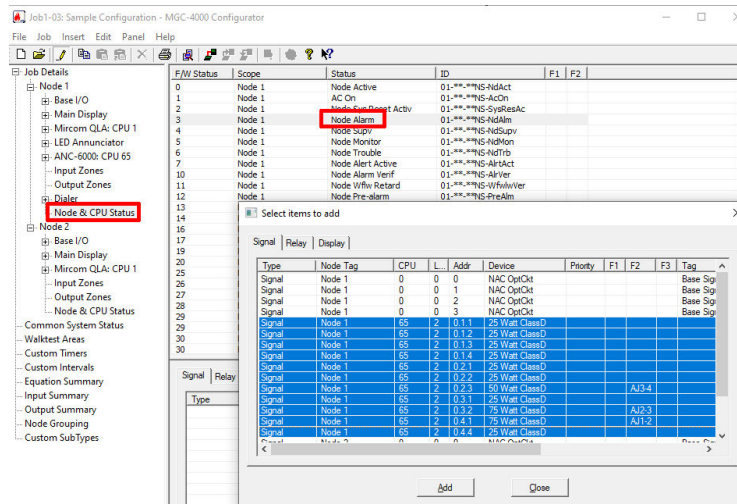

- Then, add input zones to represent physical floors of a building.

Figure 119 Add Input Zones

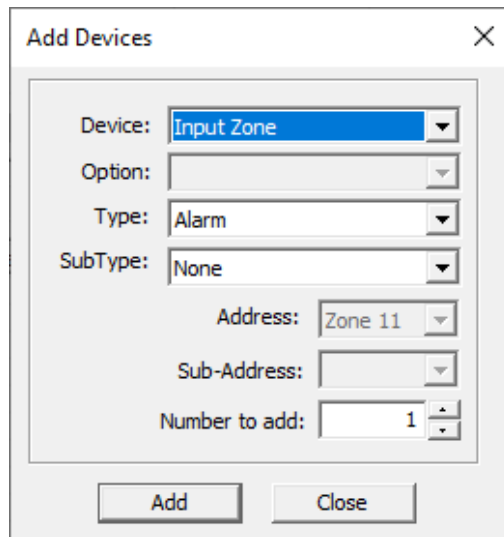

- Ensure you enable the GA flag in the F2 column. This puts the specific zones into Evac upon activation.

Figure 120 Enable GA Flag

Addr	Device	Type	SubType	Priority	F1	F2
IZ-0001	Input Zone	Alarm	None	Normal		
IZ-0002	Input Zone	Supv.	None	Normal		
IZ-0003	Input Zone	Trbl.	None	Normal		
IZ-0004	Input Zone	Mon.	None	Normal		
IZ-0005	Input Zone	Alarm	None	Normal		GA
IZ-0006	Input Zone	Alarm	None	Normal		GA
IZ-0007	Input Zone	Alarm	None	Normal		GA

- Add 3 Manual Stations to Loop 2.

Figure 121 Add Manual Stations

Addr	Device	Type	SubType	IptMethod
1.1	Input	Alarm Input	Manual Station	Class B
1.2	Input	Alarm Input	Manual Station	
2.1	Input	Alarm Input	Manual Station	Class B
2.2	Input	Alarm Input	Manual Station	
3.1	Input	Alarm Input	Manual Station	Class B
3.2	Input	Alarm Input	Manual Station	

- Correlate the manual stations to their respective input zones.

Figure 122 Correlate Manual Stations to Input Zones

Addr	Device	Type	SubType	IptMethod	F1	F2	F3	F5	Sens Lvl Pre	Sens
1.1	Input	Alarm Input	Manual Station	Class B						
1.2	Input	Alarm Input	Manual Station							
2.1	Input	Alarm Input	Manual Station	Class B						
2.2	Input	Alarm Input	Manual Station							
3.1	Input	Alarm Input	Manual Station	Class B						
3.2	Input	Alarm Input	Manual Station							

Select items to add

Input Zones

Type	Node Tag	Addr	Device	Priority	F1	F2	F3	F5	Tag
Alarm	Node 1	1.1	Input Zone	Normal	GA	ND			Floor 1
Alarm	Node 1	5.1	Input Zone	Normal	GA	ND			Floor 2
Alarm	Node 1	6.1	Input Zone	Normal	GA	ND			Floor 3

- Correlate input zones to signals (amplifier circuits) based on your physical configuration.

Figure 123 Correlate Input Zones to Signals

Addr	Device	Type	SubType	Priority	F1	F2	F3	F5	ZONE
IZ-0001	Input Zone	Alarm	None	Normal	GA	ND			
IZ-0002	Input Zone	Supv.	None	Normal	GA	ND			
IZ-0003	Input Zone	Trbl.	None	Normal	GA	ND			
IZ-0004	Input Zone	Mon.	None	Normal	GA	ND			
IZ-0005	Input Zone	Alarm	None	Normal	GA	ND			
IZ-0006	Input Zone	Alarm	None	Normal	GA	ND			
IZ-0007	Input Zone	Alarm	None	Normal	GA	ND			
IZ-0008	Input Zone	Alarm	None	Normal	GA	ND			
IZ-0009	Input Zone	Alarm	None	Normal	GA	ND			
IZ-0010	Input Zone	Alarm	None	Normal	GA	ND			
IZ-0011	Input Zone	Alarm	None	Normal	GA	ND			

Select items to add

Inputs | Signal | Relay | Display | Switches | UDACT Grp | Digitized Msgs

Type	Node Tag	CPU	L...	Addr	Device	Priority	F1	F2	F3	Tag
Signal	Node 1	0	0	0	NAC OptCkt					Base Signal
Signal	Node 1	0	0	1	NAC OptCkt					Base Signal
Signal	Node 1	0	0	2	NAC OptCkt					Base Signal
Signal	Node 1	0	0	3	NAC OptCkt					Base Signal
Signal	Node 1	65	2	0.1.1	25 Watt ClassD					
Signal	Node 1	65	2	0.1.2	25 Watt ClassD					
Signal	Node 1	65	2	0.1.3	25 Watt ClassD					
Signal	Node 1	65	2	0.1.4	25 Watt ClassD					
Signal	Node 1	65	2	0.2.1	25 Watt ClassD					
Signal	Node 1	65	2	0.2.2	25 Watt ClassD					
Signal	Node 1	65	2	0.2.3	50 Watt ClassD		A...			
Signal	Node 1	65	2	0.3.1	25 Watt ClassD					
Signal	Node 1	65	2	0.3.2	75 Watt ClassD		A...			
Signal	Node 1	65	2	0.4.1	75 Watt ClassD		A...			
Signal	Node 1	65	2	0.4.4	25 Watt ClassD					

Add Close

9. Assign 3 LED display points to indicate the Alarm statuses of the 3 input zones.

Figure 124 Assign LEDs

Idx	Led	Sw	Grp	Type	Assignment
0	0	0	39	Ipt Zone	Alarm Stat
1	2	1	41	Ipt Zone	Alarm Stat
2	4	2	43	Ipt Zone	Alarm Stat
3	6	3		<unassigned>	
4	8	4		<unassigned>	
5	10	5		<unassigned>	
6	12	6		<unassigned>	
7	14	7		<unassigned>	
8	16	8		<unassigned>	
9	18	9		<unassigned>	
10	20	10		<unassigned>	
11	22	11		<unassigned>	
12	0	0		<unassigned>	
13	2	1		<unassigned>	
14	4	2		<unassigned>	
15	6	3		<unassigned>	
16	8	4		<unassigned>	
17	10	5		<unassigned>	
18	12	6		<unassigned>	
19	14	7		<unassigned>	
20	16	8		<unassigned>	
21	18	9		<unassigned>	
22	20	10		<unassigned>	
23	22	11		<unassigned>	

10. Correlate those display points to their respective input zones as shown below.

Figure 125 Correlate LEDs to Input Zones

Idx	Led	Sw	Grp	Type	Assignment	Node Group	Priority	F1	F2	F3	Tag
0	0	0	39	Ipt Zone	Alarm Stat						
1	2	1	41	Ipt Zone	Alarm Stat						
2	4	2	43	Ipt Zone	Alarm Stat						
3	6	3		<unassigned>							
4	8	4		<unassigned>							
5	10	5		<unassigned>							
6	12	6		<unassigned>							

Type	Node Tag	CPU	L...	Addr	Device	Priority	F1	F2	F3	Tag
Alarm	Node 1			1.1	Input Zone	Normal	GA	ND		Floor 1
Alarm	Node 1			5.1	Input Zone	Normal	GA	ND		Floor 2
Alarm	Node 1			6.1	Input Zone	Normal	GA	ND		Floor 3
Alarm	Node 1			7.1	Input Zone	Normal	GA	ND		
Alarm	Node 1			8.1	Input Zone	Normal				
Alarm	Node 1			9.1	Input Zone	Normal				
Alarm	Node 1			10.1	Input Zone	Normal				
Alarm	Node 1			11.1	Input Zone	Normal				
Alarm	Node 1			12.1	Input Zone	Normal				
Alarm	Node 1			13.1	Input Zone	Normal				
Alarm	Node 2			1.1	Input Zone	Normal				Alarm Queue

11. Validate the job by going to the job menu and selecting **Validate**.

Warranty and Warning Information

WARNING!

Please read this document **CAREFULLY**, as it contains important warnings, life-safety, and practical information about all products manufactured by the Mircom Group of Companies, including Mircom and Secutron branded products, which shall include without limitation all fire alarm, nurse call, building automation and access control and card access products (hereinafter individually or collectively, as applicable, referred to as “**Mircom System**”).

NOTE TO ALL READERS:

1. **Nature of Warnings.** The within warnings are communicated to the reader out of an abundance of caution and create no legal obligation for Mircom Group of Companies, whatsoever. Without limiting the generality of the foregoing, this document shall NOT be construed as in any way altering the rights and obligations of the parties, governed by the legal documents that apply in any given circumstance.
2. **Application.** The warnings contained in this document apply to all Mircom System and shall be read in conjunction with:
 - a. the product manual for the specific Mircom System that applies in given circumstances;
 - b. legal documents that apply to the purchase and sale of a Mircom System, which may include the company’s standard terms and conditions and warranty statements;
 - c. other information about the Mircom System or the parties’ rights and obligations as may be application to a given circumstance.
3. **Security and Insurance.** Regardless of its capabilities, no Mircom System is a substitute for property or life insurance. Nor is the system a substitute for property owners, renters, or other occupants to act prudently to prevent or minimize the harmful effects of an emergency situation. Building automation systems produced by the Mircom Group of Companies are not to be used as a fire, alarm, or life-safety system.

NOTE TO INSTALLERS:

All Mircom Systems have been carefully designed to be as effective as possible. However, there are circumstances where they may not provide protection. Some reasons for system failure include the following. As the only individual in contact with system users, please bring each item in this warning to the attention of the users of this Mircom System. Failure to properly inform system end-users of the circumstances in which the system might fail may result in over-reliance upon the system. As a result, it is imperative that you properly inform each customer for whom you install the system of the possible forms of failure:

4. **Inadequate Installation.** All Mircom Systems must be installed in accordance with all the applicable codes and standards in order to provide adequate protection. National standards require an inspection and approval to be conducted by the local authority having jurisdiction following the initial installation of the system and following any changes to the system. Such inspections ensure installation has been carried out properly.
5. **Inadequate Testing.** Most issues and/or problems that would prevent a Mircom System alarm from operating as intended, can be identified through regular testing and maintenance. The complete system should be tested by the local authority having jurisdiction immediately after a fire, storm, earthquake, accident, or any kind of construction activity inside or outside

the premises. The testing should include all sensing devices, keypads, consoles, alarm indicating devices and any other operational devices that are part of the system.

NOTE TO USERS:

All Mircom Systems have been carefully designed to be as effective as possible. However, there are circumstances where they may not provide protection. Some reasons for system failure include the following. The end user can minimize the occurrence of any of the following by proper training, testing and maintenance of the Mircom Systems:

6. **Inadequate Testing and Maintenance.** It is imperative that the systems be periodically tested and subjected to preventative maintenance. Best practices, local codes, applicable laws and industry regulations, and any local authority having jurisdiction to do so, determine the frequency and type of testing that is required at a minimum. Mircom System may not function properly, and the occurrence of other system failures identified below may not be minimized, if the periodic testing and maintenance of Mircom Systems is not completed with diligence and as required.
7. **Improper Operation.** It is important that all system users be trained in the correct operation of the alarm system and that they know how to respond when the system indicates an alarm. A Mircom System may not function as intended during an emergency situation where the user is unable to operate a panic or emergency switch by reason of permanent or temporary physical disability, inability to reach the device in time, unfamiliarity with the correct operation, or related circumstances.
8. **Insufficient Time.** There may be circumstances when a Mircom System will operate as intended, yet the occupants will not be protected from the emergency due to their inability to respond to the warnings in a timely manner. If the system is monitored, the response may not occur in time enough to protect the occupants or their belongings.
9. **Carelessness or Safety Hazards.** Moreover, smoke detectors may not provide timely warning of fires caused by carelessness or safety hazards such as smoking in bed, violent explosions, escaping gas, improper storage of flammable materials, overloaded electrical circuits or children playing with matches or arson.
10. **Power Failure.** Some Mircom System components require adequate electrical power supply to operate. Examples include: smoke detectors, beacons, HVAC, and lighting controllers. If a device operates only by AC power, any interruption, however brief, will render that device inoperative while it does not have power. Power interruptions of any length are often accompanied by voltage fluctuations which may damage Mircom Systems or other electronic equipment. After a power interruption has occurred, immediately conduct a complete system test to ensure that the system operates as intended.
11. **Battery Failure.** If the Mircom System or any device connected to the system operates from batteries it is possible for the batteries to fail. Even if the batteries have not failed, they must be fully charged, in good condition, and installed correctly. Some Mircom Systems use replaceable batteries, which have a limited life-span. The expected battery life is variable and in part dependent on the device environment, usage and type. Ambient conditions such as high humidity, high or low temperatures, or large temperature fluctuations may reduce the expected battery life. Moreover, some Mircom Systems do not have a battery monitor that would alert the user in the event that the battery is nearing its end of life. Regular testing and replacements are vital for ensuring that the batteries function as expected, whether or not a device has a low-battery monitor.
12. **Physical Obstructions.** Motion sensors that are part of a Mircom System must be kept clear of any obstacles which impede the sensors' ability to detect movement. Signals being communicated by a Mircom System may not reach the receiver if an item (such as metal, water, or concrete) is placed on or near the radio path. Deliberate jamming or other inadvertent radio signal interference can also negatively affect system operation.

13. **Wireless Devices Placement Proximity.** Moreover all wireless devices must be a minimum and maximum distance away from large metal objects, such as refrigerators. As the end user, you are required to consult the specific Mircom System manual and application guide for any maximum distances required between devices and suggested placement of wireless devices for optimal functioning.
14. **Failure to Trigger Sensors.** Moreover, Mircom Systems may fail to operate as intended if, motion, heat, carbon monoxide (CO) and/or smoke sensors, are not triggered.
 - a. Sensors in a fire system may fail to be triggered when the fire is in a chimney, walls, roof, or on the other side of closed doors. Smoke and heat detectors may not detect smoke or heat from fires on another level of the residence or building. In this situation the control panel may not alert occupants of a fire.
 - b. Sensors in a nurse call system may fail to be triggered when movement is occurring outside of the motion sensors' range. For example, if movement is occurring on the other side of closed doors or on another level of the residence or building the motion detector may not be triggered. In this situation the central controller may not register an alarm signal.
15. **Interference with Audible Notification Appliances.** Audible notification appliances may be interfered with by other noise sources such as stereos, radios, televisions, air conditioners, appliances, or passing traffic. Audible notification appliances, however loud, may not be heard by a hearing-impaired person.
16. **Other Impairments.** Alarm notification appliances such as sirens, bells, horns, or strobes may not warn or waken a sleeping occupant if there is an intervening wall or door. It is less likely that the occupants will be alerted or awakened when notification appliances are located on a different level of the residence or premise.
17. **Software Malfunction.** Most Mircom Systems contain software. No warranties are provided as to the software components of any products or stand-alone software products within a Mircom System. For a full statement of the warranties and exclusions and limitations of liability please refer to the company's standard Terms and Conditions and Warranties.
18. **Telephone Line/Network Malfunction.** Telephone service can cause system failure where telephone lines/networks are relied upon by a Mircom System. Alarms and information coming from a Mircom System may not be transmitted if a phone line/network is out of service or busy for a certain period of time. Alarms and information may not be transmitted where telephone lines/networks have been compromised by criminal tampering, local construction, storms or earthquakes.
19. **Component Failure.** Although every effort has been made to make this Mircom System as reliable as possible, the system may fail to function as intended due to the failure of a component.
20. **Integrated Products.** Mircom System might not function as intended if it is connected to a non-Mircom product or to a Mircom product that is deemed non-compatible with a particular Mircom System. A list of compatible products can be requested and obtained.
21. A Mircom System's Auto Configuration feature is intended to assign the Alarm process type to all inputs and to provide an initial set up by detecting connected devices and generates a basic job configuration upon the initial installation of the Mircom System. Mircom makes no representations, warranties or guarantees regarding the accuracy or suitability of the basic job configuration generated upon installation, for any specific site requirements.

The end user shall be solely and exclusively responsible to thoroughly review the basic job generated by the auto configuration feature upon initial installation and to implement necessary adjustments and modifications to customize the job configuration in accordance with the functional and/or technical requirements of the site. Mircom expressly disclaims any responsibility or liability for any failure, malfunction or defective operation of a Mircom System and any associated components, resulting from the end user's failure to customize or adjust the job configuration accordingly.

By installing and utilizing the Mircom System, the user acknowledges and agrees that Mircom shall not be liable for any claims, losses, damages, or defects arising from the failure of the user or installer and those for whom it is responsible at law, to customize the basic job configuration generated on the initial set-up in accordance with the requirements of the site.

Warranty

Purchase of all Mircom products is governed by:

<https://www.mircom.com/product-warranty>

<https://www.mircom.com/purchase-terms-and-conditions>

<https://www.mircom.com/software-license-terms-and-conditions>



© Mircom 2025
Printed in Canada
Subject to change without prior notice

www.mircom.com

CANADA - Main Office
25 Interchange Way
Vaughan, ON L4K 5W3
Tel: (905) 660-4655
(888) 660-4655
Fax: (905) 660-4113

U.S.A
4575 Witmer Industrial Estates
Niagara Falls, NY 14305
Tel: (905) 660-4655
(888) 660-4655
Fax: (905) 660-4113