

INSTALLATION AND MAINTENANCE INSTRUCTIONS MIX-4040-M MULTI-INPUT MODULE

ABOUT THIS MANUAL

This manual is included as a quick reference for installation. For further information on the use of this device with a FACP, please refer to the panel's manual.

Note: This manual should be left with the owner or operator of this equipment.

DESCRIPTION

The MIX-4040-M multi-input module can be configured to support either 6 class A or 12 class B inputs. When configured for class A operation, the module provides an internal EOL resistor. When configured for class B operation, the module can monitor 12 independent input circuits while using only one module address. All circuits are power limited and supervised.

The MIX-4040-M is compatible with FX-400, FX-401 and FleX-Net™ FX-4000 fire alarm control panels and is designed to meet UL 864, 10th Edition and ULC S527, 4th Edition requirements for devices.

The address of each module is set using the MIX-4090 programmer tool and up to 240 MIX-4000 series devices may be installed on a single loop (limited by standby and alarm current). The module has LED indicators for each input to signal alarm (red) or trouble (yellow). A green LED shows SLC communication status and finally, two yellow LEDs indicate if a short circuit has been isolated on either side of the SLC connection.

Accessories

MP-302	22 kΩ EOL resistor
MP-300R	EOL resistor plate
BB-4002R	Back Box and Red Door for 1 or 2 MIX-4000-M Series Modules
BB-4006R	Back Box and Red Door for up to 6 MIX-4000-M Series Modules

FIGURE 1: MODEL FRONT AND SIDE VIEW

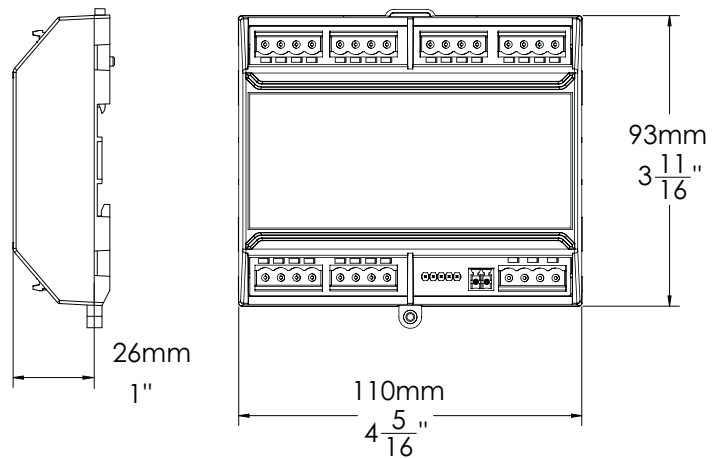

SPECIFICATIONS

Normal Operating Voltage:	UL tested 15 to 30VDC UL rated 17.64 to 27.3 VDC
Alarm Current:	8.3 mA
Standby Current:	4.0 mA max.
EOL Resistance:	22 kΩ
Max Input Wiring Resistance:	150 Ω total
Temperature Range:	0°C to 49°C (32°F to 120°F)
Humidity Range:	10% to 93% non-condensing
Dimensions:	110 mm x 93mm (4 5/16 x 3 11/16 in)
Terminal wire gauge:	12-22 AWG

KEY COMPONENTS

FIGURE 2: MULTI-INPUT MODULE ASSEMBLY COMPONENTS

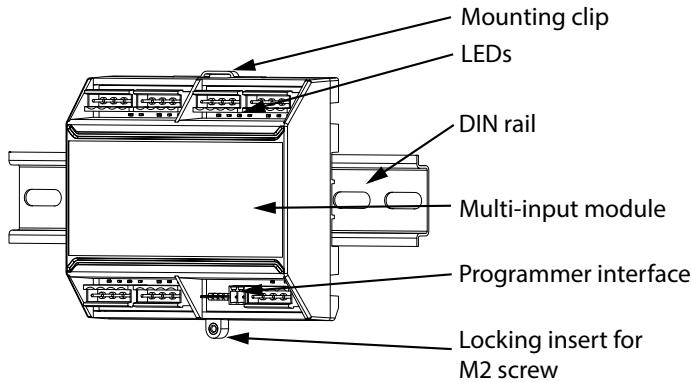

The MIX-4040-M multi-input module as shown in figure 2 is designed to fit on a DIN rail. The M2 screw can be used to lock its position.

Note: This device must be installed as per applicable requirements of the authorities having jurisdiction.

MOUNTING

Units in the multi module series can be mounted on a top-hat style 35mm wide DIN rail included in the MGC listed enclosures:

- BB-4002R for 1 or 2 modules (see document LT-6736) or equivalent Listed enclosure of the same size or larger (see document LT-6749)
 - BB-4006R for up to 6 modules (see document LT-6736) or equivalent Listed enclosure of the same size or larger (see document LT-6749)
1. Hook the multi module device onto the bottom of the DIN rail with three teeth.
 2. Push the mounting clip upward with a flat screwdriver.
 3. Push the multi module device onto the DIN rail and release the clip.

FIGURE 3: MOUNTING DIAGRAM

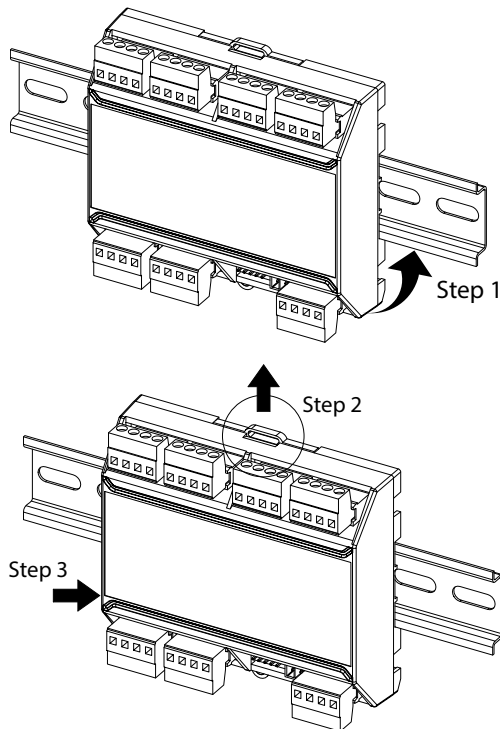

WIRING

Before installing this device, seek guidance from the compatible control panel instructions for the device's operation modes and the configuration requirements. It is recommended to disconnect the SLC line before performing installation or service.

FIGURE 4: DEVICE CONNECTION – CLASS A/B WIRING

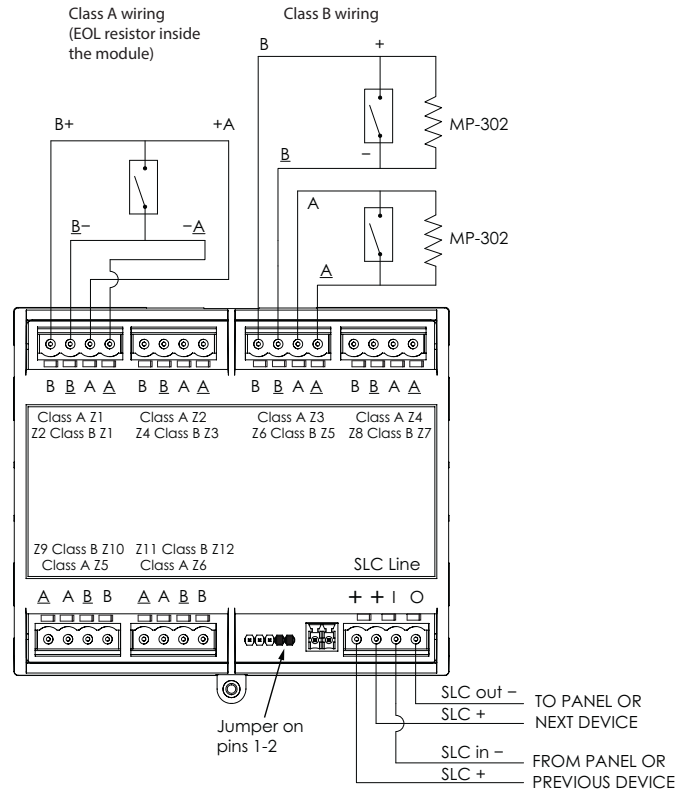

Note: A factory-installed jumper is required between pins 1 and 2 of the J1 connector (next to the programmer connector).

All connections to field wiring are done with plug-in terminal blocks.

All wiring is power limited and supervised.

Use the information in this document to determine the total current draw of the devices. In all cases, the installer should consider the voltage drop to ensure that the last device on the circuit operates within its rated voltage. Please consult the FACP documentation for more information.

RELATED DOCUMENTS

- LT-6736 BB-4002R and BB-4006R Installation Instructions
- LT-6749 MGC-4000-BR DIN Rail Kit Installation Instructions