

# 1 Mount the Enclosure

**Attention:** The 22" Touch Screen enclosure is heavy (80 lbs or 37 kg). Never attempt to lift this product by yourself. At least two people should lift it together.

The enclosure mounts on the wall. Mount the enclosure right-side up (the Mircom logo on the door is in the lower right corner).

**You need:**  
4 fasteners appropriate for the wall that you are mounting the enclosure on.

1. Find a suitable location for the enclosure. The wall must be able to support a weight of 80 lbs (37 kg).
2. Mark the back mounting locations of the two top screws. Ensure that at least one screw is over a wall stud.
3. Place the fasteners halfway into the wall in the two top keyhole locations and wall stud.
4. Place the enclosure onto the fasteners, then lower it so that the fasteners fit in the narrow part of the keyholes.
5. Screw the other fasteners into the remaining holes.
6. Tighten all fasteners into place.

### Installation Prerequisites

- Verify that the building telephone infrastructure is operational. When wiring an NSL installation it may be necessary to check each resident's line.
- Ensure there is a provision for a ground circuit. The Telephone Access System assembly must be grounded by a qualified electrician. An improperly grounded unit can result in equipment malfunction and void the warranty.
- Use the latest Telephone Access System controller firmware. Mircom periodically updates panel firmware and Configurator Software to add features and correct any minor inconsistencies. For information about the latest firmware or software visit the 'Manuals and Downloads' section of the Mircom website at [www.mircom.com](http://www.mircom.com)

# 2 AC Door Strike or Maglock

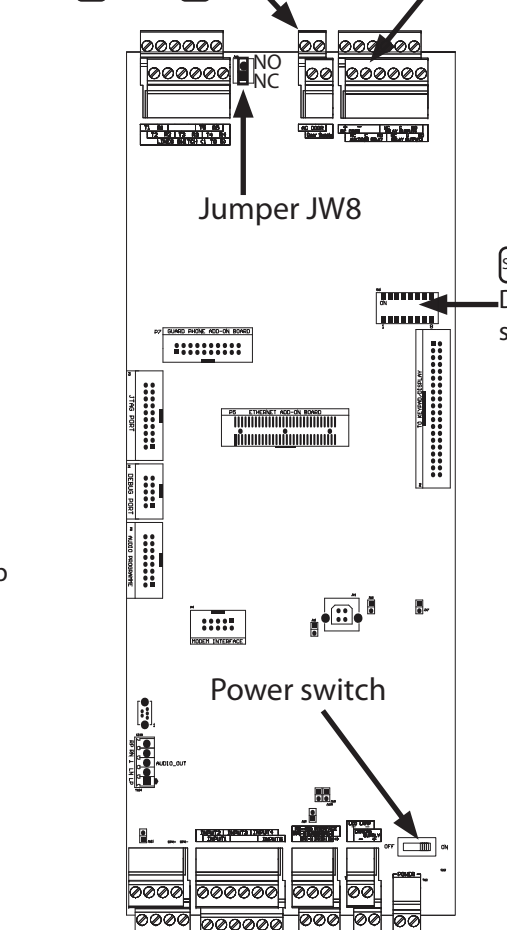

**Warning:** Turn the power off before wiring.  
**Install all power supplies outside the enclosure.**

**Wiring Requirements**  
Unless specified otherwise, all wiring is a maximum length of 1000 ft (304.8 m).

**RS-485:** Maximum total length: 4000 ft (1219.2 m)  
Use twisted shielded pair.

**Door Strike:** The door strike power supply depends on the door strike power requirements.

### Maximum Power Supply Wire Distances

Gauge	Distance
16	125 ft (38.1 m)
14	200 ft (60.96 m)
12	320 ft (97.536 m)
10	500 ft (152.4 m)

# 3 DC Door Strike (Output 1)

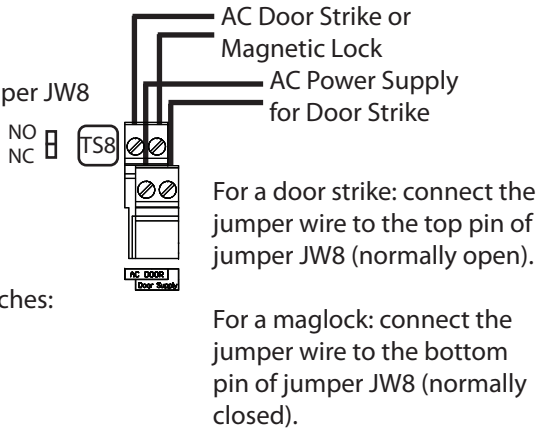

# 4 Auxiliary Door (Output 2)

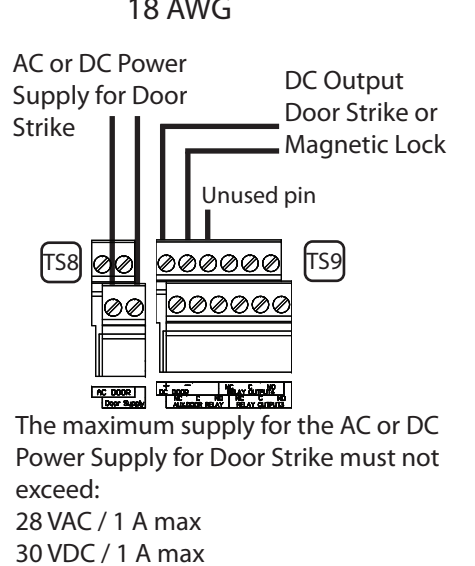

# 5 DIP Switch Settings for RS-485 Address

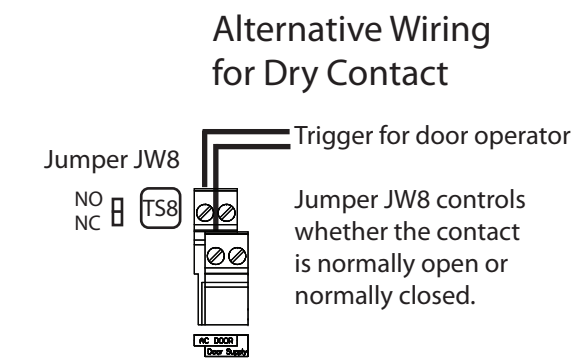
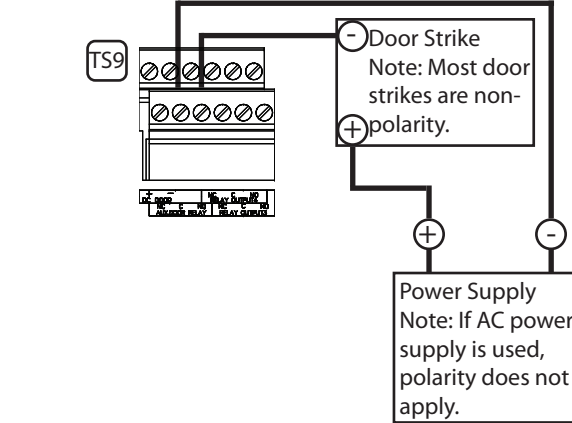

### Outputs 2-4

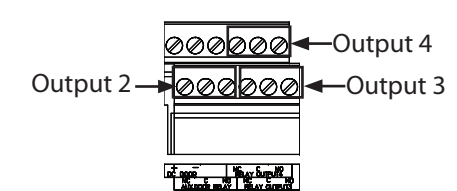

Contact ratings for outputs 2-4:  
125 VAC / 2 A  
30 VDC / 1 A

# 5 DIP Switch Settings for RS-485 Address



Each Touch Screen must have a unique RS-485 address. Use DIP switches 1-6 to set the RS-485 network address. See LT-969 for details. Leave DIP switch 7 on.

Warning: Turn the power off before wiring.

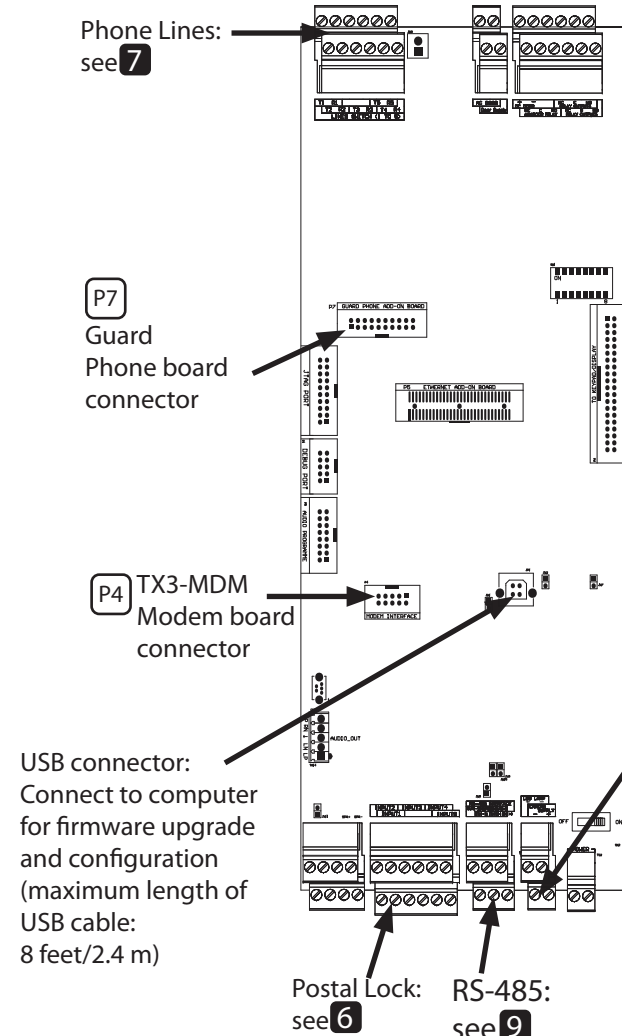

### 7 Phone Lines

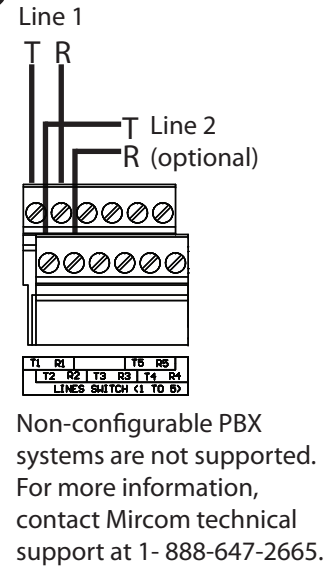

### 8 Camera Supply

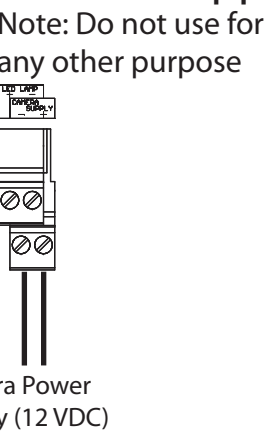

### 6 Postal Lock (Input 1) Fire Alarm Override (Input 2) Door Contact (Input 3) 22 AWG

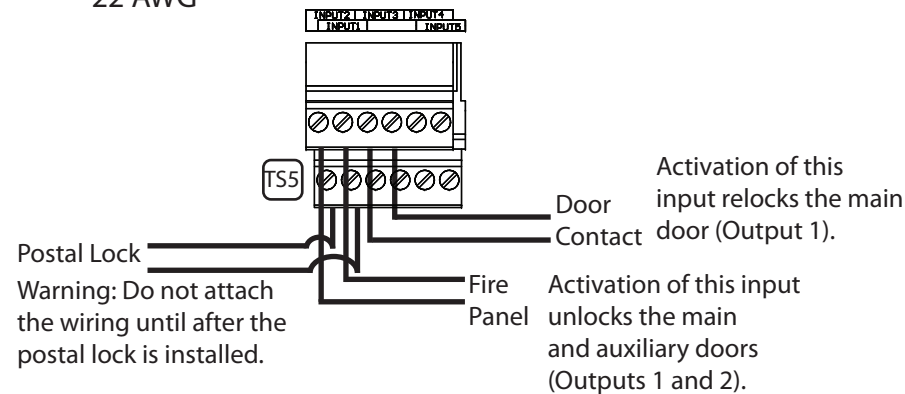

### 9 RS-485

Maximum total length: 4000 ft (1219.2 m) for 22 AWG  
Use twisted shielded pair. See LT-996 for complete details.

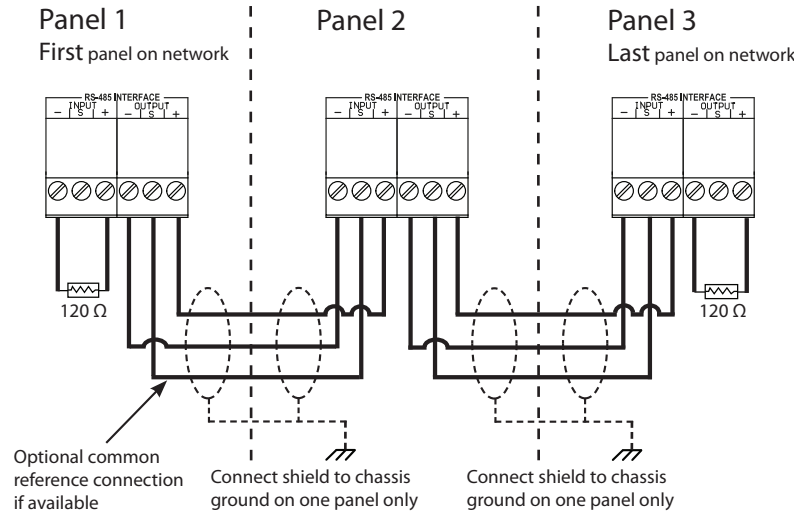

### 10 Ground and Power

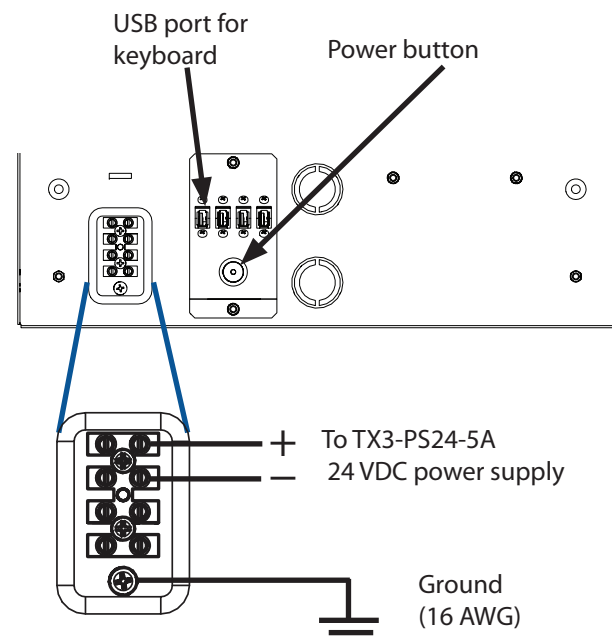

### 11 Mount the TX3-PS24-5A 24 VDC, 156 W Power Supply

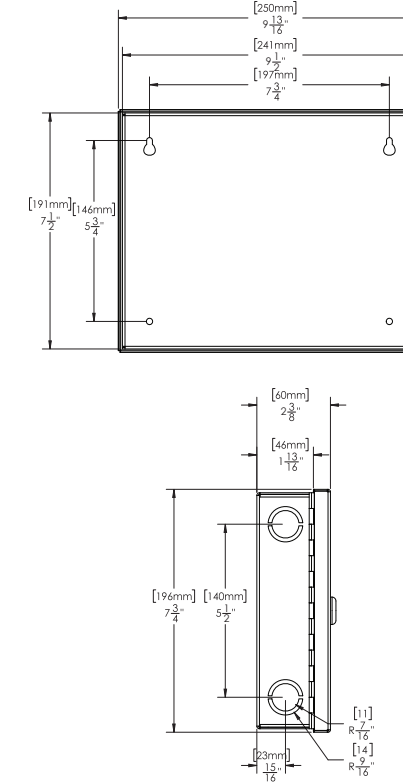

To surface mount the power supply enclosure:  
You need 4 fasteners appropriate for the wall that you are mounting the enclosure on.

1. Find a suitable location for the power supply enclosure, such as over a wall stud.
2. Using the enclosure as a template, mark the two top mounting hole locations. Ensure that at least one side is over a wall stud.
3. Remove the enclosure and place two wall fasteners halfway into the marked hole locations.
4. Place the enclosure onto the fasteners and lower it so that the fasteners fit in the narrow part of the keyholes.
5. Screw the other two fasteners into the two remaining holes.
6. Tighten all four fasteners into place.

Note: The enclosure can also be mounted directly onto the drywall using anchors.

### 12 Connect the Power

1. Set the voltage selectable switch on the power supply to the appropriate voltage. The voltage selectable switch can be set to either 115 V or 230 V.
2. Connect the load power supply wires to the Touch Screen terminal screws as shown in step 10.
3. Connect the other end of the load power supply wires the **Load** terminals.
4. Connect the building power supply wires to the **Line** terminals as shown below.
5. Turn the power on by pressing the power button.

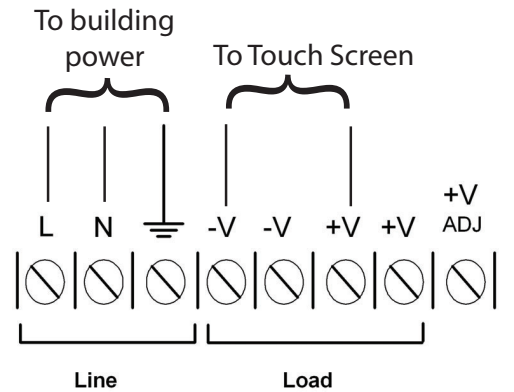

**WARNING**

To ensure the security of occupants, change the level 3 passcode from its default setting. See LT-995 on [mircom.com](http://mircom.com) for details.

**Mircom**  
<http://www.mircom.com>  
CANADA - Main Office  
25 Interchange Way  
Vaughan, ON L4K 5W3  
Tel: (888) 647-2665  
(905) 660-4655

U.S.A  
4575 Witmer Industrial Estates  
Niagara Falls, NY 14305  
Tel: (888) 647-2665  
TECHNICAL SUPPORT  
Tel: 1-888-647-2665