

1 Mount the Enclosure

Attention: The 22" Touch Screen enclosure is heavy (80 lbs or 37 kg). Never attempt to lift this product by yourself. At least two people should lift it together.

The enclosure right mounts on the wall. Mount the enclosure right-side up (the Mircom logo on the door is in the lower right corner).

- You need:**
6 fasteners appropriate for the wall that you are mounting the enclosure on.
1. Find a suitable location for the enclosure. You can mount the enclosure using the keyholes on the back, or the knockouts on the side, or both.
 2. Trace an opening in the wall for the enclosure with one side aligned with a wall stud.
 3. Cut an opening in the wall 3/32" (3 mm) larger than the tracing.
 4. Insert the enclosure into the wall cutout, and using the side of the enclosure as a template mark the hole mounting locations.
 5. If you are using the keyholes, remove the enclosure and place 2 fasteners halfway into the wall into the two top keyhole locations.
 6. Place the enclosure onto the top fasteners, then lower it so that the fasteners fit in the narrow part of the keyholes.
 7. Screw the other fasteners into the remaining holes.
 8. Tighten all fasteners into place.

Installation Prerequisites

- Verify that the building telephone infrastructure is operational. When wiring an NSL installation it may be necessary to check each resident's line.
- Ensure there is a provision for a ground circuit. The Telephone Access System assembly must be grounded by a qualified electrician. An improperly grounded unit can result in equipment malfunction and void the warranty.
- Use the latest Telephone Access System controller firmware. Mircom periodically updates panel firmware and Configurator Software to add features and correct any minor inconsistencies. For information about the latest firmware or software visit the 'Manuals and Downloads' section of the Mircom website at www.mircom.com

AC or DC Door Strikes: see 2 and 3
Auxiliary Door Strike: see 4

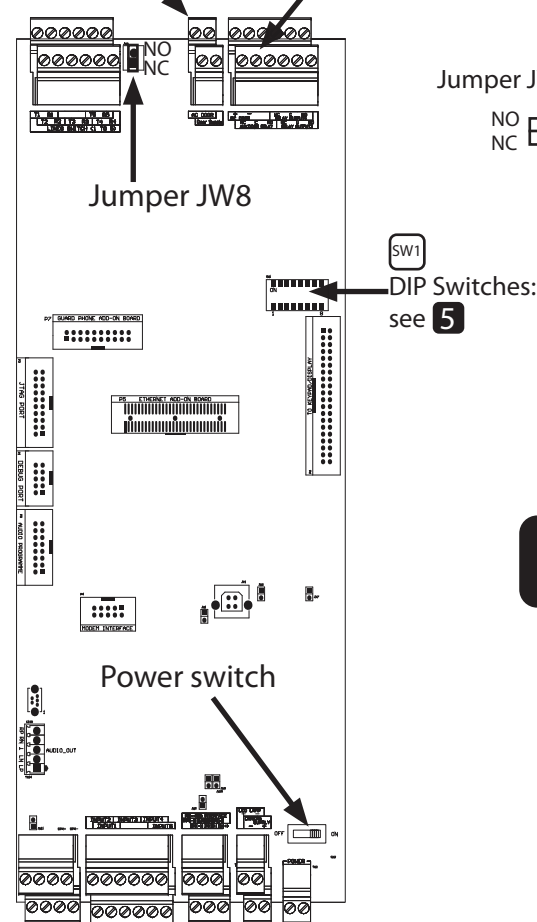

Warning: Turn the power off before wiring.
Install all power supplies outside the enclosure.

Wiring Requirements

Unless specified otherwise, all wiring is a maximum length of 1000 ft (304.8 m).

RS-485: Maximum total length: 4000 ft (1219.2 m)
Use twisted shielded pair.

Door Strike: The door strike power supply depends on the door strike power requirements.

Maximum Power Supply Wire Distances

| Gauge | Distance |
|-------|-------------------|
| 16 | 125 ft (38.1 m) |
| 14 | 200 ft (60.96 m) |
| 12 | 320 ft (97.536 m) |
| 10 | 500 ft (152.4 m) |

2 AC Door Strike or Maglock 18 AWG

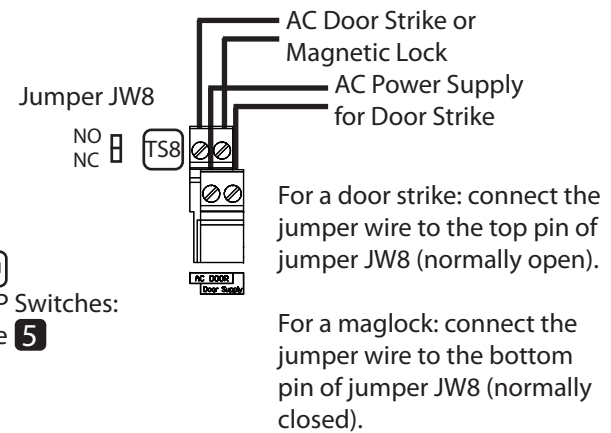

3 DC Door Strike (Output 1) 18 AWG

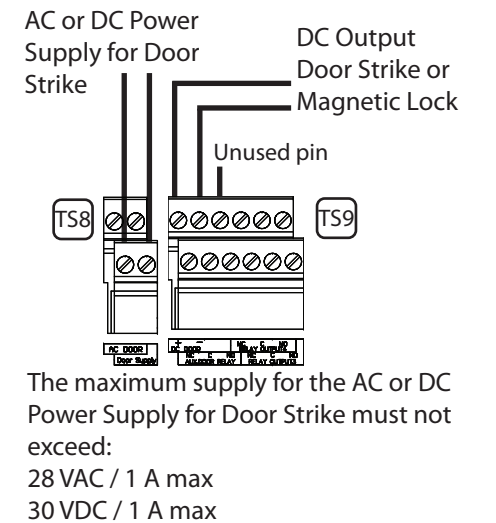

4 Auxiliary Door (Output 2) 18 AWG

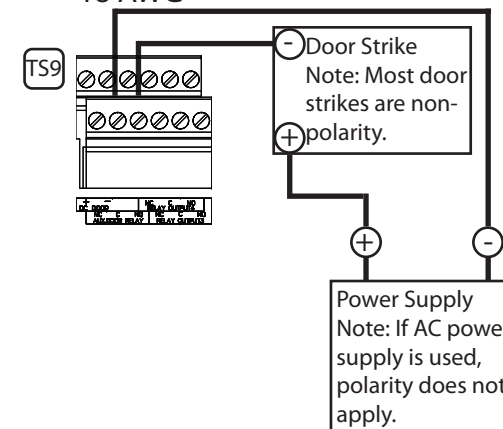

Alternative Wiring for Dry Contact

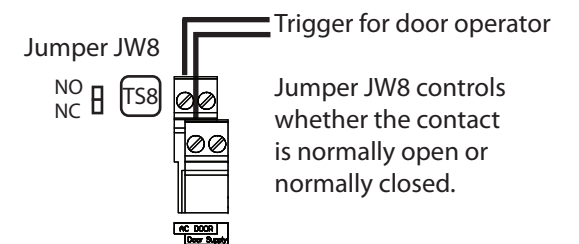

Outputs 2-4

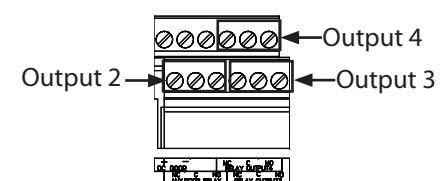

Contact ratings for outputs 2-4:
125 VAC / 2 A
30 VDC / 1 A

5 DIP Switch Settings for RS-485 Address



Each Touch Screen must have a unique RS-485 address. Use DIP switches 1-6 to set the RS-485 network address. See LT-969 for details. Leave DIP switch 7 on.

