

INSTALLATION AND MAINTENANCE INSTRUCTIONS MIX-4003-LF LOW FREQUENCY SOUNDER BASE

CAUTION / ATTENTION

DO NOT PAINT OR ALTER FACTORY APPLIED FINISH IN ANY WAY
 NE PAS PEINDRE OU MODIFIER LA FINITION ORIGINALE

ABOUT THIS MANUAL

This manual is included as a quick reference for installation. For further information on the use of this device with an FACP, please refer to the panel's manual.

Note: This manual should be left with the owner or operator of this equipment.

SOUNDER BASE DESCRIPTION

The MIX-4003-LF sounder base is designed to meet UL268/ULC S529 requirements for smoke detector, UL521/ULC S530 requirements for heat detector, and UL464/ULC 525 requirements for audible notification appliances.

The MGC MIX-4003-LF provides localized alarm sounding capability for the MIX-4000 family of fire detection devices. They can be used in place of external sounders to minimize installation cost and footprint while allowing individual control of signal rate and on-off state for each device. The MIX-4003-LF must be used with a compatible MGC control panel. Operational mode and levels are selected at the Fire alarm panel through the MGC MP configuration tool.

The MIX-4003-LF produces a low frequency alarm signal at sound pressure levels shown in table 2.

FIGURE 1: MODEL FRONT AND SIDE VIEW WITH MIX-4000 SERIES DETECTOR

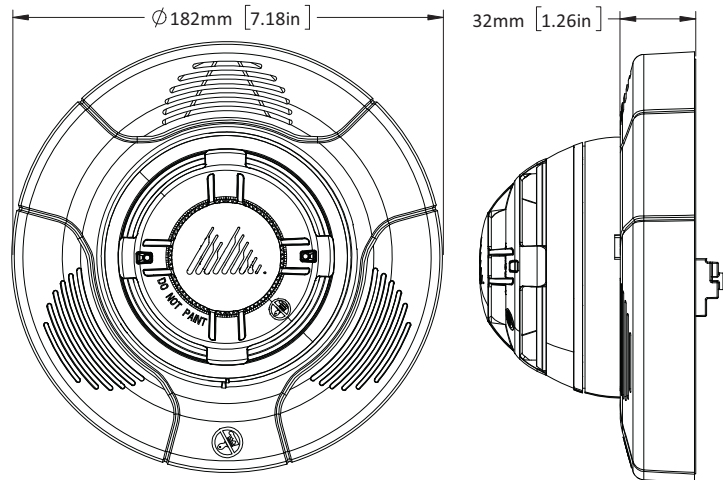

Table 1: SPECIFICATIONS

Operating Temperature	0°C to 49°C (32°F to 120°F)
Humidity Range	0% to 93%
Nominal Voltage	Regulated 24VDC/VFWR
SLC Standby Current	1.56mA
SLC Alarm Current	2.34 mA
Base Diameter	182mm (7-3/16 in)
Base Height	32mm (1-1/4 in)
Terminal wire gauge	12-22 AWG

KEY COMPONENTS

FIGURE 2: SOUNDER BASE ASSEMBLY COMPONENTS

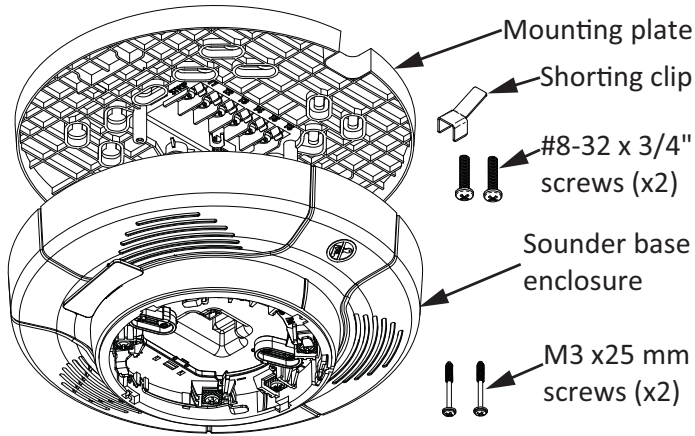
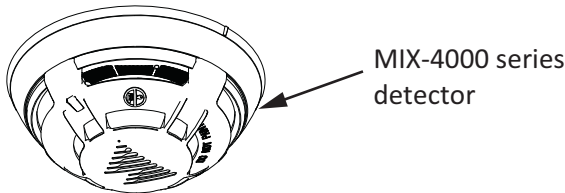

FIGURE 3: MIX-4000 SERIES DETECTOR



The mounting plate in figure 2 is mounted first on the electrical box and all wiring is done on integral screw connectors. The connections are apparent and can be visually inspected before the sounder base itself is mounted. Then, the enclosure containing the electronics, the sounder base and the detector can be plugged in and secured.

Note: This device should be installed as per applicable requirements of the authorities having jurisdiction.

WIRING

Before installing this device seek guidance from the compatible control panel instructions for the device operation modes and the configuration requirements. It is recommended to remove power from SLC and NAC lines before performing the installation.

FIGURE 4: WIRING TABS

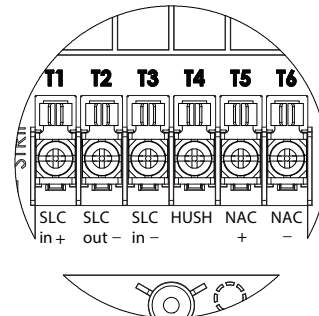
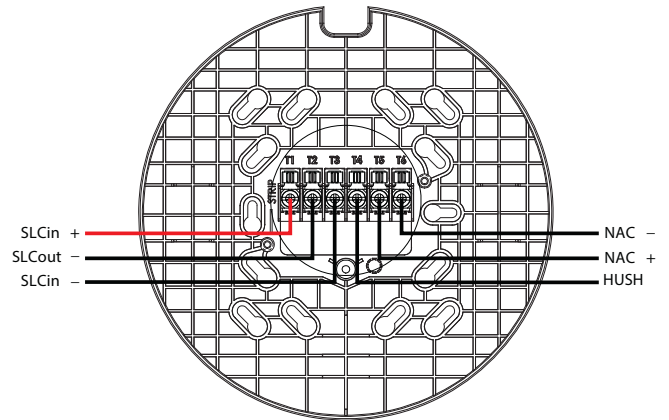

Use the information in this document to determine the total current draw of the devices. The total current draw of the devices must not exceed the NAC output capacity. In all cases, the installer should consider the voltage drop to ensure that the last device on the circuit operates within its rated voltage. Please consult fire panel installation manual for guidance on wire resistance and length. For maximum horn operating current, please refer to table 4.

Do not loop signal circuit field wires around terminals. Electrical supervision requires wire run to be broken at each end.

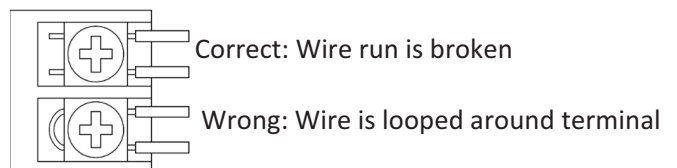
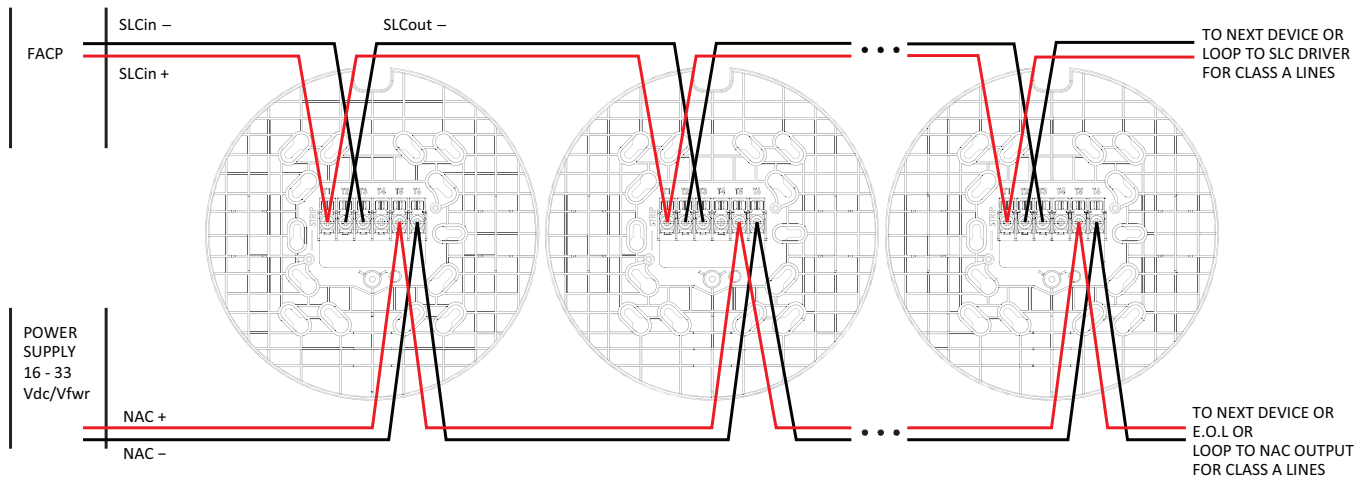

FIGURE 5: DEVICE CONNECTION



Note: Wiring must be in accordance with CSA C22.1, Canadian Electrical Code, Part I, Safety Standard for Electrical Installations, section 32 and/or NFPA 70.

CAUTION

FOR SYSTEM SUPERVISION, FOR ALL TERMINAL TAPS, DO NOT USE LOOPED WIRE UNDER TERMINALS. BREAK WIRE RUN TO PROVIDE SUPERVISION OF CONNECTIONS.

ATTENTION

NE PAS UTILISER DE FILS EN BOUCLE SOUS LES BORNES. INTERROMPRE LA CONTINUITÉ DES CÂBLES POUR PERMETTRE LA SUPERVISION DES CONNEXIONS.

MOUNTING

The mounting plate is compatible with 3" by 2" single gang device boxes, 3-3/4" by 4" double gang boxes, 4" by 2" single gang utility boxes, standard 4" by 4" boxes, and standard 4" octagon boxes.

1. Attach the mounting plate to the electrical box with two mounting #8-32 x 3/4" screws.
2. Slide down the sounder base enclosure until the connection blades touch the clips on the mounting plate.
3. Secure the mounting plate with securing M3 x25 mm screws.

FIGURE 6: MOUNTING DIAGRAM

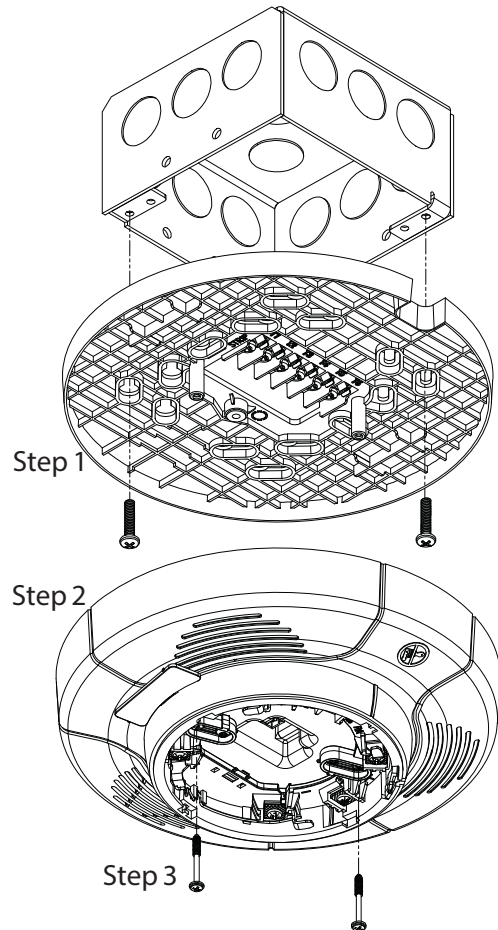

MOUNTING THE DETECTOR

If the detector type and address is required to be visible from the outside, break the address tab inside the detector base and insert it in the outer rim of the base. See figure 7.

FIGURE 7: ADDRESS TAB INSERT

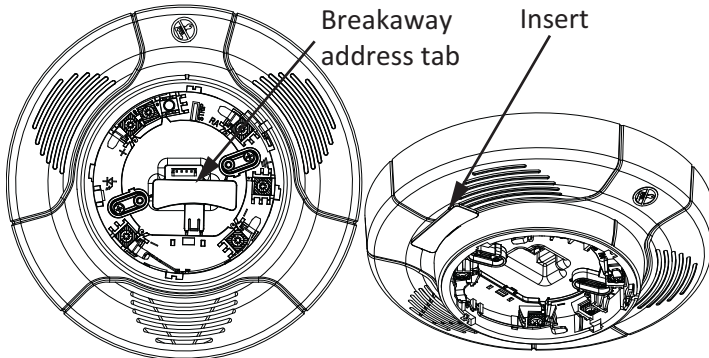

The detector can then be placed on the top base using the following steps (figure 8):

1. Position the detector centrally on its adapter base ensuring it is level.
2. Rotate clockwise applying gentle pressure. The detector will drop into its keyed location.
3. Continue to rotate clockwise a few degrees until the detector has fully engaged in the adapter base.
4. When the detector is firmly engaged, check the alignment of the raised reference marks on the detector and on the base (figure 9).

FIGURE 8: MOUNTING DETECTOR

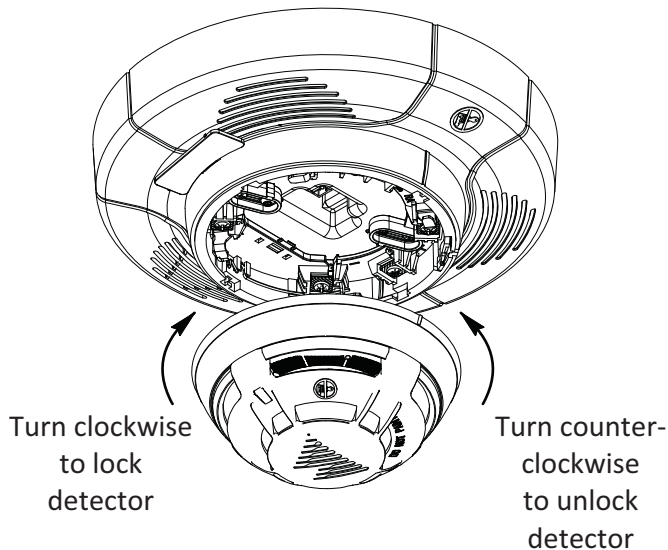
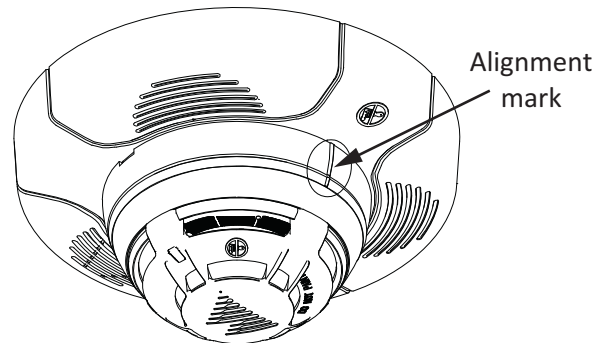

FIGURE 9: DETECTOR ALIGNMENT MARK



AUDIBLE RATINGS

Table 2: SOUND PRESSURE LEVEL OUTPUT

Sound Pattern	UL Reverberant (dBA@10ft)					
	16 VDC	Regulated 24 VDC	33 VDC	16 VFWR	Regulated 24 VFWR	33 VFWR
Temporal	76.03	76.40	75.64	76.01	75.51	76.37
Continuous	76.03	76.40	75.64	76.01	75.51	76.37
20 BPM	76.03	76.40	75.64	76.01	75.51	76.37
March	76.03	76.40	75.64	76.01	75.51	76.37

Table 3: DIRECTIONAL SOUND CHARACTERISTICS

HORIZONTAL ANGLE	VERTICAL ANGLE	OSPL (dBA)
+/- 10	+/- 5	-3
+/- 55	+/- 10	-6
+/- 90	+/- 90	-0.3

Table 4: OPERATING RMS CURRENTS (mA)

Sound Pattern	Regulated 24VDC	Regulated 24VFWR
Continuous	75	112
Temporal	76	115
20 BPM	78	116
March	76	115

The sounder base is capable of producing a variety of tone patterns, including the distinctive three-pulse temporal pattern (ANSI Temporal 3) fire alarm signal now required by NFPA 72 for commercial and residential applications and is configured in this default mode. The available tones are Continuous, ANSI Temporal 3, 20 BPM, and March. Refer to the appropriate fire alarm control panel manual for more information on selection of these tones.

NOTE: For NFPA 72 Installations, the Temporal 3 tone should be used for emergency and public mode evacuation. The use of other tone styles will be at the discretion of the local Authority Having Jurisdiction (AHJ).

Model Numbers

MIX-4003-LF 4000 SERIES LOW FREQUENCY SOUNDER BASE

Accessories

MIX-4000 SERIES DETECTORS:

MIX-4010	Non-isolated photoelectric smoke detector
MIX-4011	Non-isolated photoelectric smoke detector UL 268 Rev7
MIX-4010-ISO	Isolated photoelectric smoke detector
MIX-4011-ISO	Isolated photoelectric smoke detector UL 268 Rev7
MIX-4020	Non-isolated multi-sensor detector
MIX-4021	Non-isolated multi-sensor detector UL 268 Rev7
MIX-4020-ISO	Isolated multi-sensor detector
MIX-4021-ISO	Isolated multi-sensor detector UL 268 Rev7
MIX-4030	Non-isolated heat detector
MIX-4030-ISO	Isolated heat detector
CH-1298	NAC shorting clip

WARRANTY

Purchase of all MGC products is governed by:
<https://www.mircom.com/product-warranty>
<https://www.mircom.com/purchase-terms-and-conditions>
<https://www.mircom.com/software-license-terms-and-conditions>