

FX-2000 to FX-4000 Upgrade Guide and Installation Instructions

This guide describes how to use the four kits listed below to upgrade an FX-2000 panel to FX-4000.

- **FX-2003-UPGKIT-DF:** for upgrading FX-2003-12, FX-2003-12DS, FX-2003-6, FX-2003-6DS, FX-2003-6DS-16LED
 - RB-FX4000MN replacement main board
 - ALCN-4792MISO quad loop adder module
 - RPL-TR-063A transformer for upgrading 6 A control panels to 12 A (for FX-2003-6, FX-2003-6DS, FX-2003-6DS-16LED)
 - RPL-FX-2000-DF replacement door, inner chassis door and display kit for FX-2000 panels
- **FX-2009-UPGKIT-DF:** for upgrading FX-2009-12DS, FX-2009S-12DS
 - RB-FX4000MN replacement main board
 - ALCN-4792MISO quad loop adder module
 - RPL-FX-2009-DF replacement inner chassis door and display kit for FX-2009 panels
- **FX-2017-UPGKIT-DF:** for upgrading FX-2017-12ADS, FX-2017S-12ADS
 - RB-FX4000MN replacement main board
 - ALCN-4792MISO quad loop adder module
 - RPL-FX-2017-DF replacement door, inner chassis door and display kit for FX-2017 panels
- **FX-2000-UPGKIT:** for upgrading any of the above FX-2000 panels if no front and chassis door replacement is required
 - RB-FX4000MN replacement main board
 - ALCN-4792MISO quad loop adder module
 - RPL-TR-063A replacement transformer for upgrading 6 A control panels to 12 A

Before you begin

- Make sure you have a record of the job. After you upgrade, you will need to recreate the job.
- There must be free space for the ALCN-4792MISO quad loop adder module. The analog loop field wiring must be connected to the ALCN-4792MISO or ALCN-960MISO, not Loop 2 on the main board.
- If you plan to use MIX-4000 devices, you must also install an ALCN-960MISO quad loop adder module.
- RAX-LCD is not compatible with FleX-Net™ FX-4000. It must be replaced with RAXN-4000LCD.
- ALC-H16 hardware loop controller module, ALC-198 SLC adder, and ALC-396 SLC adder are not compatible with FleX-Net™ FX-4000. If ALC-H16 is present, contact Mircom technical support.
- FleX-Net™ FX-4000 has a limit of 7 remote annunciators, while FX-2000 has a limit of 24 remote annunciators.
- MCG recommends making a new battery calculation after the upgrade is complete.

Installation

A. Power down the panel

1. Make sure you have a record of the panel job.
2. Label all the connections so that you can reconnect them after the new hardware is installed.
3. Disconnect AC power going from the circuit breaker to the panel.
4. Disconnect the backup batteries.
5. Disconnect AC power cables from the bridge rectifier to the main board.

Install the replacement inner chassis door and display if required

Follow the instructions in the included document (LT-6667 for RPL-FX-2000-DF, LT-6778 for RPL-FX-2009-DF, and LT-6779 for RPL-FX-2017-DF).

Install the RB-FX4000MN replacement main board

Caution: To prevent damage to the boards, always hold them by the edges.

A. Remove the old board and resistor

1. Remove the adder modules and the connections to the adder modules.
2. Disconnect all field wiring, input, output, and networking harnesses from the old main board.
3. Disconnect the large resistor mounted under the board and remove the resistor (Figure 1).
This resistor is not required for the FX-4000.



Figure 1 Remove the resistor

4. Unscrew the screws or standoffs that hold the current board in place.

B. Install the new board

1. Secure the new boards with the screws or standoffs that you removed in the previous step.
2. Connect all the field wiring, input, output, and networking harnesses to the new board.
3. Reconnect the backup batteries.
4. Reconnect AC power cables from the bridge rectifier to the main board.

Note: Loop 2 on the main board is not used. Connect the analog loop field wiring to the ALCN-4792MISO or ALCN-960MISO.

Install the ALCN-4792MISO quad loop adder module

Caution: To prevent damage to the boards, always hold them by the edges.

1. Secure the new board with the included standoffs and screws as shown in Figure 2.
2. Connect all input circuits and communication cables to the new board. Follow the instructions in the included document LT-6032MP.
3. Connect the power cable to the new board last.

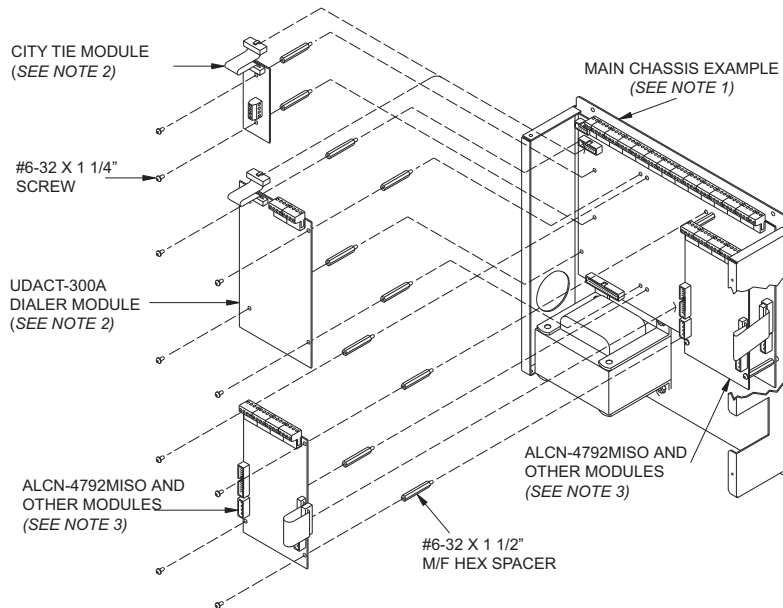

Figure 2 ALCN-4792MISO mounting locations

- Note:**
- 1) Front plate is not shown.
 - 2) Position reserved for city tie module or UDACT-300A.
 - 3) Other modules may be: FNC-2000 Network Controller Module, DM-1008A Detection Adder Module, ALCN-4792MISO Quad Loop Adder Module, ALCN-960MISO Quad Loop Adder Module, RM-1008A Relay Adder Module, SGM-1004S 4 NAC Module

Install the TR-063A Transformer on the FX-2003-6, FX-2003-6DS, FX-2003-6DS-16LED

IMPORTANT: Disconnect AC power going from the circuit breaker to the panel before you begin.

A. Remove the old transformer

1. Disconnect the old transformer by performing the following steps (refer to Figures 3 and 4 for the locations of connectors and terminals):

- Disconnect the transformer's red and blue wires from the A.C. (~) connectors on the bridge rectifier.

Note: Make a note of which terminals on the bridge rectifier the red and blue wires are connected to. They will usually be connected to the top left and bottom right corners.

- Loosen the set screws securing the transformer's brown, black, and white/blue stripe wires to the four position terminal block, and then remove the wires.

2. Remove the four nuts securing the transformer to the back plate.

B. Install the TR-063A

1. Secure the new transformer to the back plate with the four nuts provided.

2. Make the following connections:

- Connect the red and blue wires from the TR-063A to the A.C. (~) connectors on the bridge rectifier.

Note: Connect the wires to the same terminals on the bridge rectifier that the wires of the old transformer were connected to. See Figures 3 and 4.

- Insert the brown wire from the TR-063A into the 240V terminal of the four position terminal block, and then tighten the set screw.
- Insert the black wire from the TR-063A into the 120V terminal of the four position terminal block, and then tighten the set screw.
- Insert the white/blue stripe wire from the TR-063A into the neutral (N) terminal of the four position terminal block, and then tighten the set screw.

3. Connect the AC power cables from the bridge rectifier to the main board last.

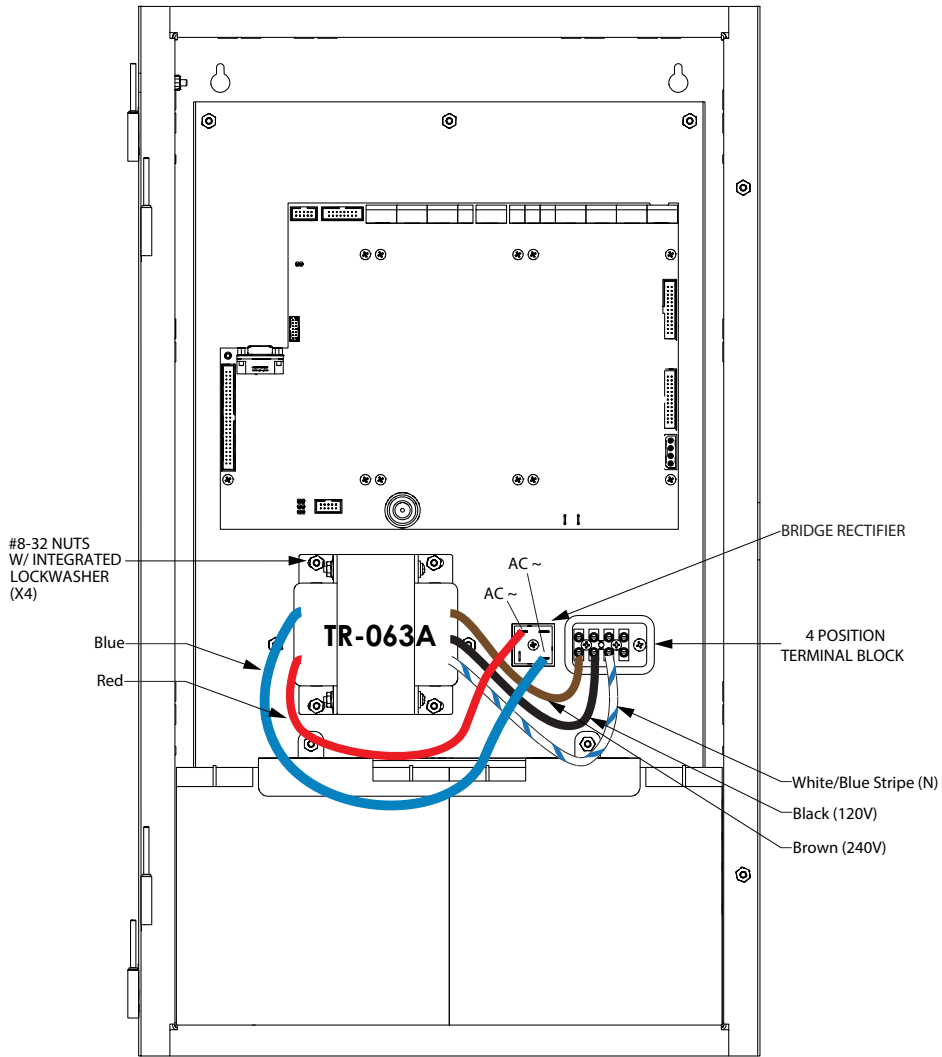

Figure 3 TR-063A in FX-2003-6DS-16LED

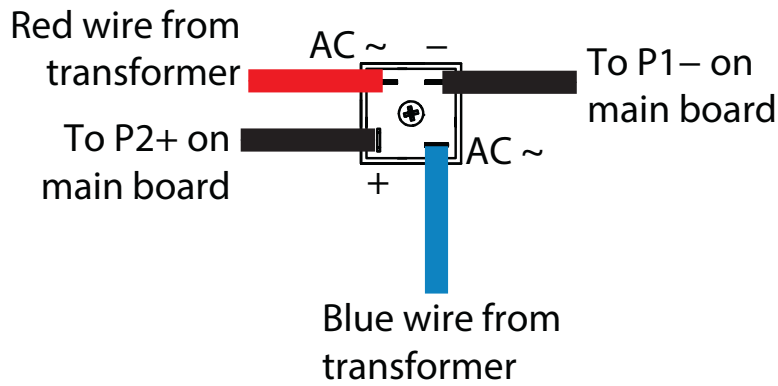

Figure 4 Close up of the bridge rectifier