

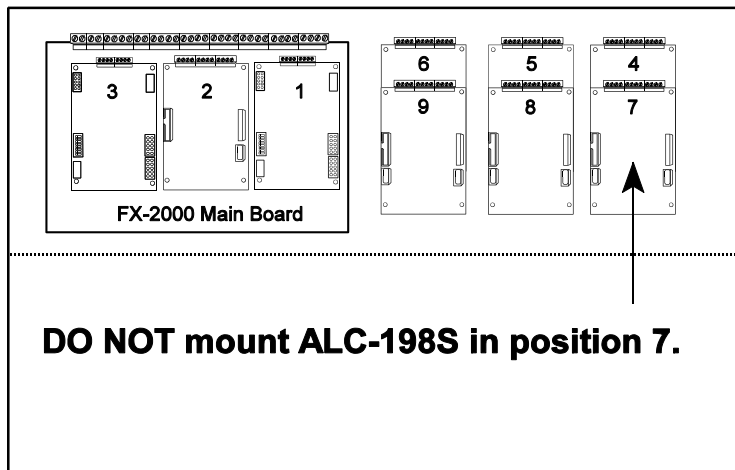

## ALC-198S SINGLE INTELLIGENT ANALOG LOOP CONTROLLER MODULE

The ALC-198S Single Intelligent Analog Loop Controller module provides a single addressable loop. It may be mounted over the main chassis of the FX-2000 Fire Alarm Panel or on any chassis which supports adder boards. Refer to the FX-2000 manual for mounting applications. The module is mounted using 4 #6 screws and (if necessary) 4 11/2" spacers. **NOTE: When using BB-5014 and BB-5008 boxes do not mount this analog loop controller module in the top position (position 7, second layer) on the far right-hand side of the backbox.**

### *BB-5008, BB-5014 Interior View*



**POWER:** The power is supplied to the board via cable from the main chassis board or from the previous loop controller module into the P1 Power IN connector. The P2 Power OUT connector is connected to the next loop controller module or other adder module. Two power cables are supplied with the module.

**RS-485:** The RS-485 cable comes attached at P3 and is connected to the main chassis board or from the previous loop controller module or other adder board. The RS-485 OUT at P4 is connected to the next loop controller module if used or left without connection.

**DIP SWITCHES:** The dip switches are used to set the address of the board. The address is binary, with the SW-1 switch as the lowest significant digit and OFF being active. For example an address of two is SW-1 ON, SW-2 OFF, and all the other dip switches SW-3 to SW-8 ON. Refer to DIP Switch settings in the FX-2000 manual for more information.

**LOOP A:** This is the addressable loop for all initiating devices. Wire the loop as shown on page 3 for Class B or page 4 for Style 7 or page 5 for Style 6 (Class A).

**JUMPERS:** A jumper is provided at JW2 for normal operation. To reset the board the jumper is left at JW2 and the pins at position JW1 are shorted momentarily.

**BDM PORT:** This connection is for Factory Use Only.

LT-863 Rev. 1  
March 2002

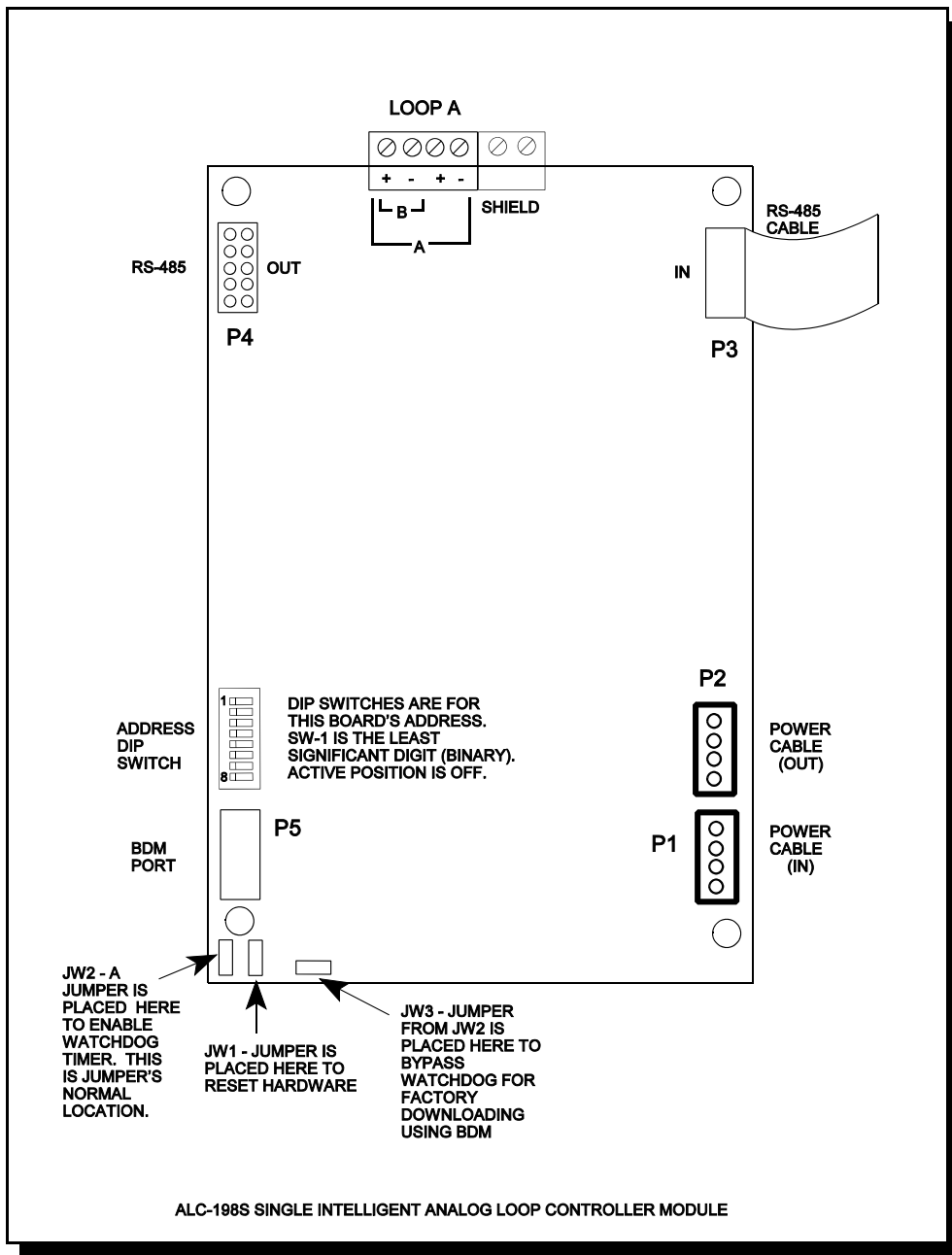

Mount the ALC-198S Single Intelligent Analog Loop Controller module as shown in the FX-2000. The module may be mounted over the main chassis board or in any position that an adder module is mounted.

### WIRING THE ADDRESSABLE LOOP

Refer to the following wiring diagrams to wire the addressable loop according to Class B, Style 7 or Style 6.

## SINGLE ADDRESSABLE LOOP CLASS B WIRING

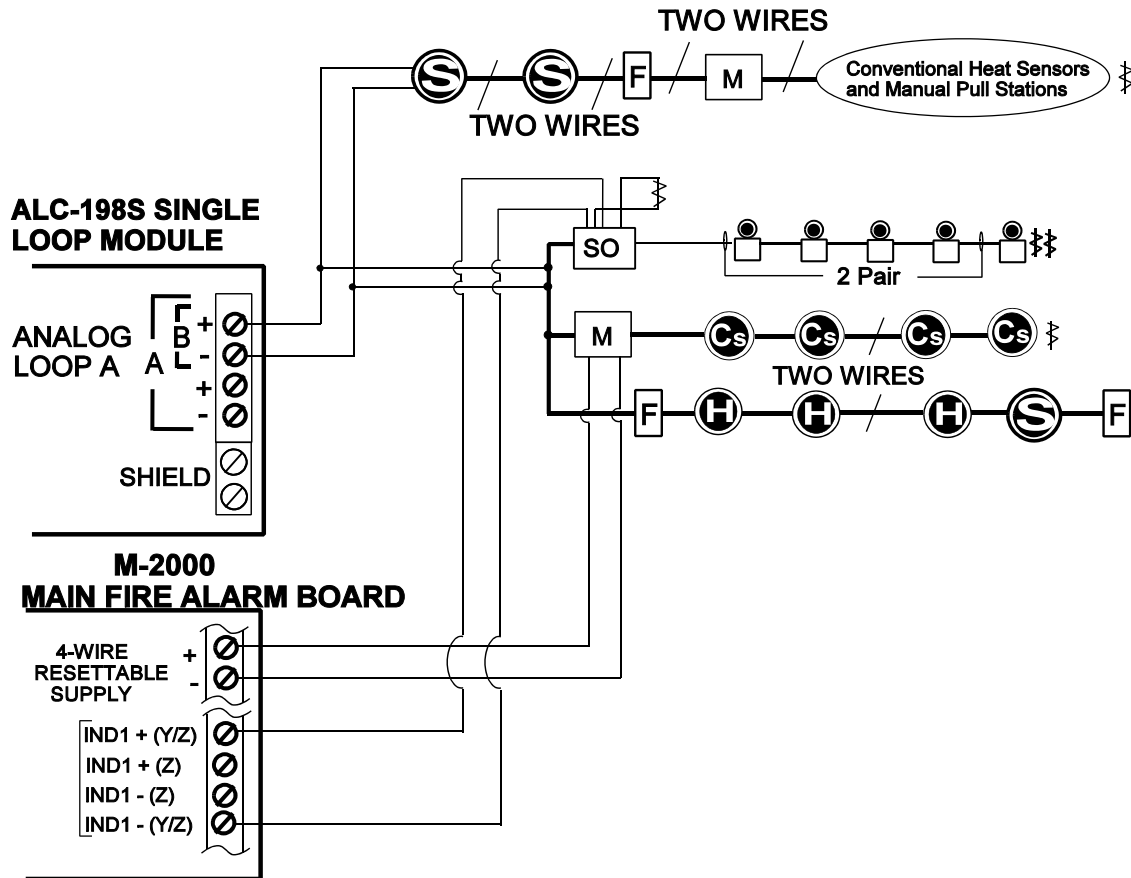

**NOTES:**

**ALL POWER LIMITED CIRCUITS MUST USE TYPE FPL, FPLR, OR FPLP POWER LIMITED CABLE.**

**LOOP WIRING:** MAXIMUM LOOP RESISTANCE IS 40 OHMS TOTAL. THESE LINES ARE FULLY SUPERVISED.

**SHIELD:** IF USING SHIELDED WIRE, CONNECT ONLY ONE END OF THE SHIELD TO TERMINAL MARKED SHIELD.

# LEGEND

- |  |  |
|--|--|
| <ul style="list-style-type: none"> <li> Addressable Smoke Sensor with Standard Analog Base</li> <li> Addressable Thermal Sensor with Standard Analog Base</li> <li> Conventional Smoke Sensor</li> <li> Addressable Manual Pull Station</li> </ul> | <ul style="list-style-type: none"> <li> Combination Horn/Strobe</li> <li> Addressable Monitor Module</li> <li> Addressable Supvr. Output Module</li> </ul> |
|--|--|
- End-Of-Line-Resistor

# SINGLE ADDRESSABLE LOOP STYLE 7 WIRING

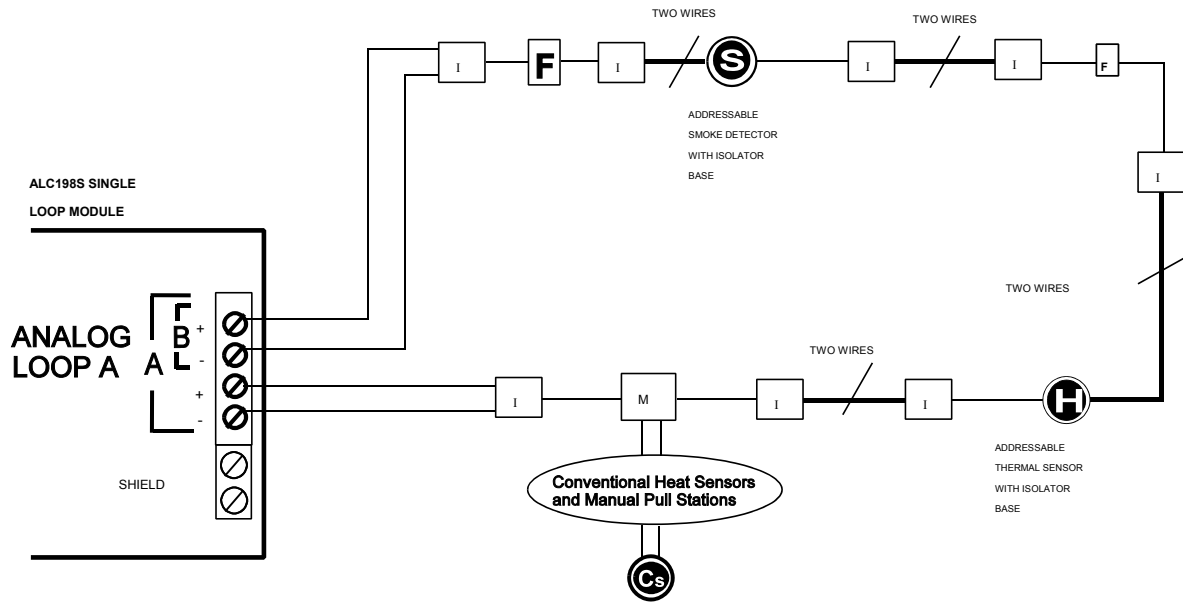

STYLE 7: For Style 7 operation use isolator bases for the detectors and use Isolator modules (front and back as shown in this diagram) for the addressable pull stations, monitor modules, and control modules

**NOTES** \_\_\_\_\_:

ALL POWER LIMITED CIRCUITS MUST USE TY, FPL, FPLR OR FPLP POWER LIMITED CABLE.

ISOLATORS NEED TO BE CLOSE NIPPLE CONNECTED TO THE DEVICE BEING PROTECTED.

**LOOP WIRING** \_\_\_\_\_: MAXIMUM LOOP RESISTANCE 40 OHMS TOTAL. THESE LINES ARE FULLY SUPERVISED.

**SHIELD:** \_\_\_\_\_ IF USING SHIELDED WIRE, CONNECT ONLY ONE END OF THE SHIELD TO TERMINAL MARKED SHIELD ON THE LOOP ADDER BOARD.

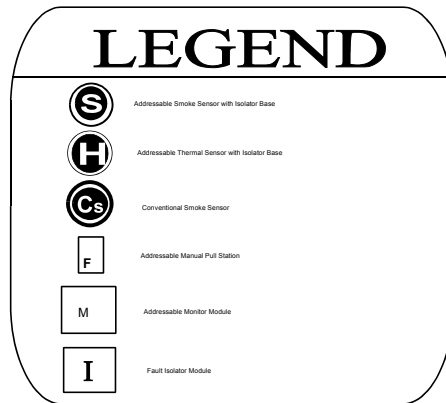

# SINGLE ADDRESSABLE LOOP STYLE 6 WIRING

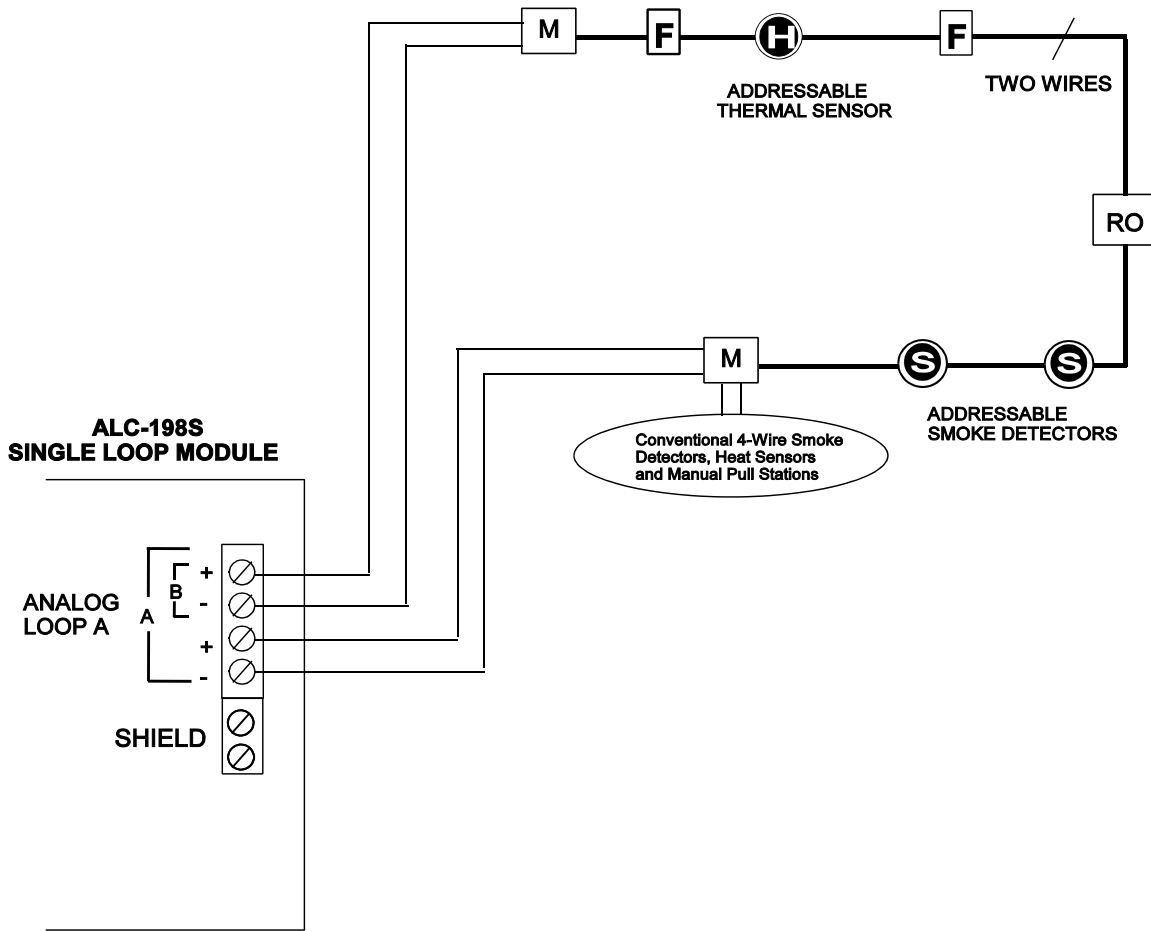

**NOTES:**

ALL POWER LIMITED CIRCUITS MUST USE TY, FPL, FPLR OR FPLP POWER LIMITED CABLE.

**LOOP WIRING:** MAXIMUM LOOP RESISTANCE 40 OHMS TOTAL. THESE LINES ARE FULLY SUPERVISED.

**SHIELD:** IF USING SHIELDED WIRE, CONNECT ONLY ONE END OF THE SHIELD TO TERMINAL MARKED SHIELD ON THE LOOP ADDER BOARD.

## LEGEND

(S)	Addressable Smoke Sensor
(T)	Addressable Thermal Sensor
(M)	Addressable Manual Pull Station
[M]	Addressable Monitor Module
[RO]	Addressable Relay Output Module