

# FR-320 Series

Pre-Action/Deluge and Agent Release Control Panel



**FM APPLICATIONS MUST HAVE CLASS A INITIATING CIRCUITS ONLY  
(FOR RELEASING) AND 90 HOUR BATTERY STANDBY OPERATION**



# Table of Contents

<b>1.0</b>	<b>Introduction</b>	<b>8</b>
1.1	Panel Type .....	8
1.2	Overall Features .....	8
<b>2.0</b>	<b>Conventions</b>	<b>10</b>
2.1	Circuits .....	10
2.2	Zone .....	10
2.3	Display Points .....	10
2.4	Wiring Classes .....	10
<b>3.0</b>	<b>System Components</b>	<b>11</b>
3.1	Main Pre-Action/Deluge and Agent Release Control Panel .....	11
3.2	FR-320 Series System Components .....	12
3.3	Additional System Accessories .....	13
<b>4.0</b>	<b>Mechanical Installation</b>	<b>14</b>
4.1	Installing the Enclosure .....	14
4.2	BBX-1024DS and BBX-1024DSR Mechanical Installation .....	16
4.3	Installing the Adder Modules .....	17
<b>5.0</b>	<b>Cable and Jumper Connections for Main Board, Core Board and Adder Modules</b>	<b>18</b>
5.1	Main Pre-Action/Deluge and Agent Release Control Board .....	18
5.2	ICAC-306 Input Class A Converter Adder Module .....	19
5.3	OCAC-302 Output Class A Converter Adder Module .....	20
5.4	RM-306 Relay Adder Module .....	20
5.5	Annunciators .....	21
5.6	SRM-312R/SRM-312W .....	21
5.7	RTI-1 Remote Trouble Indicator .....	21
<b>6.0</b>	<b>Field Wiring</b>	<b>22</b>
6.1	Main Board Field Wiring .....	22
6.2	Abort and Manual Release Switch Wiring .....	23
6.3	Notification Appliance Circuit Wiring .....	25
6.4	Releasing Circuit Wiring .....	26

6.5	Four-Wire Smoke Detector Wiring .....	27
6.6	Relay Adder Module Wiring .....	27
6.7	Releasing Circuit Bypass Switch Wiring .....	28
6.8	Power Supply Connection .....	28
6.9	Wiring Tables and Information .....	30
6.10	Releasing Circuits .....	31
6.11	Annunciators .....	31
6.12	Four-Wire Smoke Power (regulated) .....	31
6.13	Supervised Auxiliary Power (regulated) .....	31
6.14	Unfiltered Supply (full wave rectified) .....	31
<b>7.0</b>	<b>System Checkout</b> .....	<b>32</b>
7.1	Before turning the power “ON” .....	32
7.2	Power-up procedure .....	33
7.3	Troubleshooting .....	33
<b>8.0</b>	<b>Indicators, Controls and Operations</b> .....	<b>34</b>
8.1	Common LED Indicators .....	34
8.2	Menu Buttons .....	36
8.3	Switches and Common Indicators .....	36
8.4	Circuit (Zone) Disconnect Buttons (Bypass Switches) .....	37
8.5	Common Controls .....	37
8.6	Common Relays .....	38
8.7	Circuit Types .....	39
8.8	Evacuation codes .....	41
<b>9.0</b>	<b>Configuration</b> .....	<b>42</b>
9.1	Using the CFG-300 Tool .....	44
9.2	Entering the Passcode .....	45
9.3	How to Use the Keypad to Program the FR-320 Series .....	45
9.4	Command Menu .....	46
9.5	1. Panel Config (Command-Menu) .....	47
9.6	2. Set Time (Command-Menu) .....	52
9.7	3. Set Password (Command-Menu) .....	54
9.8	4. View Event Log (Command-Menu) .....	54
9.9	5. Print Event Log .....	55
9.10	6. Clear Event Log (Command-Menu) .....	58
9.11	7. Exit (Command-Menu) .....	58
<b>10.0</b>	<b>Operating the Panel</b> .....	<b>59</b>
10.1	Panel Operation During Various Hazard States .....	59

10.2	General Panel Operation .....	60
<b>11.0</b>	<b>Pre-Programmed Modes</b>	<b>62</b>
11.1	Mode 1: Agent Release, Single Hazard, Cross-zoned, Combined Release .....	62
11.2	Mode 2: Agent Release, Single Hazard, Not Cross-zoned, Combined Release .....	64
11.3	Mode 3: Agent Release, Dual Hazard, Cross-zoned, Split Release .....	66
11.4	Mode 4: Agent Release, Dual Hazard, Not Cross-zoned, Split Release .....	68
11.5	Mode 5: Pre-action/Deluge, Single Hazard, Cross-zoned, Combined Release .....	70
11.6	Mode 6: Pre-action/Deluge, Single Hazard, Not Cross-zoned, Combined Release .....	71
11.7	Mode 7: Pre-action/Deluge, Dual Hazard, Cross-zoned, Split Release .....	72
11.8	Mode 8: Pre-action/Deluge, Dual Hazard, Not Cross-zoned, Split Release .....	74
11.9	Mode 9: Agent Release, Single Hazard, Cross-zoned, NYC abort .....	76
11.10	Mode 10: Agent Release, Single Hazard, Not Cross-zoned, Combined Release .....	78
11.11	Mode 11: Agent Release, Single Hazard, Cross-zoned, Combined Release .....	80
11.12	Mode 12: Pre-action/Deluge, Single Hazard, Cross-zoned, Combined Release .....	82
11.13	Mode 13: Pre-action/Deluge, Single Hazard, Not Cross-zoned, Combined Release ....	84
11.14	Mode 14: Pre-action/Deluge, Single Hazard, Not Cross-zoned, Combined Release ....	85
	<b>Appendix A: Compatible Solenoids</b>	<b>87</b>
	<b>Appendix B: Compatible Synchronized Modules and Horn/Strobes (UL/ULC)</b>	<b>88</b>
	<b>Appendix C: Specifications</b>	<b>90</b>
	<b>Appendix D: Power Supply and Battery Calculations</b>	<b>93</b>
	<b>Warranty and Warning Information</b>	<b>94</b>

## List of Figures

Figure 1	FR-320 Series panel .....	11
Figure 2	Enclosure dimensions .....	14
Figure 3	Box dimensions, semi-flush mounting and trim ring .....	15
Figure 4	Flush Trim Detail .....	15
Figure 5	BBX-1024DS and BBX-1024DSR installation instructions and dimensions .....	16
Figure 6	Installation of Adder Modules .....	17
Figure 7	Main Control Board cable connector and jumper settings .....	18
Figure 8	ICAC-306 input class A converter adder module .....	19
Figure 9	OCAC-302 output class A converter adder module .....	20
Figure 10	RM-306 six relay adder module .....	21
Figure 11	Initiating Device Circuit – class B wiring .....	22
Figure 12	Initiating Device Circuit– class A wiring .....	22
Figure 13	Abort and manual release switch class B wiring .....	23
Figure 14	Abort and manual release switch class A wiring .....	24
Figure 15	Notification Appliance Circuit – class B wiring .....	25
Figure 16	Notification Appliance Circuit – class A wiring .....	25
Figure 17	Releasing circuit wiring .....	26
Figure 18	Four-wire smoke detector wiring - class B .....	27
Figure 19	Relay per zone (RM-306) terminal connection .....	27
Figure 20	Release Circuit Bypass Switch Wiring .....	28
Figure 21	Power supply connection .....	29
Figure 22	LED indicators and control buttons .....	34
Figure 23	Evacuation and alert codes .....	41
Figure 24	FR-320 Series configuration .....	44
Figure 25	Command menu .....	46
Figure 26	Event log .....	55
Figure 27	Connect the computer to the P7 connector on the main FR-320 Series board .....	55
Figure 28	Tera Term New connection .....	56
Figure 29	Tera Term Serial port setup .....	56
Figure 30	Example event log printout .....	57
Figure 31	1 release timer active .....	60
Figure 32	2 release timers active .....	60

## List of Tables

Table 1	FR-320 Series System Components .....	12
Table 2	Power Supply Rating .....	28
Table 3	Initiating Device Circuit Wiring Distances .....	30
Table 4	Notification Appliance Circuit Wiring Distances .....	30
Table 5	Releasing Circuits Wiring Table .....	31
Table 6	RS-485 Wiring to Annunciators and other Devices .....	31
Table 7	Troubleshooting .....	33
Table 8	Common Relays .....	38
Table 9	Settings Permitted in CAN/ULCS527 .....	42
Table 10	Settings Permitted in UL864 .....	43
Table 11	Access Levels .....	45
Table 12	FR-320 Series Specifications .....	90
Table 13	FR-320 Series System Modules and Annunciators .....	91

# 1.0 Introduction

Mircom's FR-320 Series Pre-Action/Deluge and Agent Release Control Panel performs the function of fire suppression in a wide variety of applications. It is capable of being used in an agent release sprinkler system or in a pre-action or deluge sprinkler system. It can be used in single-hazard or dual-hazard applications with or without cross-zoning. The panel includes common alarm, supervisory, and trouble relays, and provides regulated and unregulated auxiliary power along with four-wire smoke power. It supports auxiliary relays. The auxiliary relays are based on a hazard area status. The FR-320 Series has six input zones and four output zones, allowing for flexibility in most single and dual-hazard applications for both deluge and agent releasing applications.

## 1.1 Panel Type

The panel can function as an agent release panel or as a pre-action/deluge panel, depending on which of the available fixed configurations are chosen from the main programming menu.

### 1.1.1 Deluge sprinkler system

In deluge sprinkler systems open-valve sprinkler heads terminate to a water supply that is controlled by a single valve. When the system detects fire, it automatically opens the valve via a releasing circuit, allowing the water to flow through all the sprinkler heads. Deluge sprinkler systems are useful for applications in which simultaneous discharge of water through every sprinkler is required.

### 1.1.2 Pre-action sprinkler system

In a pre-action sprinkler system close-valve sprinkler heads are connected to pipes that are supervised for air pressure. The pipes terminate directly to a water supply. Pre-action systems are useful for applications in which the prevention of an accidental discharge of water is required.

### 1.1.3 Agent release system

In an agent release system, an extinguishing agent (such as Argon, dry chemical, CO<sup>2</sup>, Halon, etc.) is automatically released upon fire detection. An abort function is added to prevent the false release of the extinguishing agent.

## 1.2 Overall Features

- 6 class B Initiating Device Circuits, which may be configured as class A using input class A converter adder modules. Each Initiating Device Circuit is pre-configured as Alarm, Supervisory (Latching or non-latching), water-flow, Manual Release Switch, or Abort Switch. There are two LEDs per circuit, one for Trouble (amber), and one dual color (amber/red) LED for Supervisory (amber) and Alarm (red).
- 4 power limited class B output circuits. Output circuits 1 & 2 are Notification Appliance Circuits while output circuits 3 & 4 are releasing circuits (circuit 4 can work as a Notification Appliance Circuit in some situations; check section 11 for details). Each Notification Appliance Circuit process type is pre-configured and can be silenceable. The signal rates depend on the selected pre-programmed configuration.
- A pushbutton associated with each Initiating Device Circuit and Notification Appliance Circuit can individually disconnect (bypass) the circuit.
- Configurable Signal Silence Inhibit and Auto Signal Silence Timers.
- Subsequent Alarm, Supervisory, and Trouble operation.
- Non-resettable auxiliary power supply, 300mA max.
- Four wire resettable smoke power supply, 100mA max.

- Relay Contacts for Common Alarm, Common Supervisory, Common Trouble, and Auxiliary Alarm Relay (disconnectable).
- RS-485 Interface for RA-1000 Series Remote Multiplex Annunciators and Smart relay Module.
- Optional Modules for additional Relay Circuits.
- Extensive transient protection.
- Easy configuration of the panel using LCD service tool (CFG-300).
- Releasing circuit protection from false alarm by disconnecting the battery if the voltage falls below 20.4V at the last releasing device.
- Wide range of compatible solenoids (see Appendix A).
- 14 pre-programmed modes.

## **2.0 Conventions**

### **2.1 Circuits**

Refers to an actual electrical interface for initiating (detection), Notification Appliance Circuits (signal), and releasing.

### **2.2 Zone**

Is a logical concept for a Fire Alarm Protected Area, and will consist of at least one Circuit.

Often the terms Zone and Circuit are used interchangeably, but in this Manual the term Circuit is used.

### **2.3 Display Points**

There is a display point associated with every Initiating Device Circuit and Notification Appliance Circuit of the FR-320 Series fire panel. For an Initiating Device Circuit there are two LEDs for every display point: one single color (amber) and one dual color (red/amber). For a Notification Appliance Circuit there is only one LED: one single color (amber), for every display point.

### **2.4 Wiring Classes**

Initiating Device Circuits and Notification Appliance Circuits are class B. Changing the Initiating Device Circuits to class A requires an ICAC-306 adder board which will convert SIX initiating zones from class B circuits to class A. This is done without penalizing the number of circuits, which remains the same as in class B. Changing the Notification Appliance Circuits to class A requires an OCAC-302 adder board, which will convert TWO indicating zones from class B circuits to class A. Releasing circuits are class B only.

## 3.0 System Components

### 3.1 Main Pre-Action/Deluge and Agent Release Control Panel

The following models are part of the FR-320 Series:

- FR-320
- FR-320-W
- FR-320-R



Figure 1 FR-320 Series panel

All FR-320 Series panels have the following features:





- Six Zone Pre-Action/Deluge and Agent Release Control Panel with LED display (red or white door, black box)
- Six class B Initiating Device Circuits, and four class B output circuits
- Output circuits 1 & 2 are class B Notification Appliance Circuits that can be converted to class A using an **OCAC-302 Output Class A Converter** adder module.
- Output circuits 3 & 4 are class B only releasing circuits.
- Each output circuit can supply up to 1.7A of current, 5A total. A six zone **ICAC-306 Input Class A Converter** adder module may be used for class A wiring of Initiating Device Circuits.
- The FR-320 Series contains Common Alarm, Common Supervisory & Common Trouble relays, auxiliary alarm relay (disconnectable), an RS-485 interface for remote annunciators, non-resettable auxiliary power, and a resettable four wire smoke detector power supply.
- Two batteries are required.

Additionally:

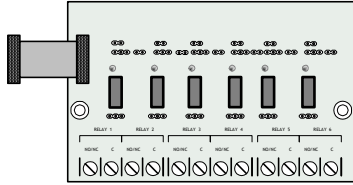

- FR-320 uses a BBX-1024DS or BBX-1024DSR enclosure.

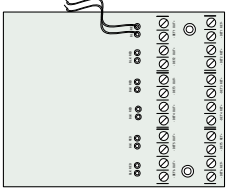
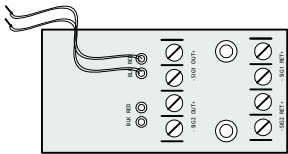
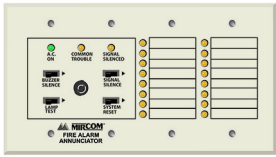
### 3.2 FR-320 Series System Components

Table 1 FR-320 Series System Components

	Model	Description
	<b>RM-306</b>	Six-relay adder module
	<b>SRM-312W</b>	Smart Relay Module (12 relays) with white enclosure
	<b>SRM-312R</b>	Smart Relay Module (12 relays) with red enclosure
	<b>ICAC-306</b>	Input Class A converter Module (six circuits). This module has built-in active EOL resistors.
	<b>OCAC-302</b>	Output Class A converter module (two circuits)
	<b>RAM-216</b>	16 Zone ancillary annunciator with white enclosure
	<b>RAM-216R</b>	16 Zone ancillary annunciator with red enclosure
	<b>RAM-208</b> <b>RAM-208R</b>	Eight Zone Remote Annunciator with white or red enclosure

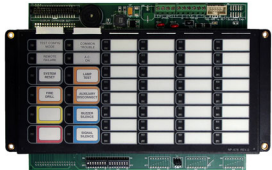
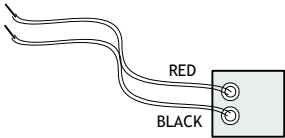
**Table 1 FR-320 Series System Components (Continued)**

	<b>Model</b>	<b>Description</b>
	<b>RAM-300LCDW</b>	Remote Annunciator module, LCD display, white painted box
	<b>RAM-300LCDR</b>	Remote Annunciator Module, LCD display, red painted box
	<b>RAM-1032TZDS</b> <b>RAM-1032TZDS-CC</b>	Model RAM-1032TZDS Main Chassis Remote Annunciator with 16 bi-colored LEDs and 32 trouble LEDs. Model RAM-1032TZDS-CC is the same as the RAM-1032TZDS, except it has conformal coating and is to be used in a BB-1001WPA/BB-1001WPRA weather protected box.
	<b>ELRX-300</b>	Active end-of-line resistor without plate
	<b>ELRX-300R</b>	Active end-of-line resistor with end-of-line red plate The ELRX-300 and ELRX-300R are power-saving end-of-line resistors that eliminate the need for an additional battery cabinet or larger batteries in order to meet the 60 hour standby requirement.
	<b>BB-1001D</b>	White Enclosure for one annunciator
	<b>BB-1001DR</b>	Red Enclosure for one annunciator
	<b>BB-1001DB</b>	Black Enclosure for one annunciator
	<b>BB-1001DS</b>	Enclosure for one annunciator with stainless steel door
	<b>BB-1001WPA</b>	White enclosure for one annunciator rated for outdoor environment, wet location
	<b>BB-1001WPRA</b>	Red enclosure for one annunciator rated for outdoor environment, wet location

### 3.3 Additional System Accessories

<b>RTI-1</b>	Remote Trouble Indicator	(ULC and ULI Approved)
<b>RAM-1016TZDS</b>	Remote Annunciator	(ULC and ULI Approved)
<b>MP-300</b>	EOL resistor plate, 3.9 kΩ	(ULC and ULI Approved)
<b>MP-300R</b>	EOL resistor plate, red	(ULC and ULI Approved)
<b>BC-160(R)</b>	External Battery Cabinet	(ULC and ULI Approved)
<b>MP-320R/W</b>	Solenoid EOL Module	(ULC and ULI Approved)

# 4.0 Mechanical Installation



**Note:** Installation, use and maintenance should be in accordance with the manufacturer's documents and the National Electrical Code, ANSI/NFPA 70, and the National Fire Alarm Code ANSI/NFPA 72.

## 4.1 Installing the Enclosure

Install the FR-320-R/W panel enclosure as shown in Figure 2 and Figure 3. Mount enclosure surface mount using the four mounting holes with the provided screws.

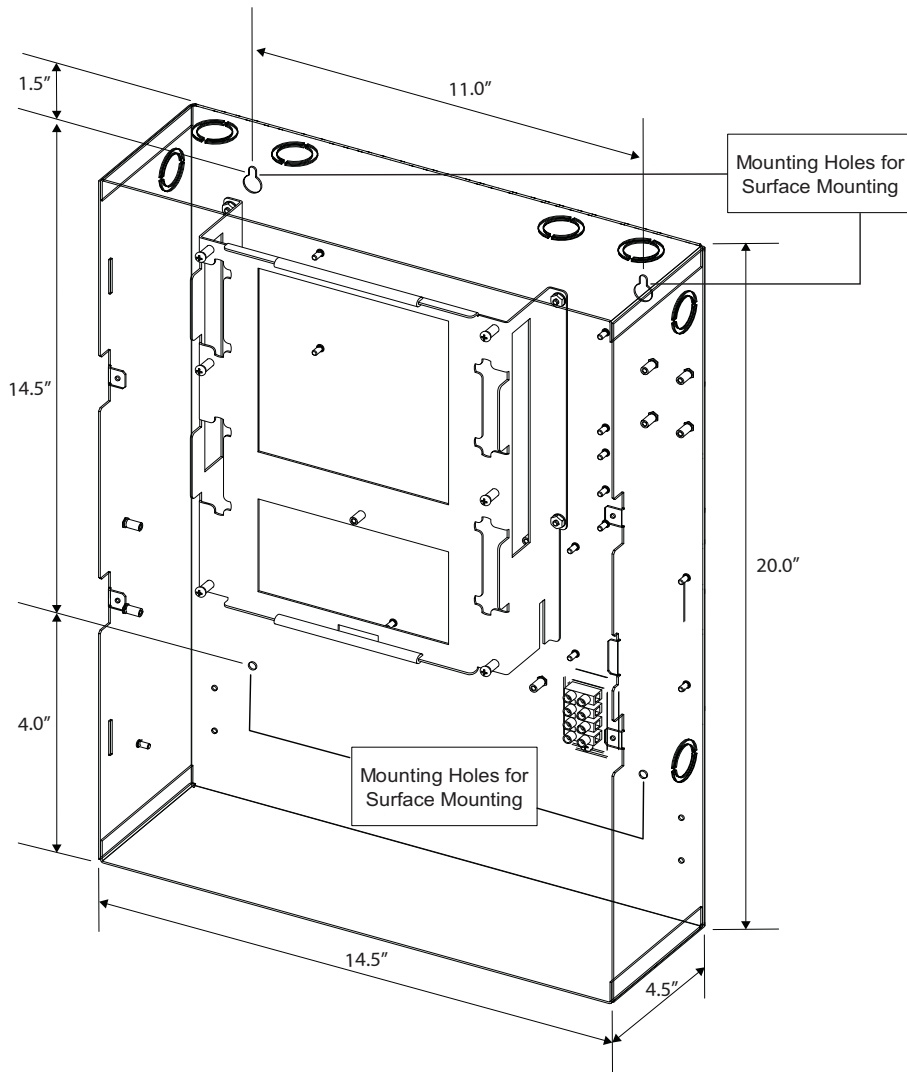

**Figure 2 Enclosure dimensions**

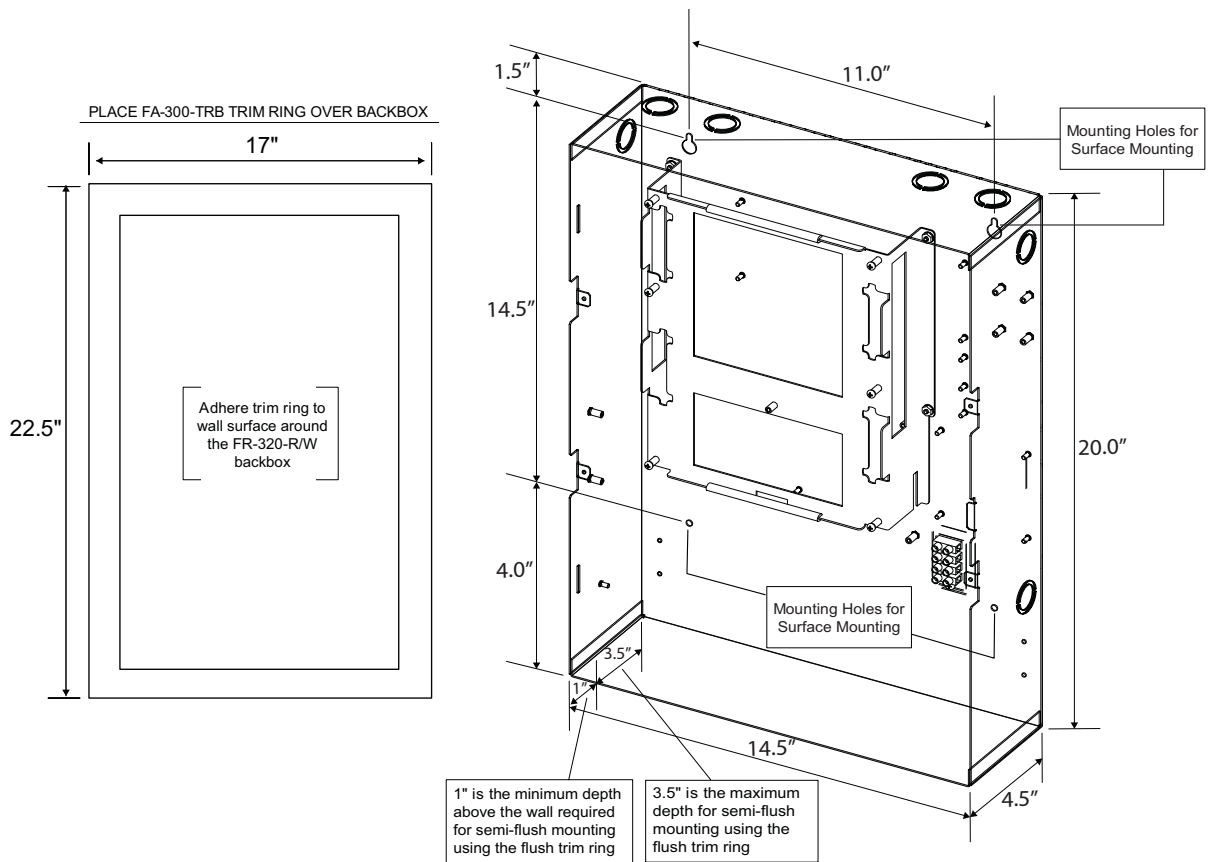

**Figure 3 Box dimensions, semi-flush mounting and trim ring**

Remove the door (also disconnect the ground strap), the dead front and semi-flush mount the backbox into the wall. Peel the adhesive cover from the FA-300-TRB trim ring and stick it to the wall surface around the backbox, after the wall is finished.

Figure 4 shows a cross-section of the semi-flush mounted backbox and the trim ring. **Make sure to allow a minimum depth of 1" above the wall surface for proper door opening.**

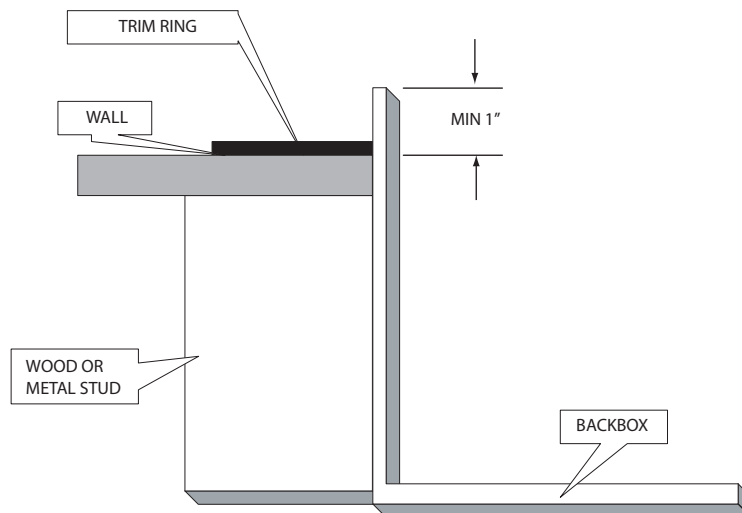

**Figure 4 Flush Trim Detail**

## 4.2 BBX-1024DS and BBX-1024DSR Mechanical Installation

The BBX-1024DS and BBX-1024DSR are suitable for flush or surface mounting, and have a built-in trim ring.

<b>Dimensions of Enclosure (minus built in trim ring)</b>	14 1/2" x 4 1/4" x 26"
<b>Distance between horizontal mounting screws</b>	12"
<b>Distance between vertical mounting screws</b>	23 1/2"
<b>Complete Dimensions of Enclosures</b>	16 3/4" x 5 1/2" x 28"

External Dimensions

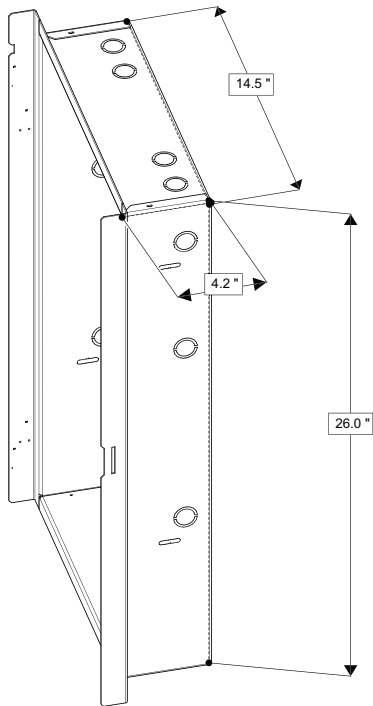

Mounting Dimensions

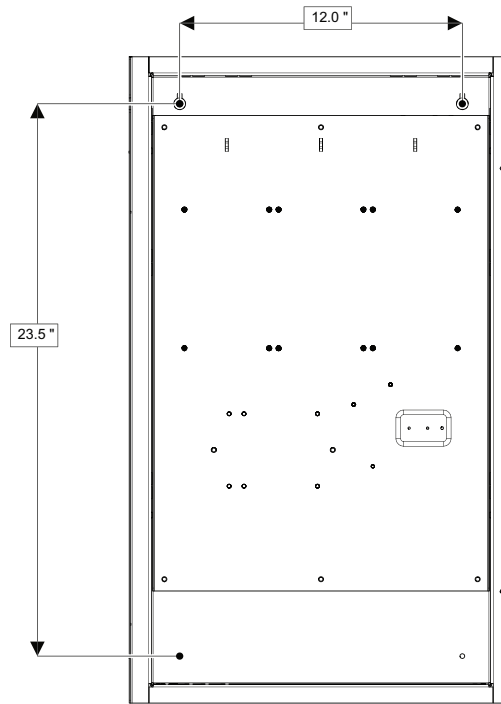

Side View

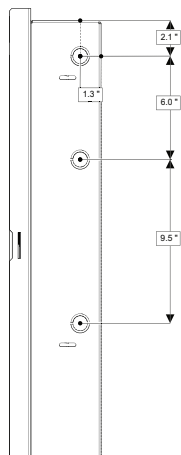

Top View

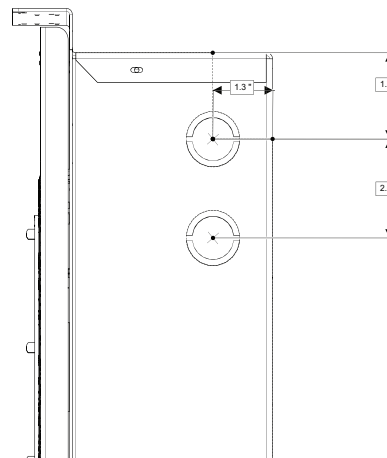
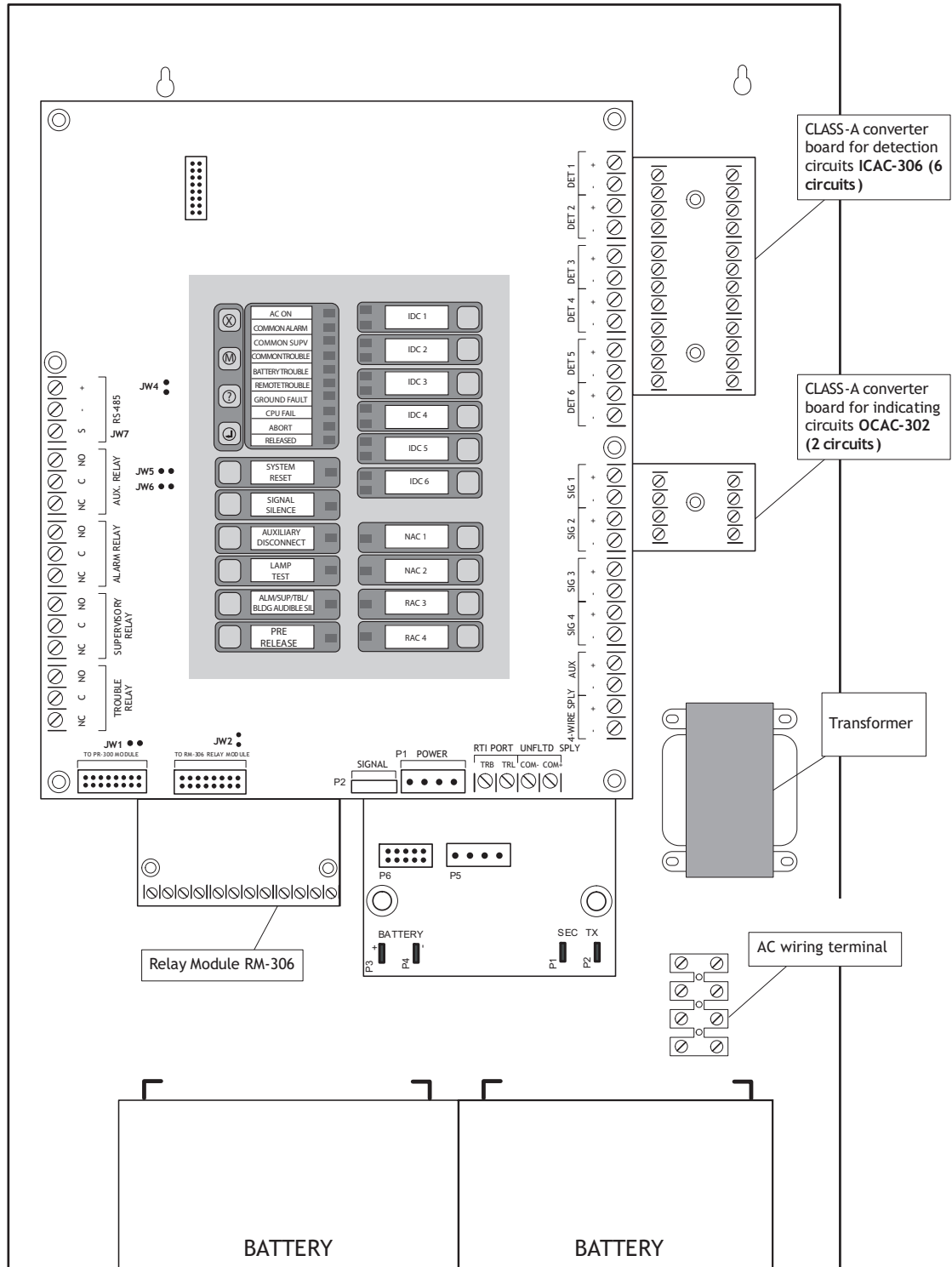

Figure 5 BBX-1024DS and BBX-1024DSR installation instructions and dimensions

### 4.3 Installing the Adder Modules

The FR-320 Series panel comes pre-assembled with all components and boards except for adder modules. Module installation locations are shown below. Refer to Figure 7 on the next page for Jumper or DIP Switch settings and see section 6.9 for wiring specifications.



**Figure 6 Installation of Adder Modules**

# 5.0 Cable and Jumper Connections for Main Board, Core Board and Adder Modules

## 5.1 Main Pre-Action/Deluge and Agent Release Control Board

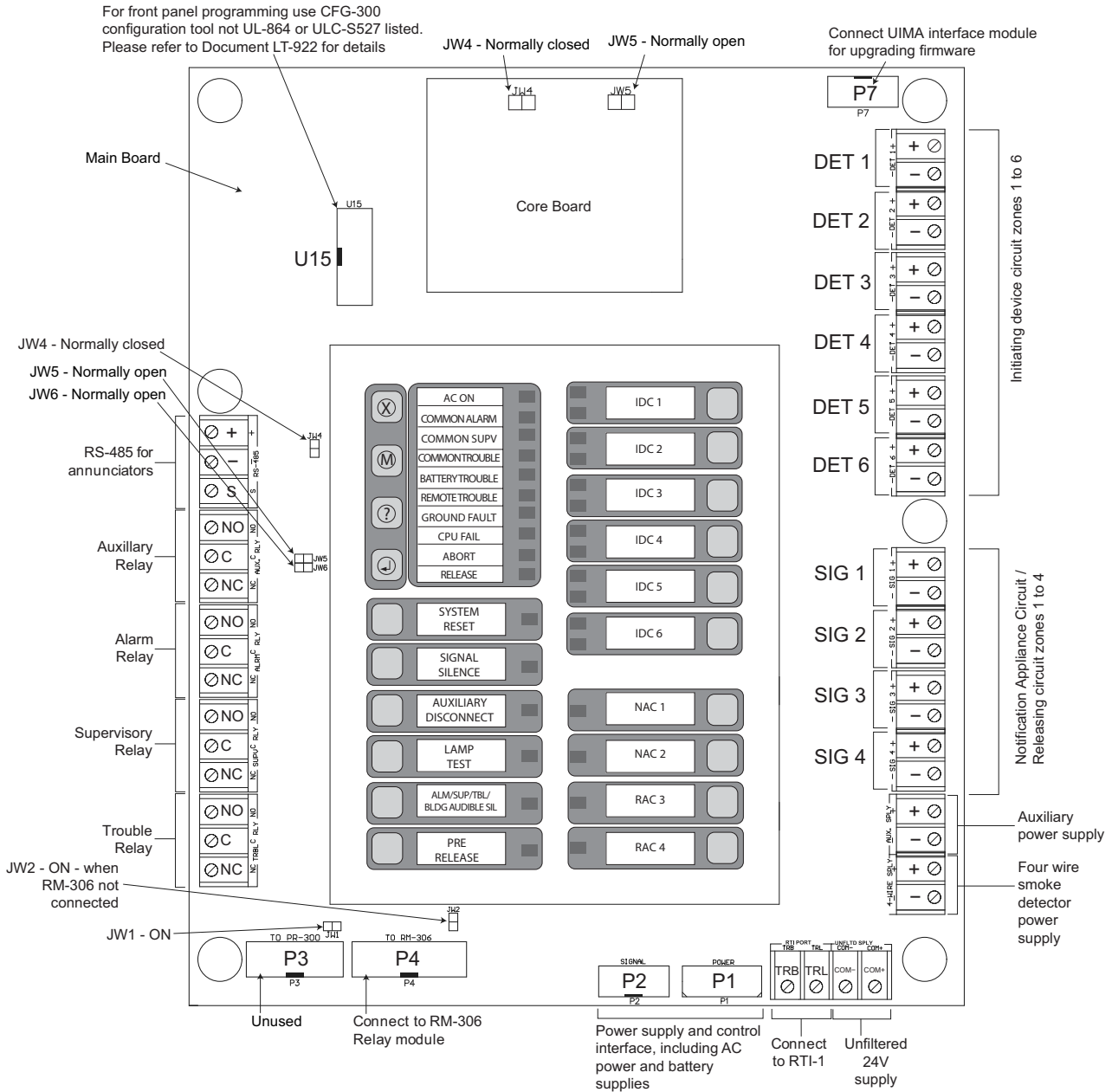

Figure 7 Main Control Board cable connector and jumper settings

### 5.1.1 Connectors and Jumpers on the Main Fire Alarm Board

<b>P1 and P2</b>	Power supply and control interface, including AC power and battery supplies.
<b>P3</b>	Not Used.
<b>P4</b>	Cable from connector <b>P1</b> of the RM-306 Relay Adder Module connects here. Otherwise not used.
<b>P7</b>	Connect UIMA interface module for upgrading firmware.
<b>U15</b>	For front panel programming, use CFG-300 configuration tool not UL-864 or ULC-S527 listed. Please refer to document LT-922 for details.
<b>JW1</b>	Always closed.
<b>JW2</b>	Remove this jumper if an RM-306 Relay Adder Module is used.
<b>JW4</b>	Closed if there is no external unit on RS485. This jumper works as 'end of line' jumper. If one or more units are connected on RS485, only short on the last connected unit. JW4 on all other units should be left open.
<b>JW5</b>	Normally open. To reset the password, place jumper here and power down the panel (both AC power and batteries). Then power up the panel again, the password is restored to the default after system startup. Once the system has reset, <b>REMOVE</b> the jumper from the pins at JW5.
<b>JW6</b>	Normally open to BLOCK configuration via modem, PC with a UIMA converter module or a CFG-300 Configuration Tool. Place jumper here to ALLOW any type of configuration.

### 5.1.2 Connectors and Jumpers on the Core Board (Plug-in Board above Switches)

<b>JW4</b>	Leave closed (on).
<b>JW5</b>	Leave open (off).

## 5.2 ICAC-306 Input Class A Converter Adder Module

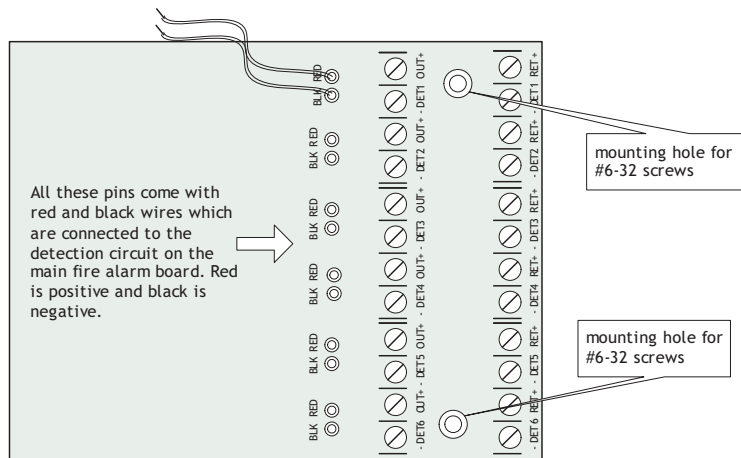

**Figure 8 ICAC-306 input class A converter adder module**

There are no jumpers or cables to set on this module, just wiring from the converter (wires are

fixed here) to the Main Fire Alarm Board.

Initiating Device Circuits must be wired from the ICAC-306 module to the Main Fire Alarm board. For example, Initiating Device Circuit 1 positive (red) and negative (black) wires are connected to the positive and negative terminals (respectively) of Initiating Device Circuit 1 on the Main Fire Alarm Board. From the ICAC-306 converter Initiating Device Circuits are wired out to the devices from the positive and negative terminals marked DET OUT and the circuit return wires are brought back to the converter module to positive and negative terminals marked DET RET.

### 5.3 OCAC-302 Output Class A Converter Adder Module

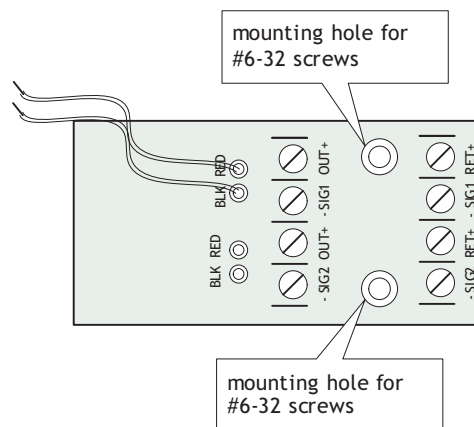

**Figure 9 OCAC-302 output class A converter adder module**

Notification Appliance Circuits must be wired from the OCAC-302 to the main Fire Alarm board. For example Notification Appliance Circuit 1 positive (red wire) and negative (black wire) is wired from the class A converter module to the positive and negative terminals of Notification Appliance Circuit 1 on the Main Fire Alarm board.

The actual indicating zone is wired from the SIGNAL OUT positive and negative to the signaling devices and then wired back to the SIGNAL RET positive and negative.

### 5.4 RM-306 Relay Adder Module

Cable from P1 of the RM-306 is connected to P4 on the Main Fire Alarm Board. The jumpers located above each relay on the RM-306 are used to configure the relays. The jumpers located below the relays are used to select either normally open contacts or normally closed contacts.

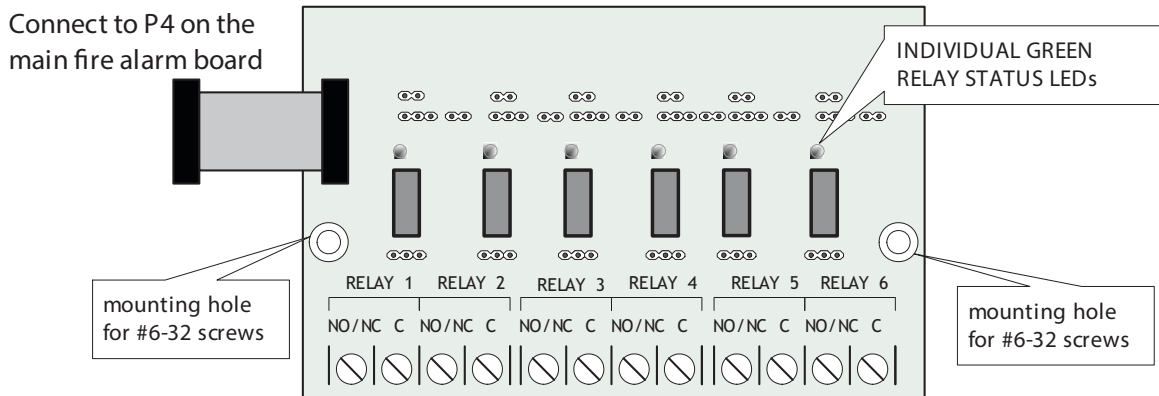

**Figure 10 RM-306 six relay adder module**

### 5.4.1 RM-306 Jumpers

**P1** Cable from RM-306 Relay Adder Module connects to P4 on Main Fire Alarm Board.

### 5.4.2 RM-306 Correlations

The correlation of the relays are fixed and is as follows:

	Relay1	Relay2	Relay3	Relay4	Relay5	Relay6
<b>Active State</b>	Hazard 1 Alert	Hazard 1 Alarm	Hazard 1 Release	Hazard 2 Alert	Hazard 2 Alarm	Hazard 2 Release

## 5.5 Annunciators

Connect the annunciators to the RS-485 terminals and to auxiliary power. Use class B wiring for RS-485. For instructions, see the following Mircom documents:

- RAM-208/RAM-208R: LT-648
- RAM-216/RAM-216R: LT-658
- RAM-300LCDR/RAM-300LCDW: LT-1002
- RAM-1032TZDS(-CC): LT-617

## 5.6 SRM-312R/SRM-312W

Connect SRM-312R/SRM-312W to the RS-485 terminals and to auxiliary power. Use class B wiring for RS-485. For instructions, see LT-1001.

## 5.7 RTI-1 Remote Trouble Indicator

Connect the RTI-1 to the port labeled **RTI-1**. For instructions, see LT-388.

# 6.0 Field Wiring

## 6.1 Main Board Field Wiring

Wire devices to the terminals as shown in the figures that follow. Refer to section 6.9 for wire gauges and Appendix C for specifications.



**Caution:** Do not exceed power supply ratings.

### 6.1.1 Initiating Device Circuit Wiring

Wiring diagrams for the Initiating Device Circuits are shown below. The panel supports class A and B wiring for the Initiating Device Circuits. The Initiating Device Circuits are supervised by a 3.9 kΩ EOL resistor or an active EOL resistor.

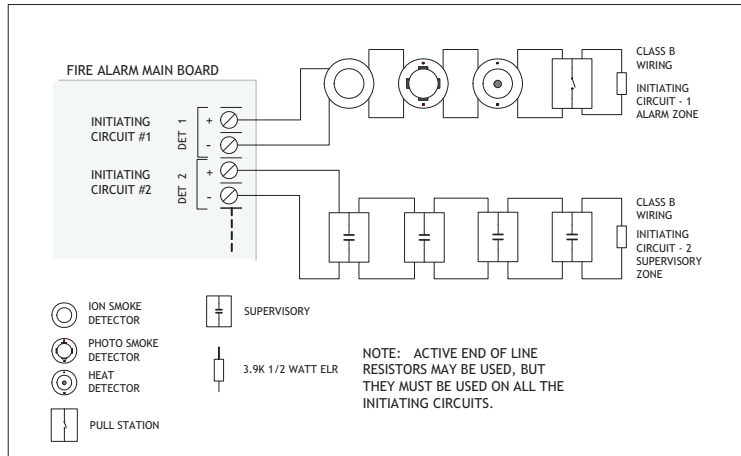

**Figure 11 Initiating Device Circuit – class B wiring**

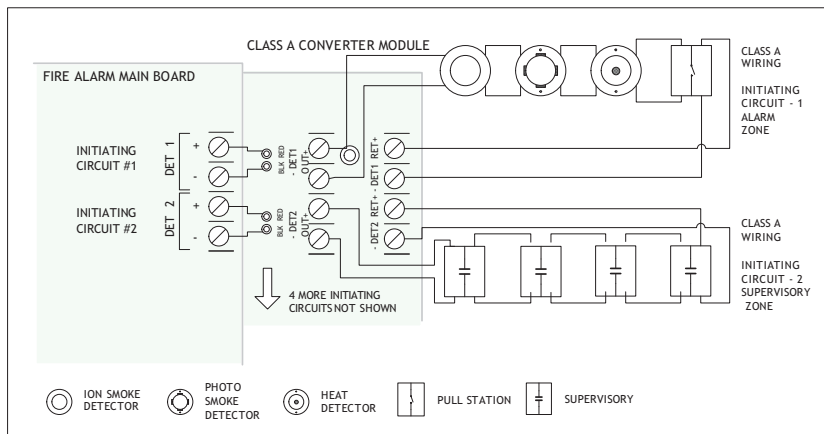
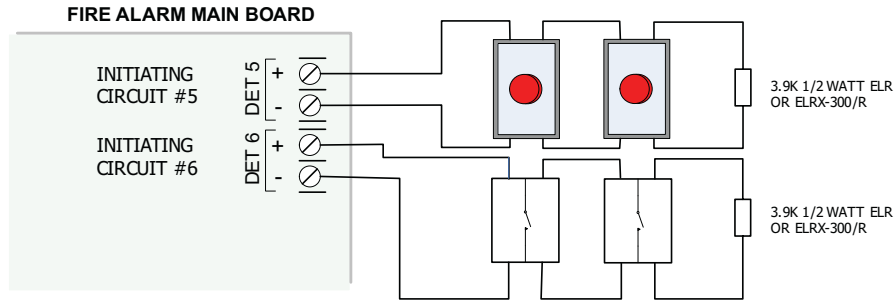

**Figure 12 Initiating Device Circuit– class A wiring**

## 6.2 Abort and Manual Release Switch Wiring

Wiring for the abort and manual release switches is shown in Figure 13 and Figure 14. The Abort and Manual release switches must be on different circuits. DET5 is used for the Abort switch and DET6 is used for the manual release switch.

### Abort and Manual Release switches on separate circuits



### Manual Release switches on separate circuits

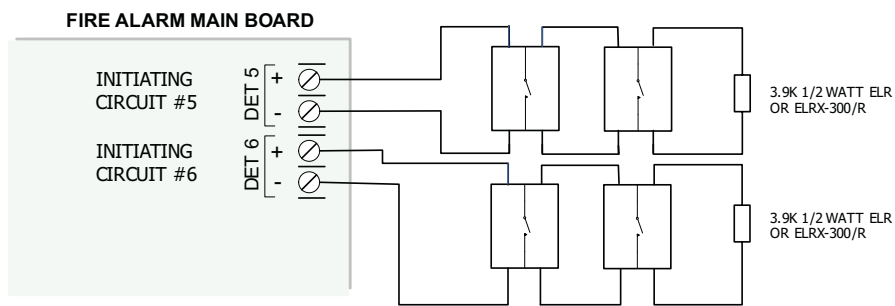

MANUAL RELEASE SWITCH - MUST BE UL38 AND ULC-5528 APPROVED  
Use MS-403,404  
USE ONLY NO CONTACT



ABORT SWITCH  
CONNECT A UL/ULC LISTED ABORT STATION ACCEPTABLE TO THE AHJ, COMPLYING WITH THE FOLLOWING SPECIFICATIONS:  
MAXIMUM IMPEDANCE = 1.4K OHMS  
RATED CURRENT = 45mA  
RATED VOLTAGE= 24V

Figure 13 Abort and manual release switch class B wiring

**FM APPLICATIONS MUST HAVE CLASS A INITIATING CIRCUITS ONLY (FOR RELEASING) AND 90 HOUR BATTERY STANDBY OPERATION**

**Abort and Manual Release switches on separate circuits**

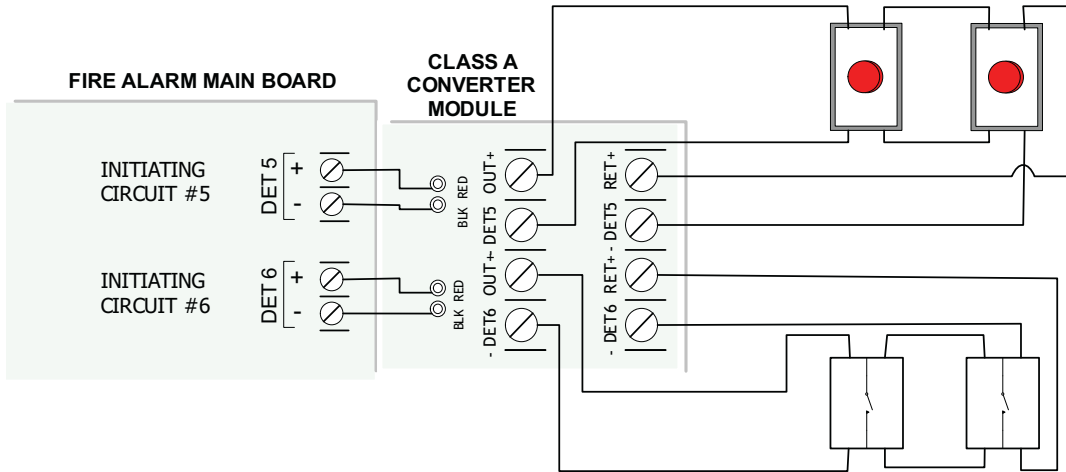

**Manual Release switches on separate circuits**

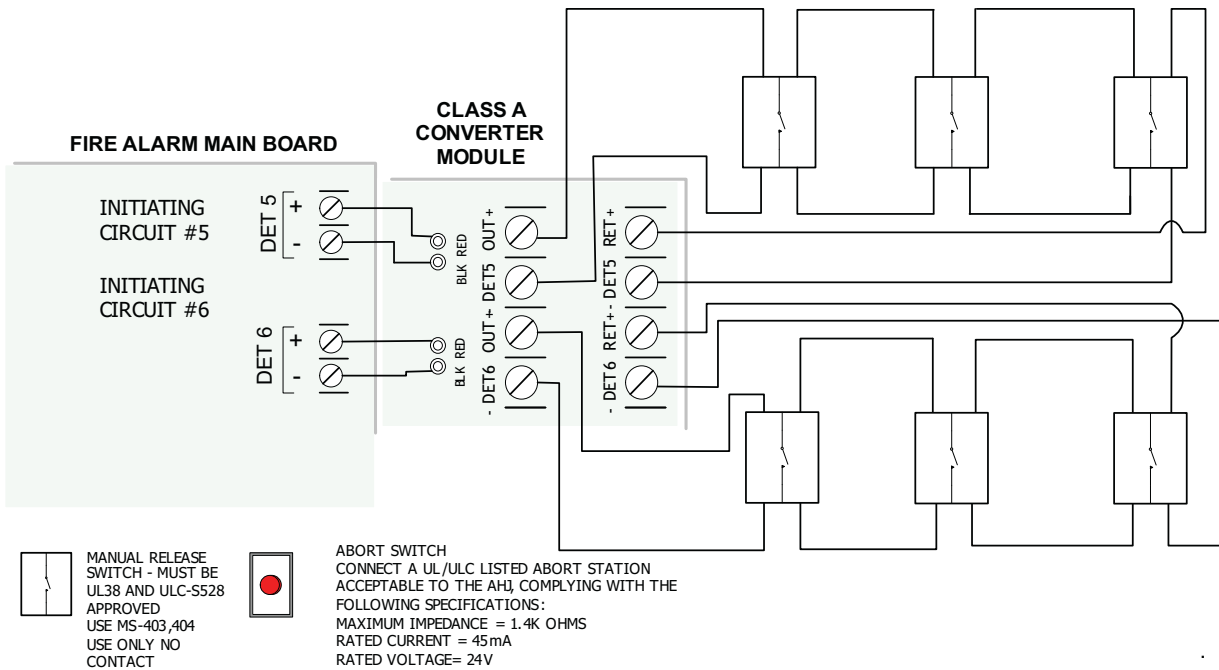

**Figure 14 Abort and manual release switch class A wiring**

### 6.3 Notification Appliance Circuit Wiring

The FR-320 Series Fire Alarm supports class B and class A wiring for its Notification Appliance Circuits. Each circuit is supervised by a 3.9 kΩ EOL resistor or an active EOL resistor. Each Notification Appliance Circuit provides up to 1.7 A, 5 A maximum total if no auxiliaries are used.

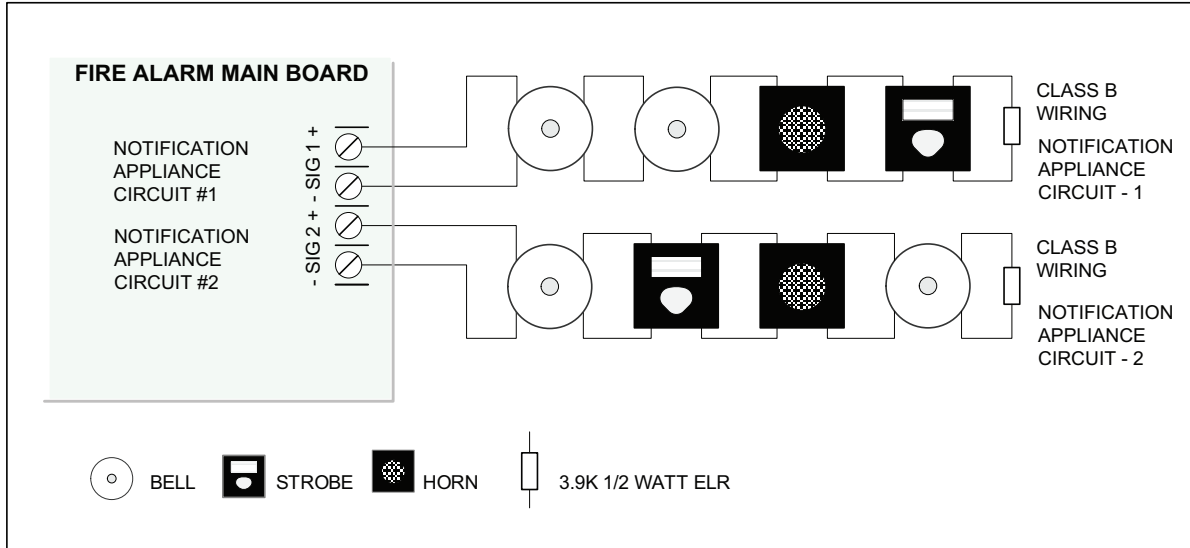

Figure 15 Notification Appliance Circuit – class B wiring

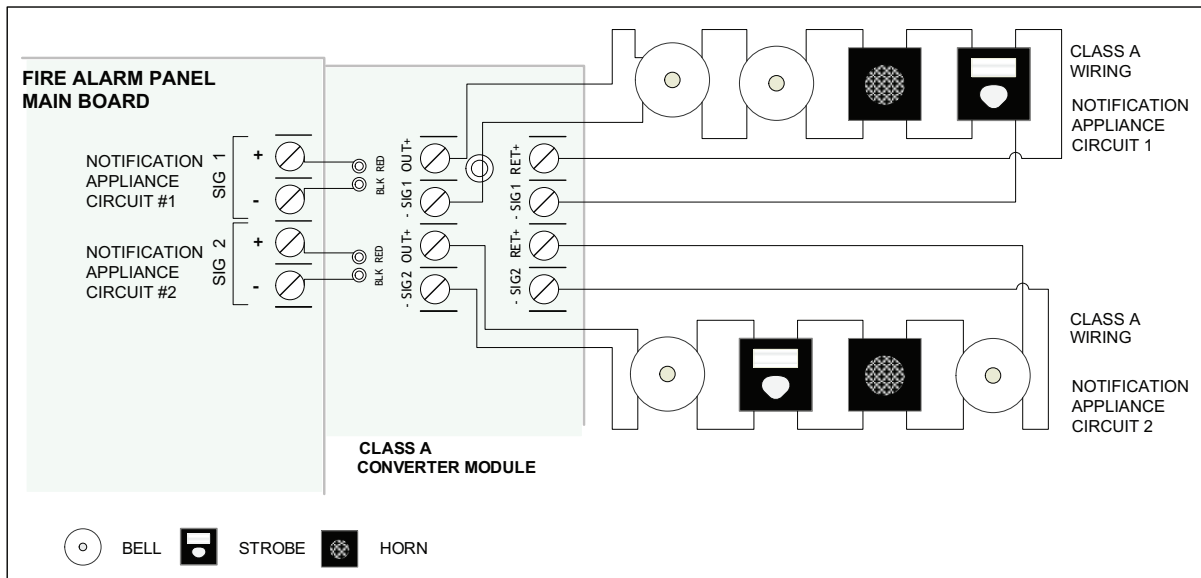

Figure 16 Notification Appliance Circuit – class A wiring

## 6.4 Releasing Circuit Wiring



**Attention:** See Appendix A for the list of compatible solenoids.

Wiring for the releasing circuit is shown in Figure 17 below. SIG3 and SIG4 output circuits are reserved for the releasing circuits. Solenoid EOL module (MP-320R/W) is used to supervise the solenoid coil. If the solenoid is already fitted with the directional diode then only the 3.9kΩ EOL resistor is used. The supervisory current passes through the solenoid coil thus confirming the integrity of the solenoid coil for open coil. The wiring is supervised for the open and short conditions.

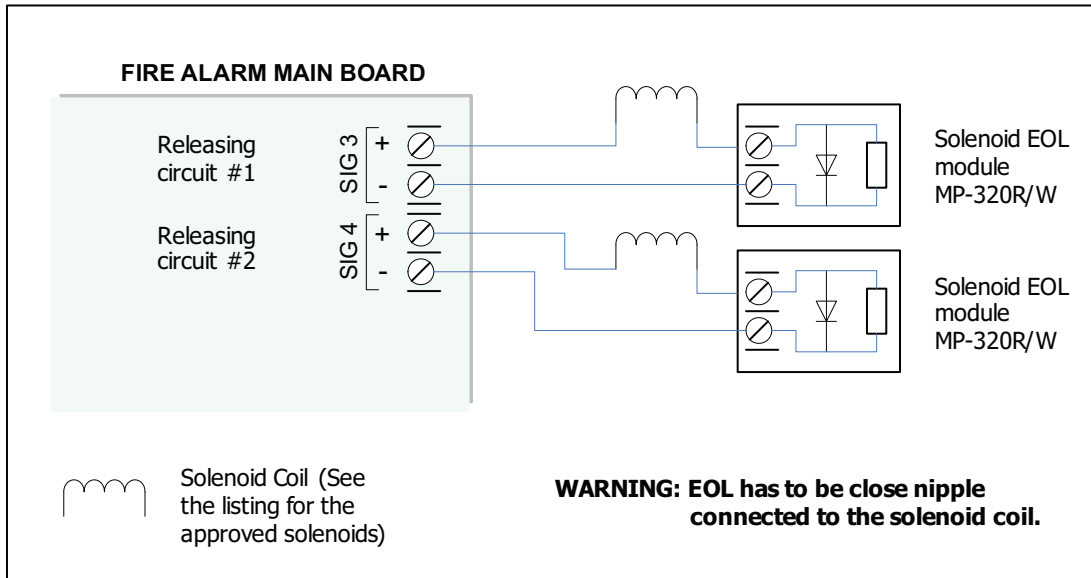

Figure 17 Releasing circuit wiring

## 6.5 Four-Wire Smoke Detector Wiring

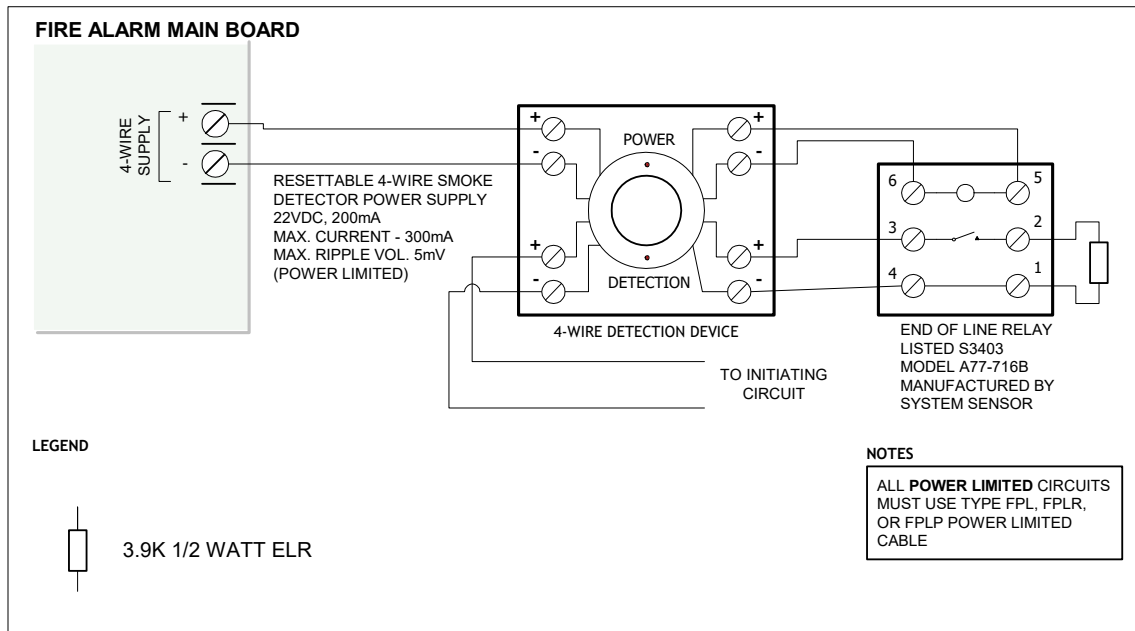

Figure 18 Four-wire smoke detector wiring - class B

## 6.6 Relay Adder Module Wiring

Wire relays on the relay adder module RM-306 as shown in Figure 19.

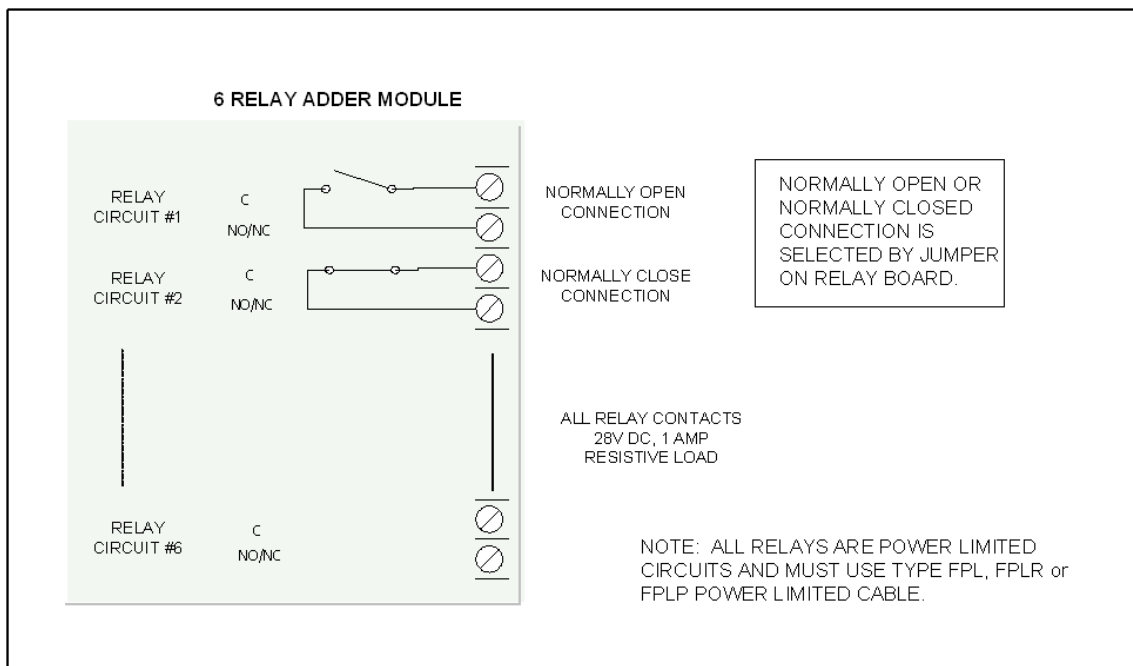

Figure 19 Relay per zone (RM-306) terminal connection

## 6.7 Releasing Circuit Bypass Switch Wiring

According to UL 864 10th edition, the bypass operation must trigger a supervisory alarm. In each mode (section 11) there is a zone designated supervisory. The circuit from the bypass switch shown in Figure 20 must be wired into a designated supervisory zone in the applicable mode.

Use switch: 775103 POTTER 3001002 RCDS-1 RELEASE CIRCUIT DISABLE SWITCH

See Appendix A for the list of compatible solenoids.

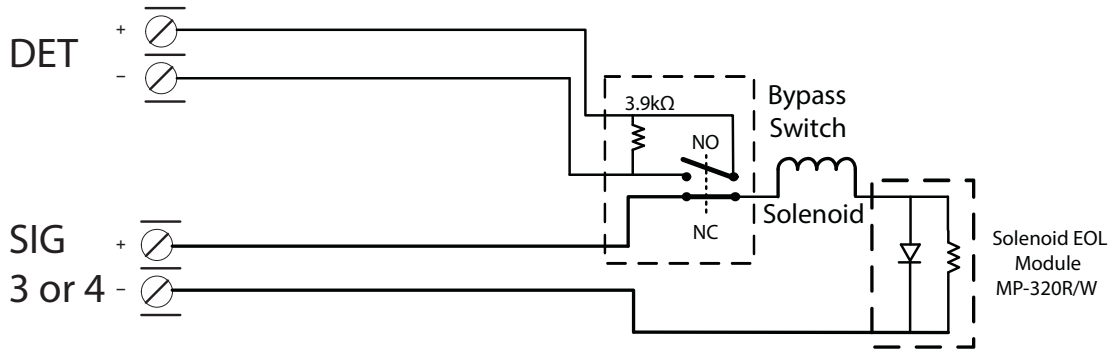

Figure 20 Release Circuit Bypass Switch Wiring

## 6.8 Power Supply Connection

The power supply is part of the Main Chassis. The ratings are:

Table 2 Power Supply Rating

Type	Rating
Electrical Input rating	120 VAC 60Hz 1.75 A / 240 VAC 50 Hz 0.93 A, 10A slow blow fuse on secondary of transformer
Power supply total current	6.5A AC maximum @ secondary of transformer
Battery fuse on Main module	10A, slow blow micro fuse



**Caution:** Do not exceed power supply ratings.

Wire the power supply as shown below using the proper wire gauge.

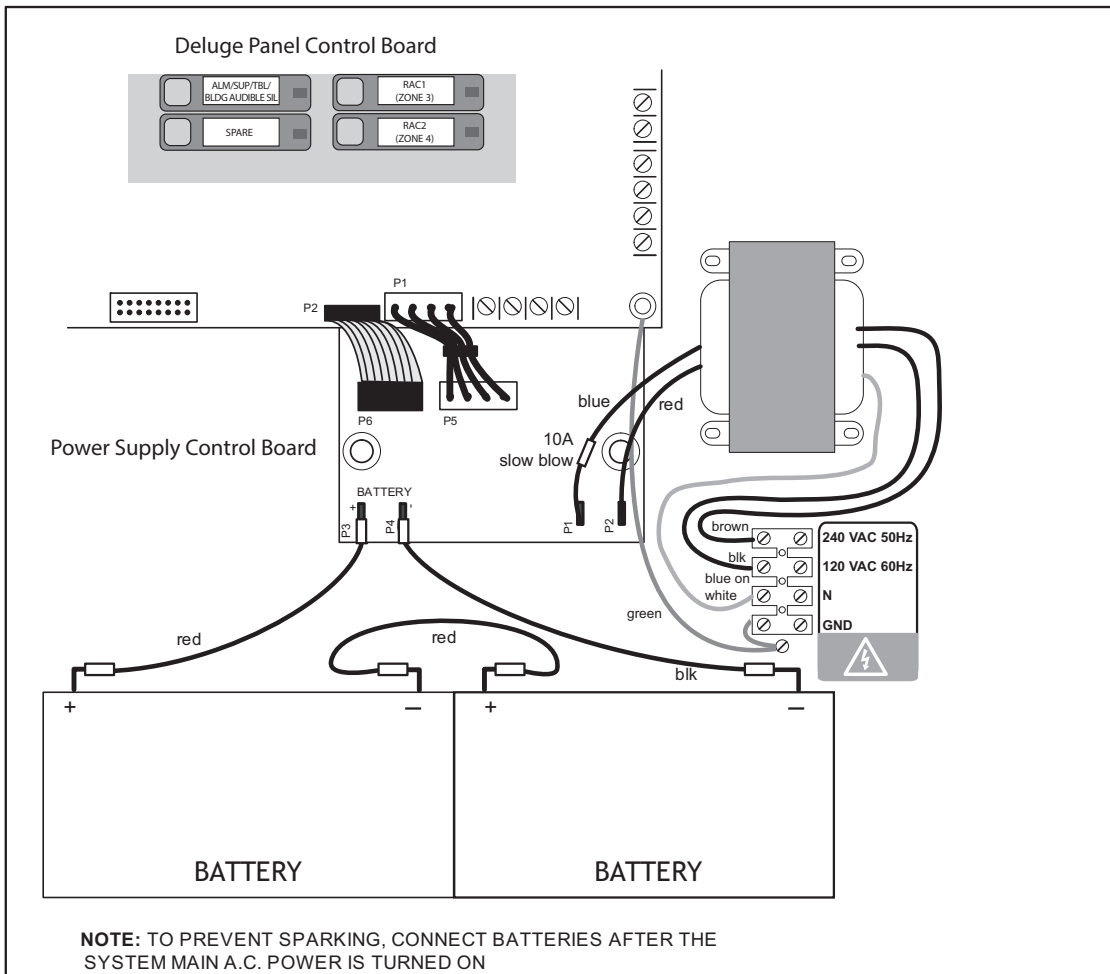

**Figure 21 Power supply connection**

## 6.9 Wiring Tables and Information

The numbers in these tables represent the entire loop length.

**Table 3 Initiating Device Circuit Wiring Distances**

WIRE GAUGE AWG	MAXIMUM WIRING RUN TO LAST DEVICE	
	FEET	METERS
22	2990	910
20	4760	1450
18	7560	2300
16	12000	3600
14	19000	5800
12	30400	9200

*i*

**Notes:** For class A the maximum wiring run to the last device is divided by two.

Maximum loop resistance should not exceed 100  $\Omega$ .

Maximum capacitance of 0.5  $\mu\text{F}$  total on each Initiating Device Circuit.

**Table 4 Notification Appliance Circuit Wiring Distances**

TOTAL SIGNAL LOAD	MAXIMUM WIRING RUN TO LAST DEVICE (ELR)								MAX. LOOP RESISTANCE
	18AWG		16AWG		14AWG		12AWG		
Amperes	ft	m	ft	m	ft	m	ft	m	Ohms
0.06	2350	716	3750	1143	6000	1829	9500	2895	30
0.12	1180	360	1850	567	3000	915	4720	1438	15
0.30	470	143	750	229	1200	366	1900	579	6
0.60	235	71	375	114	600	183	950	289	3
0.90	156	47	250	76	400	122	630	192	2
1.20	118	36	185	56	300	91	470	143	1.5
1.50	94	29	150	46	240	73	380	115	1.2
1.70	78	24	125	38	200	61	315	96	1.0

*i*

**Notes:** For class A wiring the resistance in ohms is multiplied by two.

Maximum voltage drop should not exceed 1.8 volts.

## 6.10 Releasing Circuits

The numbers in this table represent the entire loop length.

**Table 5 Releasing Circuits Wiring Table**

MAXIMUM WIRING RUN TO LAST DEVICE (ELR)						MAX. LOOP RESISTANCE
16AWG		14AWG		12AWG		
ft	m	ft	m	ft	m	Ohms
487	148	774	236	1231	375	3.9

## 6.11 Annunciators

The numbers in this table represent the entire loop length.

**Table 6 RS-485 Wiring to Annunciators and other Devices**

Wire gauge	Maximum wiring run to last device	
AWG	Feet	Meters
22	2000	609.6
20	4000	1219.2
18	8000	2438.4



**Notes:** Use twisted shielded pair,  
300mA power limited.  
Maximum 40  $\Omega$  loop resistance

## 6.12 Four-Wire Smoke Power (regulated)

Four-wire smoke power is provided for four-wire smoke detectors and is rated at 100mA maximum. This filtered supply is supervised therefore a short will disconnect the power and the common trouble is active. The power is reconnected after the 'RESET' key is pressed. See Appendix C for more details.

## 6.13 Supervised Auxiliary Power (regulated)

Supervised auxiliary power is used to power the remote annunciators and smart relay modules and is rated at 300mA maximum. This filtered circuit is supervised therefore a short will disconnect the power and the common trouble is active. The power is reconnected after the 'RESET' key is pressed. See Appendix C for more details.

## 6.14 Unfiltered Supply (full wave rectified)

This unregulated supply is not supervised and is rated at 1.7A maximum. If there is a short on this circuit, the auxiliary power does not recover automatically when the short is removed. This power supply must be disconnected, then reconnected and the panel reset to re-establish the auxiliary power supply. See Appendix C for more details.

## 7.0 System Checkout



**Attention:** In order for the panel to keep accurate logs, it must have the correct time, date, daylight saving time, and time compensation. It is critical to configure these settings on the panel before operation.

**Annual Maintenance Requirement:**

Verify annually that the time, date, daylight saving time, and time compensation are correct. In addition, Mircom recommends keeping a log of when these settings were checked.

See section 9.6.

### 7.1 Before turning the power “ON”

To prevent sparking, **do not connect** the batteries. Connect the batteries after powering the system from the main AC supply.

1. Check that all modules are installed in the proper location with the proper connections.
2. Check all field (external) wiring for opens, shorts, and ground.
3. Check that all interconnection cables are secure, and that all connectors are plugged in properly.
4. Check all jumpers and switches for proper setting.
5. Check the AC power wiring for proper connection.
6. Check that the chassis is connected to **EARTH GROUND** (cold water pipe or ground rod).
7. Make sure to **close the front cover plate** before powering the system from main AC supply.

The best way to check out a panel first is to not connect any field wiring. Power up the panel with all end of line resistors installed. The panel should be free of troubles. Then connect one circuit to field wiring at one time. If a trouble occurs, correct the fault then continue the field wiring.

#### 7.1.1 Measure the Resistance on each Releasing Circuit

Measure the resistance on each releasing circuit to verify that the releasing devices will work. The maximum loop resistance is 3.9  $\Omega$ .

1. Disconnect the wires from the releasing device and from the panel.
2. Short the wires at one end.
3. Connect the other ends of the wires to a voltmeter and measure the resistance of the circuit.

The resistance of the circuit should not exceed 3.9  $\Omega$ . For wiring length and gauges see section 6.10.

#### 7.1.2 Take a Photo of the Circuit Board

Mircom recommends taking a photo of the circuit board during each inspection. This will help confirm the state of the panel at the time of inspection. Mircom recommends sending this photo to the building owner.

## 7.2 Power-up procedure

After completing the System Checkout procedures outlined above,

1. Power up the panel. The "AC ON" green LED and the "Common Trouble" LED should illuminate, and the buzzer should sound. Press the "System Reset" button. Since the batteries are not connected, the trouble buzzer should sound intermittently and the common trouble LED should flash.
2. Connect the batteries while observing correct polarity: the red wire is positive (+) and black wire is negative (-). All indicators should be OFF except for normal power "AC ON" green LED and green LED I4 (below the TROUBLE relay at left bottom of board).



**Note:** Green LED I4 is illuminated when the system is normal. This LED indicates that the trouble relay is in normal standby condition.

3. Configure the Fire Alarm Control Panel as described in the Configuration section.

## 7.3 Troubleshooting

Table 7 Troubleshooting

Symptoms	Possible Cause
Circuit Trouble	To correct the fault, check for open wiring on that particular circuit loop or if the Circuit Disconnect Button is active. <i>Notes: (1) Bypassing a detection circuit or signal circuit will cause a system trouble (off-normal status); (2) Bypassing a releasing circuit will cause a supervisory signal.</i>
Remote Trouble	Remote Trouble will be indicated on the main panel display for any failure reported by, or failure to communicate with a remote annunciator or other remote device.
Ground Fault	This panel has a <b>common ground fault detector</b> . To correct the fault, check for any external wiring touching the chassis or other Earth Ground connection.
Battery Trouble	Check for the presence of batteries and their conditions. Low voltage (below 20.4V) will cause a battery trouble. If battery trouble condition persists, replace batteries as soon as possible.
Common Trouble	If only a common trouble is indicated on the main panel and none of the above confirming trouble indicators are on, check the following for possible fault: <ul style="list-style-type: none"> <li>• Check for any missing interconnection wiring.</li> <li>• Check for any Module missing that was part of the Configuration.</li> <li>• Check for improperly secured cabling.</li> </ul>

# 8.0 Indicators, Controls and Operations

Refer to Figure 22 below for LED indicator and control button locations.

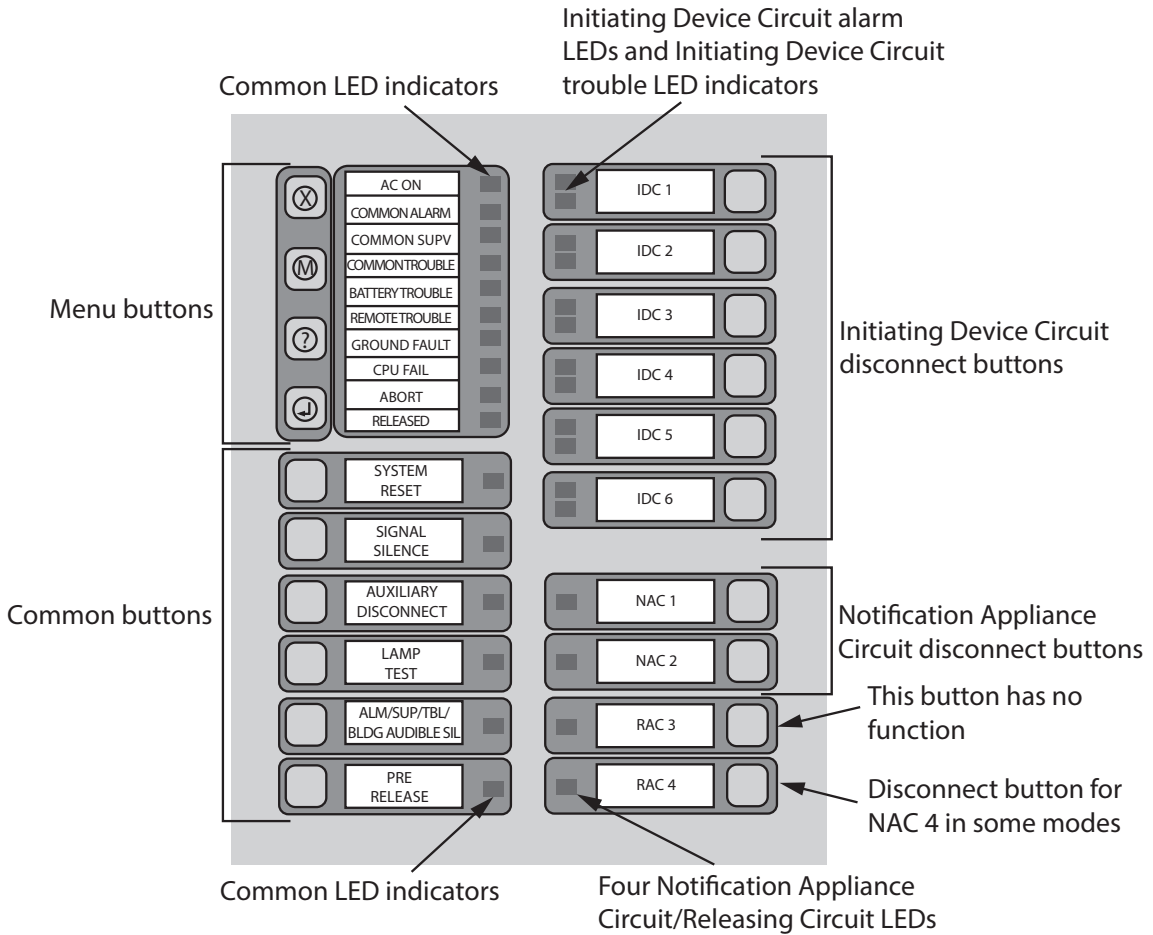

**Figure 22 LED indicators and control buttons**

LED Indicators may be amber, red, or green, and may illuminate continuously (steady), or at one of two flash rates.

- Fast Flash (Supervisory) - 120 flashes per minute, 50% duty cycle
- Trouble Flash (Trouble) - 20 flashes per minute, 50% duty cycle



**Note:** Each display is supplied with laser printer printable paper labels for sliding into the plastic label template on the panel. For the Main Display, the paper label is NP-2056. This includes English and French versions.

## 8.1 Common LED Indicators

### 8.1.1 AC On

The AC ON LED is on steady green while the main AC power is within acceptable levels. It is turned off when the level falls below the power-fail threshold.

### **8.1.2 Common Alarm**

The common alarm LED is illuminated steady red as a result of any active alarm present in the system.

### **8.1.3 Common Trouble**

The common trouble LED is illuminated steady amber as a result of a trouble condition being detected on the system.

### **8.1.4 Battery Trouble**

Flashes amber at a slow rate, when the battery voltage is lower than the specified threshold or the battery is off line. Flashes amber at a fast rate when there is a trouble on the battery charger circuit.

### **8.1.5 Remote Trouble**

Flashes amber at a slow rate as a result of any remote trouble condition.

### **8.1.6 Ground Fault**

Flashes amber at a slow rate when there is a ground fault detected in the system.

### **8.1.7 CPU Fail**

Flashes amber at a slow rate when the CPU is not working properly.

### **8.1.8 Abort**

Illuminate steady amber when the abort circuit is active.

### **8.1.9 Released**

Illuminate steady red when the releasing circuit(s) is active.

### **8.1.10 System Reset**

Turn on steady amber during the system reset process.

### **8.1.11 Signal Silence**

Flashes amber at a slow rate when the signal circuits are silenced.

### **8.1.12 Auxiliary Disconnect**

Flashes amber at a slow rate when the auxiliary disconnect function is active.

### **8.1.13 Lamp Test**

Illuminates amber steady when the lamp test button is pressed.

### **8.1.14 ALM/SUP/TBL/BLDG AUDIBLE SIL (Buzzer Silence)**







Flashes amber at a slow rate when the buzzer is silenced.

### **8.1.15 Pre Release**

Flashes red at a fast rate, when the release timer is started turns off when the release timer expires or the system is reset.

## 8.2 Menu Buttons

To use the menu buttons, install the CFG-300 configuration tool. See section 9.1 for details.

- 
**Menu Button** Pressing  and entering the passcode will allow you to enter the command menu.
- 
**Info Button** When the system is off-normal, press  to display extra information of the event.
- 
**Enter Button** Pressing this button to select a menu option or to confirm a menu operation.
- 
**Cancel Button** To return to previous menu in the configuration or command mode.

## 8.3 Switches and Common Indicators

The FR-320 Series panel is a six-zone panel with four output circuits. The circuits are arranged in the following configuration:

Label on circuit board	Label in Figure 22	Description	Label in the log
DET 1	IDC 1	Initiating Device Circuit 1	Zone-1
DET 2	IDC 2	Initiating Device Circuit 2	Zone-2
DET 3	IDC 3	Initiating Device Circuit 3	Zone-3
DET 4	IDC 4	Initiating Device Circuit 4	Zone-4
DET 5	IDC 5	Manual Release switches or Abort switches or individual switch	Zone-5
DET 6	IDC 6	Manual Release switches or individual switch	Zone-6
SIG 1	NAC 1	Notification Appliance Circuit 1	Output-1
SIG 2	NAC 2	Notification Appliance Circuit 2	Output-2
SIG 3	RAC 3	Releasing Appliance Circuit 3	Output-3
SIG 4	RAC 4	Releasing Appliance Circuit 4 (RAC 4) or Notification Appliance Circuit 4 (NAC 4) in some modes	Output-4

There are 3 Notification Appliance Circuits: NAC 1, NAC 2, and NAC 4. NAC 4 is used in some modes and is numbered to match the label on the circuit board.

There are 2 Releasing Appliance Circuits: RAC 3 and RAC 4. They are numbered to match the labels on the circuit board.

The designations RAC 1, RAC 2 and NAC 3 are not used.

### 8.3.1 IDC 1 to IDC 4

- Alarm LED (red) turns on steady when an alarm is detected
- Supervisory LED (amber) turns on steady when the circuit is active
- Trouble LED (amber) turns on at slow flash rate when in trouble or bypassed

### 8.3.2 IDC 5 and IDC 6

- Alarm LED & Trouble LED      The zone type and LED behavior varies upon the configuration. Steady when turned on.

### 8.3.3 NAC 1 and NAC 2 (NAC Circuits)

- Trouble LED (amber)      turns on at slow flash rate when in trouble or bypassed

### 8.3.4 RAC 3 and RAC 4 (Releasing Circuits)

- Trouble LED (amber)      turns on steady when the circuit is bypassed  
turns on at slow flash rate when in trouble

## 8.4 Circuit (Zone) Disconnect Buttons (Bypass Switches)

Circuit (Zone) Disconnect buttons are provided for all Initiating Device Circuits and Notification Appliance Circuits on the Fire Alarm Control Panel. These buttons are located beside their respective indicating LED. Each button is a toggle switch which disconnects the circuit (if it is currently connected) or connects the circuit (if it is currently disconnected).

The buttons are shown in Figure 22. The Initiating Device Circuit disconnect buttons are labeled **IDC 1-6**. The Notification Appliance Circuit disconnect buttons are labeled **NAC 1** and **NAC 2**. The button labeled **RAC 3** has no function. The button labeled **RAC 4** disconnects NAC 4 in modes where NAC 4 is configured.

Pressing a Circuit Disconnect button bypasses the associated circuit and turns on its Trouble Indicator, activating Common Trouble. While a Circuit is disconnected, all changes in status (alarms and troubles) on that circuit are ignored. The panel does not activate disconnected Notification Appliance Circuits.

Disconnecting an active Latching Initiating Device Circuit (including Alarms, Water flow Alarm, Sprinkler Alarm, General Alarm, and Latching Supervisory) does not affect its status until the panel is reset. Disconnecting an active Non-Latching Initiating Device Circuit (including Non-Latching Supervisory and Trouble-Only) causes them to behave as if the alarm situation has disappeared. Disconnecting an active Notification Appliance Circuit immediately deactivates the circuit.

When an Initiating Device Circuit Disconnect button is returned to the normal (un-bypassed) state (by pressing it again in order to un-bypass the circuit), the panel checks the state of the circuit. If the circuit is active, the Status Indicator flashes for 10 seconds at the Fast Rate without processing the input. If the Circuit is not re-bypassed by then, it will be processed as a new input.

## 8.5 Common Controls

### 8.5.1 System Reset Button

The System Reset button resets the Fire Alarm Control Panel and all Circuits. In particular, the system reset button

- Resets all Latching Trouble Conditions
- Resets all Initiating and Releasing Circuits
- Resets 4-Wire Smoke Supply
- Turns off all Notification Appliance Circuits
- Turns off Signal Silence Indicator if the signal silence option is enabled
- Stops and resets all Timers
- Processes inputs as new events

- Does not affect Aux Disconnect
- Reset cannot be activated until the Signal Silence Inhibit timer has expired

### 8.5.2 Signal Silence Button

Activation of the Signal Silence button when the panel is in alarm turns on the Signal Silence indicator and deactivates any Silenceable Notification Appliance Circuits. Non-Silenceable Circuits are unaffected. Signals will re-sound upon any subsequent alarm. Subsequent operation of signal silence resounds all Silenceable signals. This button does not function during any configured Signal Silence Inhibit Timer period.

### 8.5.3 Auxiliary Disconnect Button

Activating the Auxiliary Disconnect button activates the Auxiliary Disconnect function. The Auxiliary Alarm Relay is always disconnected with this button. The Common Alarm Relay, the Common Supervisory relay and all correlated alarm relays may be disconnected as selected through configuration. Activating the Auxiliary Disconnect button also causes the Common Trouble LED to illuminate steady, the common trouble relay to send a trouble message and the trouble buzzer to flash at the trouble flash rate. Pressing the Auxiliary Disconnect button again de-activates this function and the system will go back to normal.

### 8.5.4 Lamp Test Button

Activation of the Lamp Test button causes all front panel Indicators to steadily illuminate and turns the buzzer ON steady. If Lamp Test is active for more than 10 seconds, Common Trouble is activated.

### 8.5.5 ALM/SUP/TBL/BLDG AUDIBLE SIL Button (Buzzer Silence)

Activation of the ALM/SUP/TBL/BLDG AUDIBLE SIL button while the buzzer is sounding silences the buzzer. The buzzer will resound if there is a subsequent event. Pressing the button when the buzzer is not sounding has no effect.

## 8.6 Common Relays

**Table 8 Common Relays**

Relay Type	Single Hazard	Dual Hazard
Trouble Relay	Trouble	Trouble
Supervisory Relay	Supervisory	Supervisory
Alarm Relay	Alarm	Hazard1 (Alarm)
Aux Alarm Relay	Alarm (Silence-able)	Hazard2 (Alarm)



**Note:** Some troubles are latching once they are detected they remain active until system reset. In this case the common trouble indicator will also remain active until system reset. The common trouble is not bypassed by the auxiliary disconnect function.

## 8.7 Circuit Types

### 8.7.1 Initiating (Detection) Circuit Types

#### 8.7.2 Non-Verified Alarm

A Non-Verified alarm is a “normal” type of alarm that can have pull stations, smoke detectors, or heat detectors attached to it. Activation of any of these devices will immediately result in an alarm condition in the Fire Alarm Control Panel. An Alarm condition causes the associated Circuit Status LED and the Common Alarm LED to illuminate red.

#### 8.7.3 Water Flow Alarm (Water flow Sensors)

Water Flow Alarms are identical to normal Non-Verified Alarms except that any Notification Appliance Circuits programmed to these circuits (all are by default) are Non-Silenceable. Also, if Water Flow Retard Operation is enabled, these circuits are sampled every one second. If ten samples are active within any 15-second interval, the Water flow Alarm is confirmed and processed. An alarm condition causes the associated Circuit Status LED and the Common Alarm LED to illuminate red.



**Note:** Do not use Retard Operation with any external retarding device; maximum retard may not exceed 90 seconds for Canada.

#### 8.7.4 Non-Latching Supervisory (For Supervisory Circuits)

Activation on these circuits will cause the Circuit Status LED and the amber Common Supervisory LED to illuminate. The buzzer will sound at fast rate. If the circuit activation is removed, the Supervisory condition will clear (as long as there are no other Supervisory conditions in the system) and the Circuit Status LED will turn off.

#### 8.7.5 Latching Supervisory (For Supervisory Devices)

Activation on these circuits will cause the Circuit Status LED and the amber Common Supervisory LED to illuminate. The buzzer will sound at fast rate. If the circuit activation is removed, the Supervisory condition will NOT clear.

#### 8.7.6 Abort Switch

When the hazard area is in alarm (pre-discharge) state and the release timer is running, the activation of the corresponding Abort Switch will pause the releasing timer. The release process is held while the Abort Switch is pressed. Releasing the Abort Switch will resume the releasing timer and the corresponding hazard area goes into Alarm (pre-discharge) state again. The value of the release timer after Abort Switch is released depends on the type of Abort Delay in the configuration. When the release timer expires, the corresponding releasing circuit is activated. When the panel is in normal condition, activation of the Abort Switch will cause a trouble signal and the corresponding zone amber LED turns on at slow flash rate.

#### 8.7.7 Manual Release Switch

Activation of the Manual Release Switch of a hazard area will activate the corresponding releasing circuit. If the corresponding Manual Release Delay is non-zero, the releasing circuit will be activated after the Manual Release Delay expires.

## **8.7.8 Notification Appliance Circuit (Signal) Types**

### **8.7.9 Silenceable Signal**

The Silenceable Signal circuit is used for audible devices such as bells and piezo mini-horns that may be silenced either manually or automatically.

### **8.7.10 Non-Silenceable Signal**

The Non-Silenceable Signal Circuit is used for audible devices such as bells and piezo mini-horns that may **not** be silenced either manually or automatically. While sounding, these devices follow the evacuation code pattern that is configured by the installer. For more information on evacuation codes, refer to section 8.8.

### **8.7.11 Silenceable Strobe**

Silenceable strobes will be silenced when the “signal silence” key is pressed.

### **8.7.12 Non-Silenceable Strobes**

Non-Silenceable Strobes will not be silenced when the “signal silence” key is pressed.

## 8.8 Evacuation codes

<b>Continuous</b>	On 100% of the time
<b>Temporal Code</b>	3 of 0.5 second on, 0.5 second off then, 1.5 second pause
<b>20 BPM</b>	1.5 seconds on, 1.5 seconds off
<b>60 BPM</b>	0.5 second on, 0.5 second off
<b>120 BPM</b>	0.25 second on, 0.25 second off

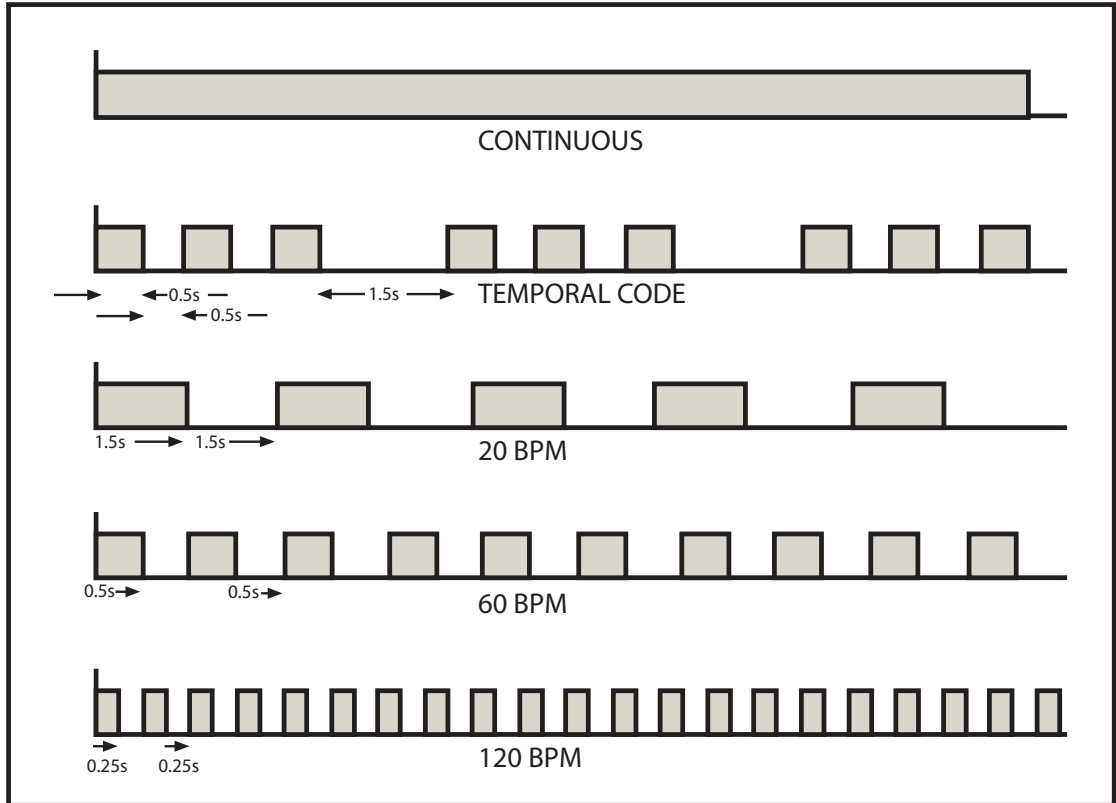

**Figure 23 Evacuation and alert codes**

## 9.0 Configuration

**Table 9 Settings Permitted in CAN/ULCS527**

<b>NOTICE TO USERS, INSTALLERS, AUTHORITIES HAVING JURISDICTION, AND OTHER INVOLVED PARTIES</b>			
This product incorporates field-programmable software. In order for the product to comply with the requirements in CAN/ULCS527, Standard for Control Units for Fire Alarm Systems, certain programming features or options must be limited to specific values or not used at all as indicated below.			
Program feature or option	Permitted in CAN/ULCS527? (Y/N)	Possible settings\methods	Settings permitted in CAN/ULCS527
Temporal pattern in conjunction with manual alarm evacuation control	Y	Modes 1, 2, 3, 4, 5, 6, 7, 8, 9, 10, 11, 12, 13, 14	Mode 11
Abort and manual release on same circuit (unsupervised)	N	Modes 1, 2, 3, 4, 5, 6, 7, 8, 9, 10, 11, 12, 13, 14	None
Abort Delay Type (see page 48)	Y	Standard UL, IRI, NYC, Local Jurisdiction	Standard UL
Manual Signal Silence (see page 50)	Y	Enabled, Disabled	Enabled
Auto Signal Silence Timer (see page 50)	Y	Disabled, 5, 10, 15, 20, 30 minutes	Disabled for NAC circuits for dwelling units
Aux Disconnect disconnects Common Alarm and Common Supervisory (see page 50)	Y	Enabled, Disabled	Disabled
Alarm Transmit Silence (see page 50)	Y	Enabled, Disabled	Disabled
Power Fail Timer (see page 51)	Y	None, 1 hour, 3 hours	None
Signal Isolators (see 11. Sig-Sil. Isol. on page 51)	Y	Enabled, Disabled	Enabled only when suite isolators are used
First Alarm NAC Code (see page 51)	Y	Temporal, 20 BPM	Temporal
Second Alarm NAC Code (see page 51)	Y	Temporal, 60 BPM, 120 BPM	Temporal
Active EOL (see page 52)	Y	Enabled, Disabled	Enabled if using an active EOL resistor or ICAC-306
Supervisory Circuit Type (see page 39)	Y	Latching, Non-latching	Latching

**Table 10 Settings Permitted in UL864**

<b>NOTICE TO USERS, INSTALLERS, AUTHORITIES HAVING JURISDICTION, AND OTHER INVOLVED PARTIES</b>			
This product incorporates field-programmable software. In order for the product to comply with the requirements in UL864, Standard for Control Units and Accessories for Fire Alarm Systems, certain programming features or options must be limited to specific values or not used at all as indicated below.			
Program feature or option	Permitted in UL864? (Y/N)	Possible settings\methods	Settings permitted in UL864
Temporal pattern in conjunction with manual alarm evacuation control	Y	Modes 1, 2, 3, 4, 5, 6, 7, 8, 9, 10, 11, 12, 13, 14	Mode 11
Abort and manual release on same circuit (unsupervised)	N	Modes 1, 2, 3, 4, 5, 6, 7, 8, 9, 10, 11, 12, 13, 14	None
Abort Delay Type (see page 48)	Y	Standard UL, IRI, NYC, Local Jurisdiction	Standard UL
Manual Signal Silence (see page 50)	Y	Enabled, Disabled	Enabled
Signal Silence Inhibit (see page 50)	N	Disabled, 10 seconds, 20 seconds, 30 seconds, 1 minute	Disabled
Aux Disconnect disconnects Common Alarm and Common Supervisory (see page 50)	Y	Enabled, Disabled	Disabled
Alarm Transmit Silence (see page 50)	Y	Enabled, Disabled	Disabled
Power Fail Timer (see page 51)	Y	None, 1 hour, 3 hours	None
Signal Isolators (see page 51)	Y	Enabled, Disabled	Disabled
First Alarm NAC Code (see page 51)	Y	Temporal, 20 BPM	Temporal
Second Alarm NAC Code (see page 51)	Y	Temporal, 60 BPM, 120 BPM	Temporal
Active EOL (see page 52)	Y	Enabled, Disabled	Enabled if using an active EOL resistor ICAC-306

Configure the FR-320 Series Panels using the CFG-300 LCD Tool (see further documentation packaged with CFG-300 for configuration information).

## 9.1 Using the CFG-300 Tool



**Attention:** In order for the panel to keep accurate logs, it must have the correct time, date, daylight saving time, and time compensation. It is critical to configure these settings on the panel before operation.

**Annual Maintenance Requirement:**

Verify annually that the time, date, daylight saving time, and time compensation are correct. In addition, Mircom recommends keeping a log of when these settings were checked.

See section 9.6.

Connect the CFG-300 to the panel, then press (Menu button). The CFG-300 LCD display will display the Main Menu. The function of different buttons on the front panel display is shown in Figure 24 below.

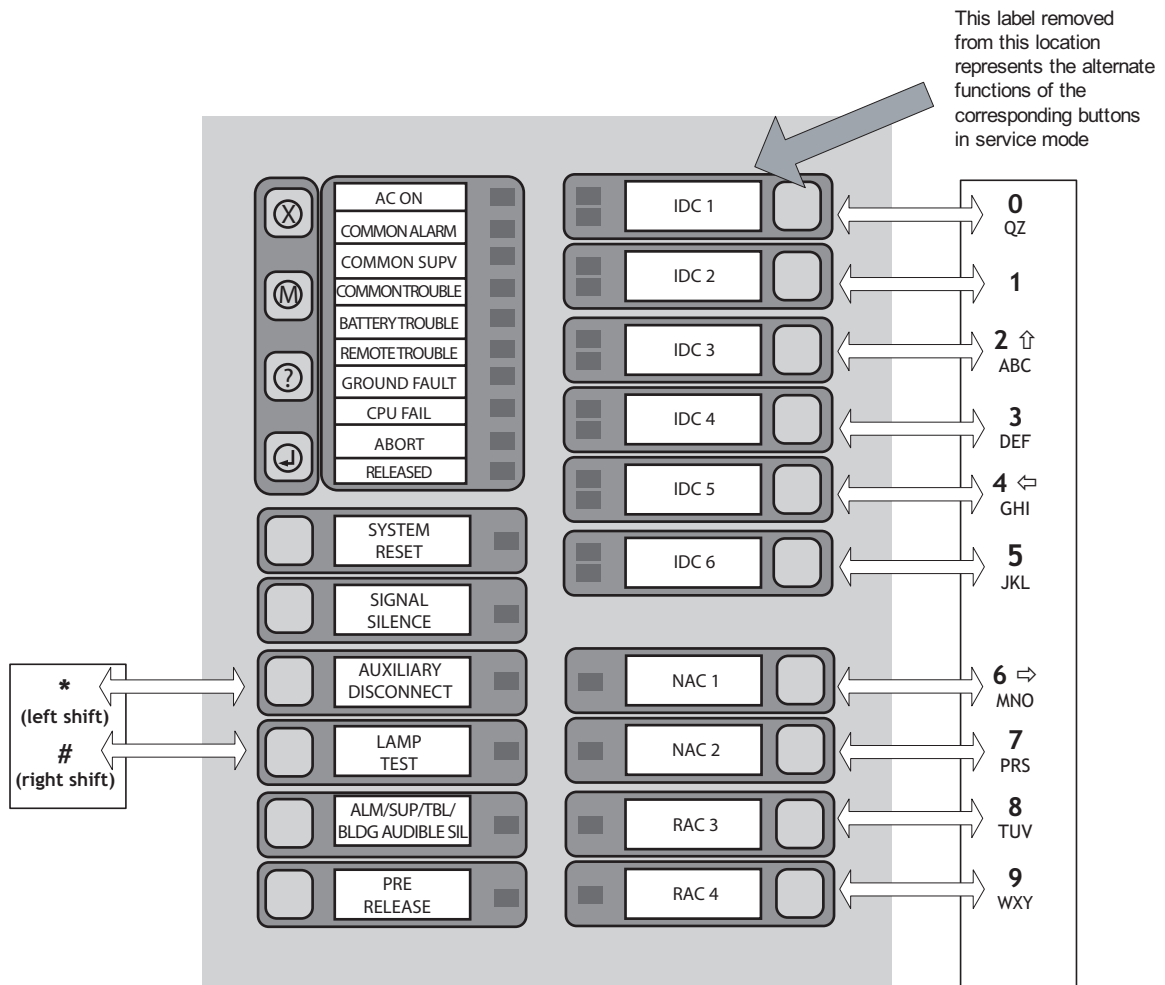



Figure 24 FR-320 Series configuration

## 9.2 Entering the Passcode



**Attention:** Mircom recommends that you change the passwords from the defaults (section 9.7), write them down, and store them in a safe place. If you lose the passwords, you will not be able to access the logs.

The programming section is passcode protected. The following screen shows the message that is displayed to enter the passcode. The maximum allowable passcode is ten digits long, and permits numerical values only. Press  (Enter button) after entering the passcode. If the passcode is correct, it will take you to the main command menu. If the passcode is wrong the system will ask you to re-enter passcode. The system will be exhausted after three retries and will then take you back to the Normal message display.









When the user presses “MENU” and enters the password, they should enter the password of the level intended. If the user is in a lower level of access, attempts to operate functions requiring a higher level of access will be refused. The three levels of access are defined in Table 11.

**Table 11 Access Levels**



Access Level	Description
Level 0 - Command	The default password is for this level “1111” without quotes. In this level the user can only perform regular testing and operation.
Level 1 - Configuration	The default password is for this level “2222” without quotes. User can change configuration and have access to command level.
Level 2 - Factory	Currently not used.

## 9.3 How to Use the Keypad to Program the FR-320 Series

1. Press  (Menu button). You will be prompted to enter your password.
2. Enter your password, then press  (Enter button) to continue.
3. Select a Command Menu option by pressing . The corresponding submenu will display.
4. Use the up and down arrow buttons to scroll through the submenu.
5. Press  to select a submenu option.
6. Use the left or right arrow buttons to select/unselect an option (selected = “X”). Use the up and down arrows to scroll through the different menu options. When entering numerical data, use the up and down arrows to increase or decrease the number.

7. Once you have made the correct selection, press  to confirm the change. The display will return to the submenu screen.
8. Press  (Cancel button) to return to the previous menu.

## 9.4 Command Menu

The main command menu is shown in Figure 25. The first line of the LCD will always show “-Command Menu-”, and the second line scrolls through different selections. Use the “UP” and “DOWN” keys to scroll through the menu, and press the  key to make a selection. To exit from the main command menu, select the “Exit” menu option and then press either the  or  key.



**Note:** Command Menu Item 1 and 6 can only be accessed if jumper JW6 is placed on the main board.

-Command Menu-	Access level Required
1. Panel Config	Configuration
2. Set Time	Configuration
3. Set Password	Configuration
4. View EventLog	Command
5. Print Event Log	Command
6. Clear Event Log	Command
7. Exit	Command

**Figure 25 Command menu**

Pressing “LAMP TEST” at any time will show the information about the system and the software version. The first line shows the panel mode number and pre-programmed mode. The second line shows the software version number. The version of the software is read as Major.Minor.Revision.

## 9.5 1. Panel Config (Command-Menu)

The following is a detailed description of the FR-320 Series configuration menu.



**Note:** Refer to section 9.3 for detailed instructions on making menu selections.

```

-Panel Config-
1. Choose a mode
2. Hazard Config
3. Panel Features
4. Default Config
    
```

### 9.5.1 Command Menu-->Panel Config-->Choose a mode

<p><i>Command Menu--&gt;Panel Config--&gt;Choose a mode</i></p> <p><b>1. Choose a mode</b></p> <pre> Choose a mode: <u>1</u>         </pre>	<p>1--&gt;Default</p>	<p>Use this function to choose a pre-programmed panel configuration. Selections range from modes 1 to 14. Refer to section 11 for details on mode configurations.</p> <p><b>Note: changing the fixed configuration of the panel will cause all configuration data set to default for that particular mode.</b></p>
---	-----------------------	--

## 9.5.2 Command Menu-->Panel Config-->Hazard Config

```
-Hazard Param.-
1. Release timer
2. Abort Delay
3. Manual Rls Delay
4. Soak timer
```



**Note:** Refer to section 9.3 for detailed instructions on making menu selections.

<p><b>Command Menu--&gt;Panel Config--&gt;Hazard Config</b></p> <p><b>1. Release Timer</b></p> <pre>Release timer(sec): 60</pre>	<p>60-&gt;Default</p> <p>Available options: 0, 5, 10, 15, 20, 25, 30, 35, 40, 50, 55, 60 seconds</p>	<p>Use this function to set the programmable timer that delays the activation of the releasing application circuits.</p> <p>This timer starts immediately after receiving a confirming alarm (cross-zoned hazard area) or a single alarm (non-cross-zoned hazard area). When the timer expires, the releasing circuit activates.</p> <p>Value: 0 to 60 seconds in five-second increments.</p>
<p><b>Command Menu--&gt;Panel Config--&gt;Hazard Config</b></p> <p><b>2. Abort Delay</b></p> <pre>Abort Delay Type: [X] Standard UL</pre>	<p><input checked="" type="checkbox"/> Standard UL-&gt;Default</p> <p><input type="checkbox"/> IRI</p> <p><input type="checkbox"/> NYC</p> <p><input type="checkbox"/> Local Juris.</p>	<p>Use this function to set how the Abort Switch operates with the Release Timer.</p> <p>Note that if the Release Timer is set to zero, the Abort Switch does not operate.</p> <p>In standard UL mode, after the Abort switch is pressed, the release timer will reset and then restart. If the switch is held for any time up to 50 seconds, then the releasing device will actuate 60 seconds after the switch is pressed. However, if the switch is held for longer than 50 seconds, then the releasing device will actuate 10 seconds after the switch is released.</p> <p>In <b>IRI</b> (Industrial Risk Insurers) mode, the switch works in the same way as it does in Standard UL mode, except that the switch will function only if it is pressed and held before the second alarm comes in. The release occurs 10 seconds after the Abort Switch is restored.</p> <p>In <b>NYC</b> (New York City) mode, pressing the Abort Switch will reset to the Release Timer and add 90 seconds to the configured timer duration. After the Abort Switch is released, the Release Timer will restart.</p> <p>In <b>Local Juris.</b> (Local Jurisdiction Delay), pressing the Abort Switch will reset the Release Timer back to its configured value. After the switch is released, the Release Timer will restart.</p>

<p><b>Command Menu--&gt;Panel Config--&gt;Hazard Config</b></p> <p><b>3. Man. Rls Delay</b></p> <div style="border: 1px solid gray; padding: 5px; background-color: #f0f0f0;"> <p>Man. Rls Delay(sec):</p> <p><u>0</u></p> </div>	<p>0-&gt;Default</p> <p>Available options:</p> <p>0, 5, 10, 15, 20, 25, 30 seconds</p>	<p>Use this function to set the time delay of activation of corresponding releasing circuit(s) after activation of the manual release switch.</p> <p>Value: 0 to 30 seconds in five-second increments.</p>
<p><b>Command Menu--&gt;Panel Config--&gt;Hazard Config</b></p> <p><b>4. Soak timer</b></p> <div style="border: 1px solid gray; padding: 5px; background-color: #f0f0f0;"> <p>Soak timer (sec):</p> <p><u>0</u></p> </div>	<p>0-&gt;Default (continuous)</p> <p>The selectable values are in seconds: 0, 10, 20, 30, 40, 50, 60, 120(2min), 180(3min), 240(4min), 300(5min), 360(6min), 420(7min), 480(8min), 540(9min), 600(10min), 660(11min), 720(12min), 780(13min), 840(14min), 900(15min)</p>	<p>Use this function to set the length of time for which the releasing circuit is active. When the soak timer expires, the control panel automatically shuts off the activated releasing circuit.</p> <p>0 seconds means that the soak timer is disabled and the releasing circuit is active continuously.</p>





### 9.5.3 Command Menu-->Panel Config-->Features

-Panel Features-

1. Man. Sig. Sil
2. Wtr/Sprk. Retd
3. Aux Dis Corr
4. Sig-Sil Inh Tm
5. Aux Dis Alm&Sv
6. Auto Sil. Tmr
7. Rem. Annun.
8. Alm. Xmit. Sil.
9. Pwr Fail Tmr.
10. Com. Supv. Rly
11. Sig. Sil. Isol.
12. 1st Alarm Code
13. 2nd Alarm Code
14. Supv. Latching
15. Supv on NAC-2
16. Sig-Sil NAC

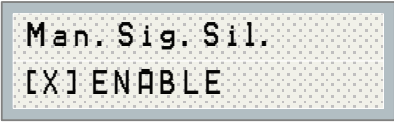
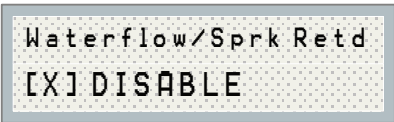

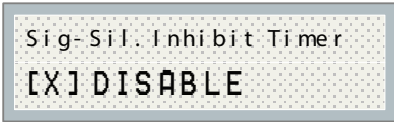
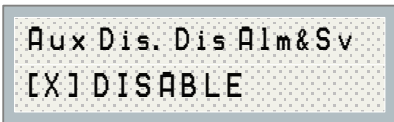
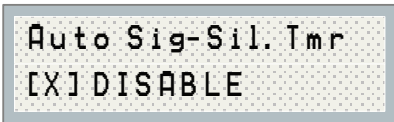
**Note:** Refer to section 9.3 for detailed instructions on making menu selections.

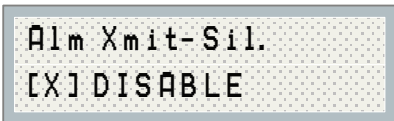
<p><i>Command Menu--&gt;Panel Config--&gt;Features</i></p> <p><b>1. Manual Sig. Silence</b></p> 	<p><input checked="" type="checkbox"/> ENABLE --&gt;Default  <input type="checkbox"/> DISABLE</p>	<p>Use this function to enable or disable the Signal Silence operation on the panel.</p>
<p><i>Command Menu--&gt;Panel Config--&gt;Features</i></p> <p><b>2. Wtr/Sprk. Retd</b></p> 	<p><input type="checkbox"/> ENABLE  <input checked="" type="checkbox"/> DISABLE--&gt;Default</p>	<p>By default all the Initiating Device Circuits configured as waterflow or sprinkler act as non-verified alarms. If enabled, a retard operation is performed for Initiating Device Circuits configured as waterflow or sprinkler. The maximum retard may not exceed 90 seconds for Canada.</p>
<p><i>Command Menu--&gt;Panel Config--&gt;Features</i></p> <p><b>3. Aux Dis Corr</b></p> 	<p><input checked="" type="checkbox"/> ENABLE --&gt;Default  <input type="checkbox"/> DISABLE</p>	<p>By default this function will disconnect the auxiliary alarm relay when the aux disconnect button is pressed. If enabled, this function will disconnect the auxiliary alarm relay <i>and</i> all correlated relays when the aux disconnect button is pressed.  <b>Correlated relays include:</b> RM-306 and SRM-312W.</p>
<p><i>Command Menu--&gt;Panel Config--&gt;Features</i></p> <p><b>4. Sig-Sil Inh Tmr</b></p> 	<p><input checked="" type="checkbox"/> DISABLE--&gt;Default  <input type="checkbox"/> 10sec  <input type="checkbox"/> 20sec  <input type="checkbox"/> 30sec  <input type="checkbox"/> 1min</p>	<p>Use this function to inhibit the signal silence switch for a desired length of time. The time period should expire before the signals may be silenced. According to the Canadian National Building Code, this timer should be set to one minute.</p>
<p><i>Command Menu--&gt;Panel Config--&gt;Features</i></p> <p><b>5. Aux. Dis. Dis Alam&amp;Sv</b></p> 	<p><input type="checkbox"/> ENABLE  <input checked="" type="checkbox"/> DISABLE--&gt;Default</p>	<p>If enabled the Common Alarm and Common Supervisory relays will be disconnected when Aux. Disconnect is pressed. If disabled, the Aux disconnect switch has no effect on the Common Alarm relay, the Common Supervisory relay.</p>
<p><i>Command Menu--&gt;Panel Config--&gt;Features</i></p> <p><b>6. Auto Sig-Sil. Tmr</b></p> 	<p><input checked="" type="checkbox"/> DISABLE--&gt;Default  <input type="checkbox"/> 5 Min  <input type="checkbox"/> 10 Min  <input type="checkbox"/> 20 Min  <input type="checkbox"/> 30 Min</p>	<p>Use this function to set the time period for which the Notification Appliance Circuits will sound before they are automatically silenced.</p>
<p><i>Command Menu--&gt;Panel Config--&gt;Features</i></p> <p><b>7. Rem. Annun.</b></p> 	<p><input checked="" type="checkbox"/> NONE--&gt;Default  <input type="checkbox"/> 1  <input type="checkbox"/> 2          ...  <input type="checkbox"/> 6</p>	<p>Use this function to program the number of remote annunciators. Any combination of remote annunciators or smart relays can be used as long as the number does not exceed 6. The annunciators' addresses should be linear: without gaps and in sequence.</p>
<p><i>Command Menu--&gt;Panel Config--&gt;Features</i></p> <p><b>8. Alarm Xmit-Sil.</b></p> 	<p><input type="checkbox"/> ENABLE  <input checked="" type="checkbox"/> DISABLE--&gt;Default</p>	<p>Use this function to allow the alarm transmit and auxiliary alarm relay to reset on the Signal Silence rather than the Reset switch.</p>

<p><i>Command Menu--&gt;Panel Config--&gt;Features</i></p> <p><b>9. Pwr Fail Tmr</b></p> <pre>AC Pwr Fail Dly Tmr. [X] None</pre>	<p><input checked="" type="checkbox"/> NONE-&gt;Default  <input type="checkbox"/> 1 HRS  <input type="checkbox"/> 3 HRS</p>	<p>Use this function to delay the reporting of AC power fail trouble for a specific time period. If disabled, the AC power fail will be reported immediately.</p>
<p><i>Command Menu--&gt;Panel Config--&gt;Features</i></p> <p><b>10. Com. Supv. Rly</b></p> <pre>Common Supv. Relay [X] ENABLE</pre>	<p><input type="checkbox"/> ENABLE  <input checked="" type="checkbox"/> DISABLE-&gt;Default</p>	<p>If enabled, the common supervisory relay can be used as a common alarm relay. It will act the same way as a common alarm relay. If disabled, it is used as a common supervisory relay.</p>
<p><i>Command Menu--&gt;Panel Config--&gt;Features</i></p> <p><b>11. Sig-Sil. Isol.</b></p> <pre>Sig-Sil. Isol. [X] DISABLE</pre>	<p><input type="checkbox"/> ENABLE  <input checked="" type="checkbox"/> DISABLE-&gt;Default</p>	<p>Enable this function only when suite isolators are used (Canada only).</p>
<p><i>Command Menu--&gt;Panel Config--&gt;Features</i></p> <p><b>12.1st Alarm NAC Code</b></p> <pre>1st Alarm NAC Code [X] Temporal</pre>	<p><input checked="" type="checkbox"/> Temporal -&gt;Default  <input type="checkbox"/> 20 BPM</p>	<p>Sets the NAC indicating code when the 1st alarm comes in.</p>
<p><i>Command Menu--&gt;Panel Config--&gt;Features</i></p> <p><b>13. 2nd Alarm NAC Code</b></p> <pre>2nd Alarm NAC Code [X] 120 BPM</pre>	<p><input checked="" type="checkbox"/> 120 BPM-&gt;Default  <input type="checkbox"/> 60 BPM  <input type="checkbox"/> Temporal</p>	<p>Choose the NAC indicating code when the 2nd alarm comes in.</p>
<p><i>Command Menu--&gt;Panel Config--&gt;Features</i></p> <p><b>14. Supv. Latching</b></p> <pre>Supervisory Latching [X] Non-latching</pre>	<p><input type="checkbox"/> Latching  <input checked="" type="checkbox"/> Non-latching-&gt;Default</p>	<p>Use this function to set the supervisory circuit as either latching or non-latching.  NOTE: For ULC operation the supervisory should be programmed as latching</p>
<p><i>Command Menu--&gt;Panel Config--&gt;Features</i></p> <p><b>15. Supv on NAC-2</b></p> <pre>Supv. Alert on NAC-2 [X] DISABLE</pre>	<p><input type="checkbox"/> ENABLE  <input checked="" type="checkbox"/> DISABLE-&gt;Default</p>	<p>Use this function to enable/disable the supervisory circuit indication on NAC-2.</p>
<p><i>Command Menu--&gt;Panel Config--&gt;Features</i></p> <p><b>16. Sig-Sil NAC</b></p> <pre>Silenceable NAC [X] NAC-1</pre>	<p><input checked="" type="checkbox"/> NAC-1-&gt;Default  <input checked="" type="checkbox"/> NAC-2-&gt;Default</p>	<p>Use this function to set which NAC circuits are silenceable or non-silenceable.</p>

<p><i>Command Menu--&gt;Panel Config--&gt;Features</i></p> <p><b>17. Active EOL</b></p> <div style="border: 1px solid gray; padding: 5px; width: fit-content;"> <p>Active EOL [X] DISABLE</p> </div>	<p>[X] DISABLE--&gt;Default [ ] ENABLE</p>	<p>Enable this function if you are using an active EOL resistor or ICAC-306 (ICAC-306 has built in Active EOL resistors).</p>
--	--	---

### 9.5.4 Command Menu-->Panel Config-->Default Config

<p><i>Command Menu--&gt;Panel Config--&gt;Default Config</i></p> <p><b>4. Default Config</b></p> <div style="border: 1px solid gray; padding: 5px; width: fit-content;"> <p>Load the default Settings? <u>Y</u></p> </div>	<p>Y--&gt;Default</p>	<p>Use this function to reset the panel to the default configuration of the chosen programming mode.</p>
--	-----------------------	--

## 9.6 2. Set Time (Command-Menu)



**Attention:** In order for the panel to keep accurate logs, it must have the correct time, date, daylight saving time, and time compensation. It is critical to configure these settings on the panel before operation.

**Annual Maintenance Requirement:**

Verify annually that the time, date, daylight saving time, and time compensation are correct. In addition, Mircom recommends keeping a log of when these settings were checked.

See section 9.6.



**Note:** Refer to section 9.3 for detailed instructions on making menu selections.

1. Daylight Save
  2. Time Clock
  3. Compensation

<p><i>Command Menu--&gt;Set Time</i></p> <p><b>1. Daylight saving time</b></p> <div style="border: 1px solid gray; padding: 5px; width: fit-content;"> <p>Daylight Saving [X] Disable</p> </div>	<p>[X] DISABLE -&gt;Default [ ] ENABLE</p>	<p>Use this function to enable daylight savings time.</p>
<p><i>Command Menu--&gt;Set Time</i></p> <p><b>2. Set time and date</b></p> <div style="border: 1px solid gray; padding: 5px; width: fit-content;"> <p>HH:MM WKD YYYY-MM-DD 00:00 MON 2000-01-01</p> </div>	<p>Default 00:00 MON 2000-01-01</p>	<p>Use this function to set the time and date. Use the "LEFT" and "RIGHT" keys to move the cursor to the desired location in the display and use the "UP" and "DOWN" keys to increase or decrease the values. Press the "ENTER" key to accept the changes and the "CANCEL" key to ignore the changes.</p> <p><b>Note:</b> time is in 24hr format</p>

**Command Menu-->Set Time**

## 2. Compensation

```
HH:MM WKD YYYY-MM-DD
```

```
00:00 MON 2000-01-01
```

When value is entered the following message will appear

```
Daily Compen. (Sec):
```

```
Panel Config Updated
```

Default: 0 seconds (no compensation)

Compensation values range from -15.0 to +15.0 seconds. The increment is a tenth of a second.

Use the Up and Down arrow keys to select the daily compensation value and press ENTER.

**For a fast clock, make the compensation negative (-). For a slow clock, make the compensation positive (+).**

Use the up and down arrow keys to change the seconds, and use the right and left arrow keys to change the tenths of a second. For example, to change the value from 0 to -5.5, use the down arrow key to select **-5.0**, then use the right arrow key to select **-5.5**.

### How to calculate the compensation

Take note of how many seconds the panel clock has drifted after 30 days, then divide this number by 30 to calculate the average daily drift. For example, make a note of the time at the beginning of the month, and then again 30 days later. If the clock is 165 seconds fast after 30 days, change the compensation to -5.5 seconds.

$$165 \div 30 = 5.5$$

If the clock is 100 seconds slow after 30 days, change the compensation to +3.3 seconds.

$$100 \div 30 = 3.3$$

### Time Clock Adjust trouble

A **Time Clock Adjust** trouble appears every time the panel restarts, as a reminder to set the time compensation. The trouble also appears 365 days after the last time that the clock was adjusted. To clear the trouble, adjust the time compensation.

## 9.7 3. Set Password (Command-Menu)



**Note:** Refer to section 9.3 for detailed instructions on making menu selections.



**Attention:** Mircom recommends that you change the passwords from the defaults, write them down, and store them in a safe place. If you lose the passwords, you will not be able to access the logs.

<p><b>Command Menu--&gt;Set Password</b> First choose the level of password to be changed</p> <div style="border: 1px solid gray; padding: 5px; margin-bottom: 10px;"> <p>Select Access Level</p> <p>0</p> </div> <p>Then</p> <div style="border: 1px solid gray; padding: 5px; margin-bottom: 10px;"> <p>Enter new passcode:</p> </div> <div style="border: 1px solid gray; padding: 5px; margin-bottom: 10px;"> <p>Re-enter new passcode:</p> </div> <p>If the passcode does not match, the following message appears and the system exit to the main menu.</p> <div style="border: 1px solid gray; padding: 5px; margin-bottom: 10px;"> <p>Invalid passcode</p> </div> <p>If the passcode is OK the following message appears and exits to the main menu.</p> <div style="border: 1px solid gray; padding: 5px;"> <p>Passcode updated</p> </div>	<p>0 -&gt; Default</p>	<p>Use this function to change the passcode. The minimum number of digits is 4 and the maximum is 10. Only numeric digits are allowed.</p>
---	------------------------	--

The user can change the password only for the current access level as well as any lower levels.

## 9.8 4. View Event Log (Command-Menu)

The event log looks the same as the normal event queue. Pressing the “INFO” key has the same effect that it does in the event queue. The illustration below provides an example of how

the "INFO" key works and shows the CFG-300 LCD Configuration tool display.

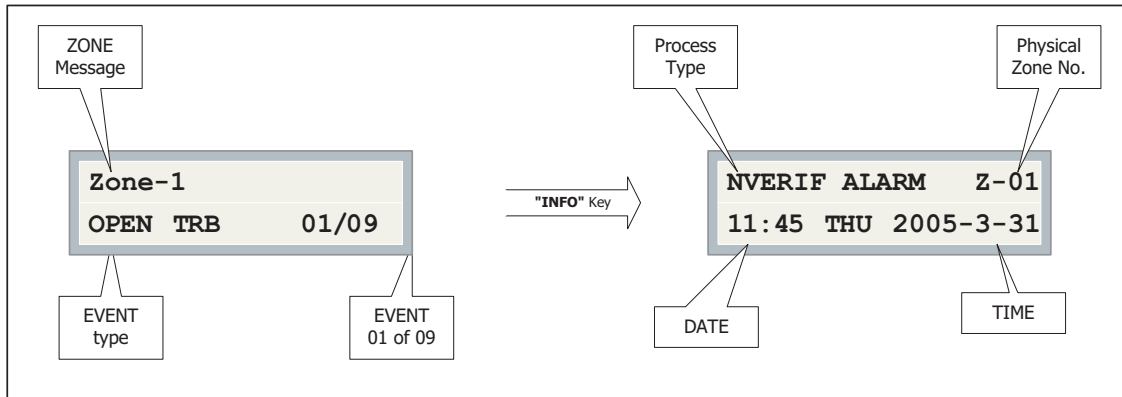

**Figure 26 Event log**

There are a maximum of 200 recent events saved in the event log. If the number of events goes beyond 200, the oldest event is overwritten by the most recent one.

## 9.9 5. Print Event Log

**Command Menu-->Print Event Log**

```
-Event Logs-
1. Alarm Log
2. General Log
```

Use this function to print the Alarm or General log.

Select the type of log to print. Press the "ENTER" key. The system will then print the requested log

### 9.9.1 Print the alarm log

You need:

- Windows 7, 10 or 11
- Tera Term software application
- Mircom's MGC-CONFIG-KIT4

#### Connect the computer to FR-320 Series

- Connect the computer to the P7 connector on the main FR-320 Series board.

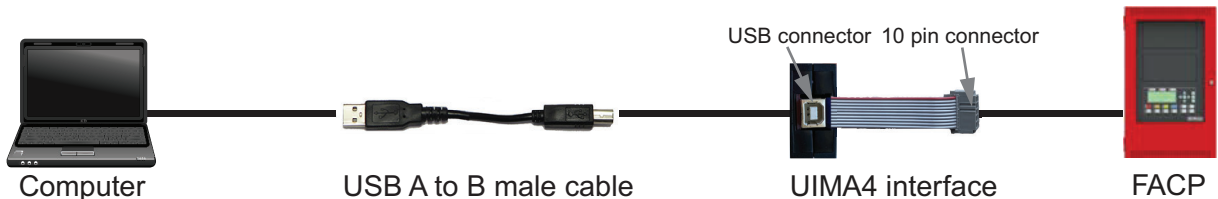

**Figure 27 Connect the computer to the P7 connector on the main FR-320 Series board**

## Configure Tera Term

1. Start the Tera Term application.

The **New connection** window appears.



**Figure 28 Tera Term New connection**

2. Select **Serial**.
3. In the **Port** menu, select the COM port that the USB cable is using.
4. Click **OK**.
5. Click **Setup**, and then click **Serial port**.

The **Serial Port Setup** window appears.

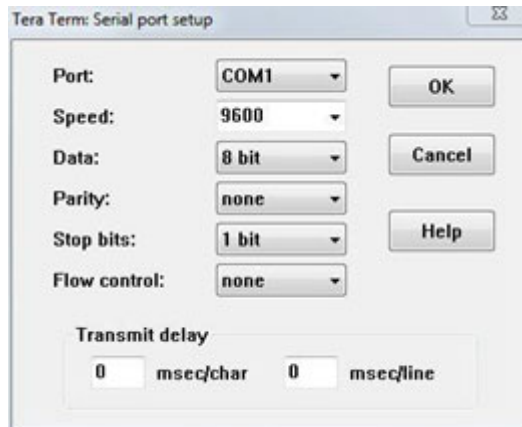

**Figure 29 Tera Term Serial port setup**

6. Select the correct COM port.
7. Select **9600** as the **Speed**.
8. Click **OK**.

## Print the alarm log or general log

1. On the CFG-300 display, access the **Menu** and select **Print Event Log**.
2. Select **Alarm Log** or **General Log**, then press the Enter key.

The panel prints the log to the virtual terminal program. An example general log is shown in Figure 30.

```

----- General Log Report - 09:55:54 2023-04-13 -----
Command menu      activated
                  09:55:34 2023-04-13

System reset      complete
Trb:0x06 Info:0x000009:01:21 2023-04-13

Output-4          Restored
RAC               Z-4 09:01:16 2023-04-13

Output-3          Restored
RAC               Z-3 09:01:16 2023-04-13

Output-2          Opt restored
SIL SIGNAL        Z-2 09:01:16 2023-04-13

Output-1          Opt restored
SIL SIGNAL        Z-1 09:01:16 2023-04-13

System reset      in process
Trb:0x06 Info:0x000009:01:16 2023-04-13

Output-4          Activated
RAC               Z-4 09:01:03 2023-04-13

Output-3          Activated
RAC               Z-3 09:01:03 2023-04-13

Zone-2            Alarm
NON-VERIF ALARM  Z-2 09:00:04 2023-04-13

Output-2          Opt active
SIL SIGNAL        Z-2 08:59:56 2023-04-13

Output-1          Opt active
SIL SIGNAL        Z-1 08:59:56 2023-04-13

```

**Figure 30 Example event log printout**

## 9.10 6. Clear Event Log (Command-Menu)



**Note:** Refer to section 9.3 for detailed instructions on making menu selections.

### Command Menu-->Clear Event Log

-Select Log-

1. Alarm Log
2. General Log
3. All Logs

Select the type of log to clear. Press the "ENTER" key. The system will then confirm before clearing logs.

Clear all the  
Selected log(s)? Y

Press the "ENTER" key to confirm or the "CANCEL" key to cancel the operation.

Log(s) cleared

Use this function to clear alarm logs, event logs, or both.

## 9.11 7. Exit (Command-Menu)

Pressing, "ENTER" after selecting "Exit" from the menu will return the panel to normal LCD operation.

## 10.0 Operating the Panel

### 10.1 Panel Operation During Various Hazard States

The escalating hazard zone states include Idle, Alert, Alarm and Release. They are defined based on the status of Hazard Area input zone(s), correlated Abort Switch and Manual Release Switch.

#### 10.1.1 Hazard Idle

- No correlated alarm zone active.
- Release Timer is not started.
- Manual Release Delay Timer is not started.
- Abort Switch is off.
- Manual Release Switch is off.
- Corresponding NAC circuit is off.
- Releasing circuit(s) is off.

#### 10.1.2 Hazard Alert (or equivalently first Alarm in Cross-zoned Application)

- The panel enters the Hazard Alert state when
  - a single alarm comes in for a cross-zoned hazard. For non cross-zoned hazard area, a single alarm will put hazard into Hazard Alarm state directly.
  - the Abort Switch becomes active during Hazard Alarm state, so that the hazard area state downgrades from Hazard Alarm to Hazard Alert.
- Release Timer is not started.
- Manual Release Delay Timer is not started.
- Correlated NAC circuit(s) turns on at alert rate.

#### 10.1.3 Hazard Alarm (pre-discharge, or equivalently second Alarm in Cross-zoned Application)

- The panel enters the Hazard Alarm state when
  - it detects the confirming alarm for hazard area (single alarm active for the non cross-zoned system, or 2nd alarm active in the cross-zoned system), or
- Manual Release Switch is active.
- Release Timer (RT) is started when the panel enters Hazard Alarm state after by detecting the 2nd alarm in cross-zoned hazard or 1st alarm in non cross-zoned hazard. The Release Timers are shown on the CFG-300 and RAM-300LCDR display; see Figure 31 and Figure 32.
- Manual Release Delay Timer is started when the panel enters Hazard Alarm state by detecting the correlated Manual Release Switch active.
- Releasing circuit(s) will be activated after the Release Timer or Manual Release Timer expires.
- Corresponding NAC(s) turns on at alarm rate.
- During Hazard Alarm State, when the release timer is running and the Abort Switch turns on, the hazard area state will change from Hazard Alarm to Hazard Alert. Release Timer is held and the corresponding NAC sounds the Alert rate. If the Abort Switch is released, the hazard state will go back to Hazard Alarm and the Release Timer resumes

running. The value of release timer depends on Abort Delay Type. The corresponding NAC sounds Alarm rate again.

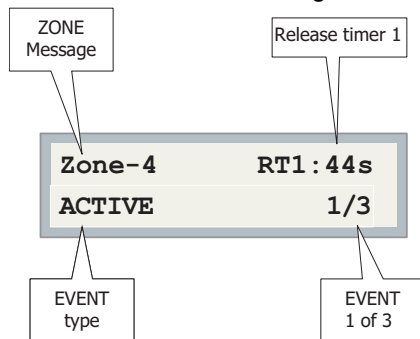

**Figure 31 1 release timer active**

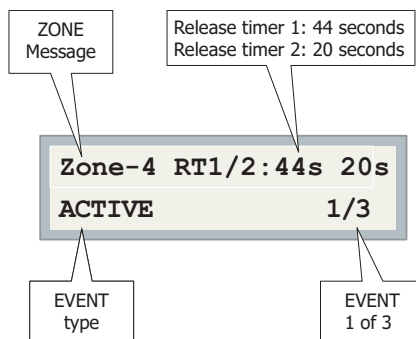

**Figure 32 2 release timers active**

### 10.1.4 Hazard Release

- Panel enters Hazard Release when the Release Timer or Manual Release Timer expires. The correlated releasing circuit is activated.
- NAC code for Hazard Release state is steady.

## 10.2 General Panel Operation

- Activation of Manual Release Switch starts the Manual Release Delay Timer. The expiration of Manual-release Delay Timer (MDT) activates the releasing circuits consequently. Manual Release Switch overrides the Abort Switch always and Manual-release Timer (MDT) always overrides Release Timer (RT).
- When the manual release switch is active and the panel is in the Hazard Alarm (pre-discharge) state, Abort Switch cannot override the Manual Release Switch. Only the System Reset key can interrupt and reset the panel and hazard area.
- System Reset will reset all circuits, including releasing circuits.
- The supervisory circuit can be optionally indicated on NAC-2 circuit. The NAC code of supervisory circuit should be different from those of Hazard Alert or Hazard Alarm. By default, when the NAC code for Hazard Alert is Temporal, the NAC code for supervisory circuit is 20 BPM or verse visa. This configuration change is automatically done by the panel. If NAC code for alert is chosen other than 20 BPM and Temporal, Supervisory NAC code will remain unchanged during the configuration.
- In some pre-programmed modes, the Alert Rate and the Alarm Rate are configured the same. So the action of Abort Switch does not change the NAC rate.

- To avoid the conflict of different NAC code on the same circuit, the priority of signals are defined as, Water-flow alarm has the highest priority, then hazard cadence. The supervisory signal has the lowest priority.
- Soak Timer sets the time period how long the releasing circuits should be active. Upon the expiration of soak timer, the releasing circuits will be shut off. Setting of 0 second means the releasing circuits will be turned on without timer running. They will be shut off upon system reset.
- Abort function is not applicable in pre-action and deluge application.

# 11.0 Pre-Programmed Modes

See tables 9 and 10 for permitted ULC and UL settings.

This section uses the following abbreviations.

Z1 - Z6	Initiating Device Circuits 1 to 6 (also referred to as Input Zones) marked DET 1 to DET 6 on circuit board
Out1 - Out4	Notification Appliance Circuits marked SIG 1 to SIG 4 on circuit board Out1 and Out2 are equivalent to NAC 1 and NAC 2 Out3 is equivalent to RAC 3 Out4 is either RAC 4 or NAC 4 depending on the mode See section 8.3
Zp	Phantom zone
RT1	Releasing timer 1
RT2	Releasing timer 2
Tmr	Timer
RLS	Releasing
Alm	Alarm
WF	Waterflow
Supv	Supervisory input circuit
AB	Abort input circuit
MR	Manual Release input circuit
Exp	Expired

## 11.1 Mode 1: Agent Release, Single Hazard, Cross-zoned, Combined Release

			Detection Zones						Phantom Zones		Release Timers	
			Z1	Z2	Z3	Z4	Z5	Z6	Zp1	Zp2	RT1 Exp	RT2 Exp
			Alm	Alm	WF	Sup	AB	MR	Z1+Z2	Z3+Z4		
<b>Out1</b>	Signal	Steady	X	X	X			X				
<b>Out2</b>	Signal	Escalating			X	(X)		X	X			
<b>Out3</b>	Rel.	Releasing						X			X	
<b>Out4</b>	Rel.	Releasing						X			X	
<b>RLS TMR 1 Started</b>									X			
<b>RLS Tmr 1 Interrupted</b>							X					
<b>RLS Tmr 1 Cancelled</b>								X				
<b>RLS Tmr 2 Started</b>												
<b>RLS Tmr 2 Interrupted</b>												
<b>RLS Tmr 2 Cancelled</b>												

### 11.1.1 Zone Configuration

- Detection Zone -1: Alarm (Hazard Area1, Cross-zoned)
- Detection Zone -2: Alarm (Hazard Area1, Cross-zoned)
- Detection Zone -3: Alarm (Pressure Switch or Water-flow)
- Detection Zone -4: Supervisory (Non-latching by default)

- Detection Zone -5: Abort Switch
- Detection Zone -6: Manual Release Switch
- NAC-1: Signal, will be on steady if there is any alarm zone or manual release switch active
- NAC-2: Signal, indicates the cadence of hazard area 1 state or supervisory circuit (optional)
- RAC-3: Releasing Circuit (Hazard Area 1)
- RAC-4: Releasing Circuit (Hazard Area 1)

### **11.1.2 Hazard Configuration**

- Default Release Timer Value: 60 seconds
- Default Manual Release Delay: 0 seconds
- Default Abort Delay Type: Standard UL
- Default Soak Timer Value: 0 seconds

### **11.1.3 NAC Configuration**

- Default Escalating NAC code of Hazard Area State:
  - Hazard Idle: Off
  - Hazard Alert: Temporal (see Table 9 and Table 10)
  - Hazard Alarm: 120 BPM
  - Hazard Release: Steady
- Default NAC code of Supervisory is 20 BPM.

### **11.1.4 How the Panel Works in Mode 1**

- Activation of either Z-1 or Z-2 turns NAC-1 on steady. Hazard Area 1 state changes from Idle into Alert. NAC-2 turns on at Temporal.
- Activations of both Z-1 and Z-2 change the Hazard Area 1 state from Alert into Alarm. NAC-1 turns on steady. NAC-2 turns on at 120BPM. Release timer-1 (RT-1) is started.
- Expiration of Release Timer-1 change Hazard Area 1 state to Release. Both RAC-3 and RAC-4 turn on. NAC-2 sounds steady.
- Activation of Z-6 in any situation changes Hazard Area 1 state into Alarm. NAC-1 turns on steady, NAC-2 turns on at 120BPM. The manual release delay timer 1 (MDT-1) is started. Upon the expiration of MDT-1, Hazard Area 1 state changes to Release. RAC-3 and RAC-4 are activated. NAC-1 and NAC-2 turn on steady.
- During Hazard Alarm state, after Z-5 (abort switch) is pressed, Release Timer-1 will reset and then restart. NAC-2 rate changes from 120BPM to Temporal. After releasing of Z-5, NAC-2 goes back to 120BPM. Release Timer-1 values depend on Abort Delay Type. If Z-5 is held for any time up to 50 seconds, then the releasing device will actuate 60 seconds after the switch is pressed. However, if Z-5 is held for longer than 50 seconds, then the releasing device will actuate 10 seconds after the switch is released.
- Activation of Z-3 turns both NAC-1 and NAC-2 on steady.
- Activation of Z-4 can be indicated on NAC-2 at 20BPM, if enabled.

## 11.2 Mode 2: Agent Release, Single Hazard, Not Cross-zoned, Combined Release

			Detection Zones						Phantom Zones		Release Timers	
			Z1	Z2	Z3	Z4	Z5	Z6	Zp1	Zp2	RT1 Exp	RT2 Exp
			Alm	Alm	WF	Sup	AB	MR	Z1+Z2	Z3+Z4		
<b>Out1</b>	Signal	Steady	X	X	X			X				
<b>Out2</b>	Signal	Escalating			X	(X)		X				
<b>Out3</b>	Rel.	Releasing						X			X	
<b>Out4</b>	Rel.	Releasing						X			X	
<b>RLS TMR 1 Started</b>			X	X								
<b>RLS Tmr 1 Interrupted</b>							X					
<b>RLS Tmr 1 Cancelled</b>								X				
<b>RLS Tmr 2 Started</b>												
<b>RLS Tmr 2 Interrupted</b>												
<b>RLS Tmr 2 Cancelled</b>												

### 11.2.1 Zone Configuration

- Detection Zone -1: Alarm (Hazard Area 1, not cross-zoned)
- Detection Zone -2: Alarm (Hazard Area 1, not cross-zoned)
- Detection Zone -3: Alarm (Water-flow or pressure switch)
- Detection Zone -4: Supervisory (default non-latching)
- Detection Zone -5: Abort Switch
- Detection Zone -6: Manual Release
- NAC-1: Signal, will be on steady if there is any alarm zone or manual release switch active
- NAC-2: Signal, indicates the cadence of hazard area 1 state or supervisory circuit (optional)
- RAC-3: Releasing Circuit (Hazard Area 1)
- RAC-4: Releasing Circuit (Hazard Area 1)

### 11.2.2 Hazard Configuration

- Default Release Timer Value: 60 seconds
- Default Manual Release Delay: 0 seconds
- Default Abort Delay Type: Standard UL
- Default Soak Timer Value: 0 seconds

### 11.2.3 NAC Configuration

- Default Escalating NAC code of Hazard Area State:
  - Hazard Idle: Off
  - Hazard Alert: Temporal (see Table 9 and Table 10)
  - Hazard Alarm: Temporal
  - Hazard Release: Steady
- Default NAC code of Supervisory Signal is 20 BPM.

#### **11.2.4 How the Panel Works in Mode 2**

- Activation of either Z-1 or Z-2 turns NAC-1 on steady.
- Activation of either Z-1 or Z-2 changes the Hazard Area 1 state from Idle into Alarm directly. NAC-1 turns on steady. NAC-2 turns on Temporal. Release Timer-1 is started.
- Expiration of Release Timer-1 activates both RAC-3 and RAC-4. NAC-1 and NAC-2 turn on steady.
- Activation of Z-6 starts Manual-release Timer 1 (MDT-1) in any situation. NAC-1 turns on steady. NAC-2 turns on Temporal. Upon the expiration of MDT-1, RAC-3 and RAC-4 turn on.
- During Hazard Alarm state, after Z-5 (abort switch) is pressed, Release Timer-1 will reset and then restart. If Z-5 is held for any time up to 50 seconds, then the releasing device will actuate 60 seconds after the switch is pressed. However, if Z-5 is held for longer than 50 seconds, then the releasing device will actuate 10 seconds after the switch is released.
- Activation of Z-3 turns both NAC-1 and NAC-2 on steady.
- Activation of Z-4 can be indicated on NAC-2 at 20BPM, if enabled.

## 11.3 Mode 3: Agent Release, Dual Hazard, Cross-zoned, Split Release



**Attention:** Dual hazard operation is not permissible for UL/ULC operation.

			Detection Zones						Phantom Zones		Release Timers	
			Z1	Z2	Z3	Z4	Z5	Z6	Zp1	Zp2	RT1 Exp	RT2 Exp
			Alm	Alm	Alm	Alm	AB/MR	AB/MR	Z1+Z2	Z3+Z4		
<b>Out1</b>	Signal	Steady					X		X			
<b>Out2</b>	Signal	Escalating						X		X		
<b>Out3</b>	Rel.	Releasing				X				X		
<b>Out4</b>	Rel.	Releasing						X			X	
<b>RLS TMR 1 Started</b>									X			
<b>RLS Tmr 1 Interrupted</b>						X						
<b>RLS Tmr 1 Cancelled</b>						X						
<b>RLS Tmr 2 Started</b>										X		
<b>RLS Tmr 2 Interrupted</b>								X				
<b>RLS Tmr 2 Cancelled</b>								X				

### 11.3.1 Zone Configuration

- Detection Zone -1: Alarm (Hazard Area 1, Cross-zoned)
- Detection Zone -2: Alarm (Hazard Area 1, Cross-zoned)
- Detection Zone -3: Alarm (Hazard Area 2, Cross-zoned)
- Detection Zone -4: Alarm (Hazard Area 2, Cross-zoned)
- Detection Zone -5: Abort/Manual Release Combination (Hazard Area 1)
- Detection Zone -6: Abort/Manual Release Combination (Hazard Area 2)
- NAC -1: Escalating Signal, indicates Hazard Area 1 state
- NAC -2: Escalating Signal, indicates Hazard Area 2 state
- RAC -3: Releasing Circuit (Hazard Area 1)
- RAC -4: Releasing Circuit (Hazard Area 2)

### 11.3.2 Hazard Configuration

- Default Release Timer Value: 60 seconds
- Default Manual Release Delay: 0 seconds
- Default Abort Delay Type: Standard UL
- Default Soak Timer Value: 0 seconds

### 11.3.3 NAC Configuration

- Default Escalating NAC code of Hazard Area State:
  - Hazard Idle: Off
  - Hazard Alert: Temporal (see Table 9 and Table 10)
  - Hazard Alarm: 120 BPM
  - Hazard Release: Steady

### 11.3.4 How the Panel Works in Mode 3

- Activation of either Z-1 or Z-2 changes Hazard Area1 state from Idle into Alert. NAC-1 turns on at Temporal.
- Activations of both Z-1 and Z-2 change Hazard Area1 state from Alert into Alarm. NAC-1 turns on at 120BPM. Release Timer-1 is started.
- Upon the expiration of Release Timer-1, RAC-3 is activated. NAC-1 turns on steady.
- Short on Z-5 indicates Manual Release Switch active. Manual Release Delay Timer 1 (MDT-1) is started. NAC-1 turns on at 120 BPM while this timer is running. Upon the expiration of MDT-1, NAC-1 turns on steady and RAC-3 is activated.
- A current limit on Z-5 means Abort Switch active. Hazard Area 1 state changes from Alarm to Alert. Release Timer is held and NAC-1 changes from 120BPM to Temporal.
- Removal of the current limit on Z-5 means that Abort Switch is released. Hazard Area 1 state changes from Alert to Alarm. Release Timer -1 resumes running and NAC-1 goes back to 120BPM. Release Timer-1 value depends on Abort Delay Type.
- Activation of either Z-3 or Z-4 changes Hazard Area 2 state from Idle into Alert. NAC-2 turns on at Temporal.
- Activations of both Z-3 and Z-4 turn the Hazard Area 2 state from Alert into Alarm. NAC-2 turns on at 120BPM. Release timer-2 is started.
- Upon the expiration of Release Timer-2, RAC-4 is activated. NAC-2 turns on steady.
- Short on Z-6 indicates Manual Release Switch active. Manual Release Delay Timer - 2 (MDT-2) is started. NAC-2 turns on at 120 BPM while this timer is running. Upon the expiration of MDT-2, NAC-2 turns on steady and RAC-4 is activated.
- A current limit on Z-6 means Abort Switch active. Hazard Area 1 state changes from Alarm to Alert. Release Timer -2 is held and NAC-2 changes from 120BPM to Temporal.
- Removal of the current limit on Z-6 means Abort Switch is released. Hazard Area 1 state changes from Alert to Alarm. Release Timer -2 resumes running and NAC-2 goes back to 120BPM. Release Timer-2 value depends on Abort Delay Type.

## 11.4 Mode 4: Agent Release, Dual Hazard, Not Cross-zoned, Split Release



**Attention:** Dual hazard operation is not permissible for UL/ULC operation.

			Detection Zones						Phantom Zones		Release Timers	
			Z1	Z2	Z3	Z4	Z5	Z6	Zp1	Zp2	RT1 Exp	RT2 Exp
			Alm	Alm	Alm	Alm	AB/MR	AB/MR	Z1+Z2	Z3+Z4		
<b>Out1</b>	Signal	Steady	X	X			X					
<b>Out2</b>	Signal	Escalating			X	X		X				
<b>Out3</b>	Rel.	Releasing					X			X		
<b>Out4</b>	Rel.	Releasing						X			X	
<b>RLS TMR 1 Started</b>			X	X								
<b>RLS Tmr 1 Interrupted</b>							X					
<b>RLS Tmr 1 Cancelled</b>							X					
<b>RLS Tmr 2 Started</b>					X	X						
<b>RLS Tmr 2 Interrupted</b>								X				
<b>RLS Tmr 2 Cancelled</b>								X				

### 11.4.1 Zone Configuration

- Detection Zone -1: Alarm (Hazard Area 1, not cross-zoned)
- Detection Zone -2: Alarm (Hazard Area 1, not cross-zoned)
- Detection Zone -3: Alarm (Hazard Area 2, not cross-zoned)
- Detection Zone -4: Alarm (Hazard Area 2, not cross-zoned)
- Detection Zone -5: Abort/Manual Release Combination (hazard 1)
- Detection Zone -6: Abort/Manual Release Combination (hazard 2)
- NAC -1: Escalating Signal, indicates Hazard Area 1 state
- NAC -2: Escalating Signal, indicates Hazard Area 2 state
- RAC -3: Releasing Circuit (Hazard Area 1)
- RAC -4: Releasing Circuit (Hazard Area 2)

### 11.4.2 Hazard Configuration

- Default Release Timer Value: 60 seconds
- Default Manual Release Delay: 0 seconds
- Default Abort Delay Type: Standard UL
- Default Soak Timer Value: 0 seconds

### 11.4.3 NAC Configuration

- Default Escalating NAC code of Hazard Area State:
  - Hazard Idle: Off
  - Hazard Alarm: Temporal (see Table 9 and Table 10)
  - Hazard Release: Steady

#### 11.4.4 How the Panel Works in Mode 4

- Activation of either Z-1 or Z-2 changes Hazard Area1 state from Idle to Alarm. NAC-1 turns on at Temporal. Release Timer-1 is started.
- Upon expiration of Release Timer-1, RAC-3 is activated. NAC-1 turns on Steady.
- A current limit on Z-5 means Abort Switch active. Release Timer-1 is held. NAC-1 turns on at Temporal. Removal of the current limit on Z-5 means that Abort Switch is released. Release Timer -1 resumes. Release Timer value depends on Abort Delay Type.
- Short on Z-5 indicates Manual Release active. Manual Release Delay Timer - 1 (MDT-1) is started. NAC-1 turns on at Temporal. Upon the expiration of MDT-1, NAC-1 turns on steady and RAC-3 is activated.
- Activation of either Z-3 or Z-4 turns the Hazard Area 2 state from Idle into Alarm. NAC-2 turns on at Temporal. Release timer-2 is started.
- Upon expiration of Release Timer-2, RAC-4 is activated. NAC-2 turns on steady.
- A current limit on Z-6 means Abort Switch active. Release Timer -2 is held. Removal of the current limit on Z-6, means releasing Abort Switch. Release Timer -2 resumes running. Release Timer 2 value depends on Abort Delay Type.
- Short on Z-6 indicates Manual Release active and Manual Release Delay Timer - 2(MDT-2) is started. NAC-2 turns on at Temporal. Upon the expiration of MDT-2, NAC-2 turns on steady and RAC-4 is activated.

## 11.5 Mode 5: Pre-action/Deluge, Single Hazard, Cross-zoned, Combined Release

			Detection Zones						Phantom Zone	Release Timer
			Z1	Z2	Z3	Z4	Z5	Z6	Zp1	RT1 Exp
			Alm	Alm	Alm	Alm	Supv	WF	Z1+Z2+Z3+Z4	
<b>Out1</b>	Signal	Steady	X	X	X	X		X		
<b>Out2</b>	Signal	Escalating					(X)	X		
<b>Out3</b>	Rel.	Releasing							X	
<b>Out4</b>	Rel.	Releasing							X	
<b>RLS TMR 1 Started</b>								X		
<b>RLS Tmr 1 Interrupted</b>										
<b>RLS Tmr 1 Cancelled</b>										

### 11.5.1 Zone Configuration

- Detection Zone -1: Alarm (Hazard Area 1, cross-zoned)
- Detection Zone -2: Alarm (Hazard Area 1, cross-zoned)
- Detection Zone -3: Alarm (Hazard Area 1, cross-zoned)
- Detection Zone -4: Alarm (Hazard Area 1, cross-zoned)
- Detection Zone -5: Supervisory
- Detection Zone -6: Water-flow Alarm
- NAC -1: Signal, will be activated if there is any alarm zone active
- NAC -2: Escalating Signal, indicates Hazard Area 1 status, Supervisory Optional
- RAC -3: Releasing Circuit (Hazard Area 1)
- RAC -4: Releasing Circuit (Hazard Area 1)

### 11.5.2 Hazard Configuration

- Default Release Timer Value: 0 seconds
- Default Manual Release Delay: 0 seconds (not used)
- Default Abort Delay Type: Standard UL (not used)
- Default Soak Timer Value: 0 seconds (continuous)

### 11.5.3 NAC Configuration

- Default Escalating NAC code of Hazard Area State:
  - Hazard Idle: Off
  - Hazard Alert: Temporal (see Table 9 and Table 10)
  - Hazard Alarm: 120 BPM
  - Hazard Release: Steady
- Default NAC code of Supervisory is 20 BPM.

### 11.5.4 How the Panel Works in Mode 5

- Activation of Z-1, Z-2, Z-3 or Z-4 changes Hazard Area 1 state from Idle to Alert. NAC-1 turns on steady. NAC-2 sounds Temporal.
- Activations of any two of Z-1, Z-2, Z-3 and Z-4 change Hazard Area 1 state into Alarm. Release Timer-1 is started. NAC-2 turns on at 120 BPM. Upon the expiration of Release Timer 1, both RAC-3 and RAC-4 turn on. NAC-1 and NAC-2 turn on Steady
- Activation of Z-6 turns on both NAC-1 and NAC-2 steady.
- Activation of Z-5 is indicated on NAC-2 at 20 BPM, if configured.

## 11.6 Mode 6: Pre-action/Deluge, Single Hazard, Not Cross-zoned, Combined Release

			Detection Zones						Phantom Zone	Release Timer
			Z1	Z2	Z3	Z4	Z5	Z6	Zp1	RT1 Exp
			Alm	Alm	Alm	Alm	Supv	WF	Z1+Z2+Z3+Z4	
<b>Out1</b>	Signal	Steady	X	X	X	X		X		
<b>Out2</b>	Signal	Escalating					(X)			
<b>Out3</b>	Rel.	Releasing							X	
<b>Out4</b>	Rel.	Releasing							X	
<b>RLS TMR 1 Started</b>			X	X	X	X				
<b>RLS Tmr 1 Interrupted</b>										
<b>RLS Tmr 1 Cancelled</b>										

### 11.6.1 Zone Configuration

- Detection Zone -1: Alarm (Hazard Area 1, not cross-zoned)
- Detection Zone -2: Alarm (Hazard Area 1, not cross-zoned)
- Detection Zone -3: Alarm (Hazard Area 1, not cross-zoned)
- Detection Zone -4: Alarm (Hazard Area 1, not cross-zoned)
- Detection Zone -5: Supervisory
- Detection Zone -6: Water-flow
- NAC -1: Signal, steady on any alarm
- NAC -2: Supervisory optional
- RAC -3: Releasing Circuit (Hazard Area 1)
- RAC -4: Releasing Circuit (Hazard Area 1)

### 11.6.2 Hazard Configuration

- Default Release Timer Value: 0 seconds
- Default Manual Release Delay: 0 seconds (not used)
- Default Abort Delay Type: Standard UL (not used)
- Default Soak Timer Value: 0 seconds (continuous)

### 11.6.3 NAC Configuration

- Default Escalating NAC code of Hazard Area State:
  - Hazard Idle: Off
  - Hazard Alert: Temporal (see Table 9 and Table 10)
  - Hazard Alarm: Temporal (see Table 9 and Table 10)
  - Hazard Release: Steady
- Default NAC code of Supervisory is 20 BPM.

### 11.6.4 How the Panel Works in Mode 6

- Activation of any one among Z-1, Z-2, Z-3 and Z-4 changes Hazard Area 1 state into Alarm. Release Timer-1 is started. NAC-1 turns on at Temporal. Upon the expiration of Release Timer-1, NAC-1 turns on steady. RAC-3 and RAC-4 are activated.
- Activation of Z-5 can be indicated on NAC-2 at 20 BPM, if configured.
- Activation of Z-6 turns NAC-1 steady.

## 11.7 Mode 7: Pre-action/Deluge, Dual Hazard, Cross-zoned, Split Release

			Detection Zones				Phantom Zones		Release Timers			
			Z1	Z2	Z3	Z4	Z5	Z6	Zp1	Zp2	RT1 Exp	RT2 Exp
			Alm	Alm	Alm	Alm	Supv	WF	Z1+Z2	Z3+Z4		
<b>Out1</b>	Signal	Steady						X	X			
<b>Out2</b>	Signal	Escalating						X		X		
<b>Out3</b>	Rel.	Releasing									X	
<b>Out4</b>	Rel.	Releasing										X
<b>RLS TMR 1 Started</b>									X			
<b>RLS Tmr 1 Interrupted</b>												
<b>RLS Tmr 1 Cancelled</b>												
<b>RLS Tmr 2 Started</b>										X		
<b>RLS Tmr 2 Interrupted</b>												
<b>RLS Tmr 2 Cancelled</b>												

### 11.7.1 Zone Configuration

- Detection Zone -1: Alarm (Hazard Area 1, cross-zoned)
- Detection Zone -2: Alarm (Hazard Area 1, cross-zoned)
- Detection Zone -3: Alarm (Hazard Area 2, cross-zoned)
- Detection Zone -4: Alarm (Hazard Area 2, cross-zoned)
- Detection Zone -5: Supervisory
- Detection Zone -6: Water-flow
- NAC -1: Escalating Signal, indicates Hazard Area 1 status
- NAC -2: Escalating Signal, indicates Hazard Area 2 status
- RAC -3: Releasing Circuit (Hazard Area 1)
- RAC -4: Releasing Circuit (Hazard Area 2)

### 11.7.2 Hazard Configuration

- Default Release Timer Value: 0 seconds
- Default Manual Release Delay: 0 seconds (not used)
- Default Abort Delay Type: Standard UL (not used)
- Default Soak Timer Value: 0 seconds (continuous)

### 11.7.3 NAC Configuration

- Default Escalating NAC code of Hazard Area State:
  - Hazard Idle: Off
  - Hazard Alert: Temporal (see Table 9 and Table 10)
  - Hazard Alarm: 120BPM
  - Hazard Release: Steady
- Default NAC code of Supervisory is 20 BPM.

#### **11.7.4 How the Panel Works in Mode 7**

- Activation of either Z-1 or Z-2 changes Hazard Area 1 state into Alert. NAC-1 turns on at Temporal.
- Activations of both Z-1 and Z-2 change Hazard Area 1 state into Alarm. Release Timer-1 is started. Upon the expiration of Release Timer-1, RAC-3 is active. NAC-1 turns on steady.
- Activation of either Z-3 or Z-4 changes Hazard Area 2 state into Alert. NAC-2 turns on at Temporal.
- Activations of both Z-3 and Z-4 changes Hazard Area 2 state into Alarm. Release Timer 2 is started. Upon the expiration of Release Timer 2, RAC-4 is active. NAC-2 turns on steady.
- Activation of Z-6 turns both NAC-1 and NAC-2 steady.
- Activation of Z-5 can be indicated on NAC-2, if enabled.

## 11.8 Mode 8: Pre-action/Deluge, Dual Hazard, Not Cross-zoned, Split Release

			Detection Zones				Phantom Zones		Release Timers			
			Z1	Z2	Z3	Z4	Z5	Z6	Zp1	Zp2	RT1 Exp	RT2 Exp
			Alm	Alm	Alm	Alm	Supv	WF	Z1+Z2	Z3+Z4		
<b>Out1</b>	Signal	Steady	X	X				X				
<b>Out2</b>	Signal	Escalating			X	X		X				
<b>Out3</b>	Rel.	Releasing									X	
<b>Out4</b>	Rel.	Releasing										X
<b>RLS TMR 1 Started</b>			X	X								
<b>RLS Tmr 1 Interrupted</b>												
<b>RLS Tmr 1 Cancelled</b>												
<b>RLS Tmr 2 Started</b>					X	X						
<b>RLS Tmr 2 Interrupted</b>												
<b>RLS Tmr 2 Cancelled</b>												

### 11.8.1 Zone Configuration

- Detection Zone -1: Alarm (Hazard Area 1, not cross-zoned)
- Detection Zone -2: Alarm (Hazard Area 1, not cross-zoned)
- Detection Zone -3: Alarm (Hazard Area 2, not cross-zoned)
- Detection Zone -4: Alarm (Hazard Area 2, not cross-zoned)
- Detection Zone -5: Supervisory
- Detection Zone -6: Water-flow
- NAC -1: Escalating Signal, indicates Hazard Area 1 status
- NAC -2: Escalating Signal, indicates Hazard Area 2 status
- RAC -3: Releasing Circuit (Hazard Area 1)
- RAC -4: Releasing Circuit (Hazard Area 2)

### 11.8.2 Hazard Configuration

- Default Release Timer Value: 0 seconds
- Default Manual Release Delay: 0 seconds (not used)
- Default Abort Delay Type: Standard UL (not used)
- Default Soak Timer Value: 0 seconds (continuous)

### 11.8.3 NAC Configuration

- Default Escalating NAC code of Hazard Area State:
  - Hazard Idle: Off
  - Hazard Alert: Temporal (see Table 9 and Table 10)
  - Hazard Alarm: Temporal (see Table 9 and Table 10)
  - Hazard Release: Steady
- Default NAC code of Supervisory is 20 BPM.

#### **11.8.4 How the Panel Works in Mode 8**

- Activation of either Z-1 or Z-2 changes Hazard Area 1 state into Alarm. Release Timer 1 is started. NAC-1 turns on at Temporal. Upon the expiration of Release Timer 1, RAC-3 is active. NAC-1 turns on steady.
- Activation of either Z-3 or Z-4 changes Hazard Area 2 state into Alarm. Release Timer 2 is started. NAC-2 turns on at Temporal. Upon expiration of Release Timer 2, RAC-4 is active. NAC-2 turns on steady.
- Activation of Z-6 turns both NAC-1 and NAC-2 on steady.
- Activation of Z-5 can be indicated on NAC-2, if enabled.

## 11.9 Mode 9: Agent Release, Single Hazard, Cross-zoned, NYC abort

			Detection Zones						Phantom Zones		Release Timers	
			Z1	Z2	Z3	Z4	Z5	Z6	Zp1	Zp2	RT1 Exp	RT2 Exp
			Alm	Alm	WF	Supv	AB	MR	Z1+Z2	Z3+Z4		
<b>Out1</b>	Signal	Steady							X			
<b>Out2</b>	Signal	Escalating			X	(X)		X	X			
<b>Out3</b>	Rel.	Releasing						X			X	
<b>Out4</b>	Strobe	Steady			X			X	X		X	
<b>RLS TMR 1 Started</b>									X			
<b>RLS Tmr 1 Interrupted</b>							X					
<b>RLS Tmr 1 Cancelled</b>								X				
<b>RLS Tmr 2 Started</b>												
<b>RLS Tmr 2 Interrupted</b>												
<b>RLS Tmr 2 Cancelled</b>												

### 11.9.1 Zone Configuration

- Detection Zone -1: Alarm (Hazard Area 1, cross-zoned)
- Detection Zone -2: Alarm (Hazard Area 1, cross-zoned)
- Detection Zone -3: Alarm (Pressure Switch or Water-flow)
- Detection Zone -4: Supervisory
- Detection Zone -5: Abort Switch
- Detection Zone -6: Manual Release
- NAC-1: Escalating Signal, indicate Hazard Area 1 status
- NAC-2: Escalating Signal, indicate Hazard Area 1 status, Supervisory Optional
- RAC-3: Releasing Circuit (Hazard Area 1)
- NAC-4: Silenceable Strobe

### 11.9.2 Hazard Configuration

- Default Release Timer Value: 60 seconds
- Default Manual Release Delay: 0 seconds
- Default Abort Delay Type: NYC
- Default Soak Timer Value: 0 seconds (continuous)

### 11.9.3 NAC Configuration

- Default Escalating NAC code of Hazard Area State:
  - Hazard Idle: Off
  - Hazard Alert: Steady
  - Hazard Alarm: 120BPM
  - Hazard Release: Steady
- Default NAC code of supervisory is 20 BPM

#### 11.9.4 How the Panel Works in Mode 9

- The activation of either Z-1 or Z-2 turns NAC-1 on steady.
- The activations of both Z-1 and Z-2 turn NAC-1 off, turn NAC-2 on at 120BPM, and turn NAC-4 on steady. Hazard Area 1 state changes to Alarm. Release Timer-1 is started. Upon the expiration of Release Timer 1, RAC-3 is active, NAC-1 and NAC-2 turn on steady, and NAC-4 remains on steady.
- If Abort Switch Z-5 is active when Release Timer-1 is running, Hazard Area 1 state changes to Alert. NAC-2 turns off and NAC-1 turns on Steady. Release Timer-1 is held.
- If Abort Switch Z-5 is released, NAC-1 turns off and NAC-2 turns on 120BPM. Release Timer resumes running. Release Timer-1's value depends on Abort Delay Type.
- Activation of Z-6 starts Manual Release Timer 1 (MDT-1). Upon the expiration of MDT-1, NAC-2 and NAC-4 turn on steady. RAC-3 is active.
- Activation of Z-4 is indicated at 20BPM on NAC-2, if configured.



**Note:** NAC-4 is to be used only for unsynchronized strobes, such as a strobe installed over a doorway to indicate that a hazard zone is in the alarm state.

## 11.10 Mode 10: Agent Release, Single Hazard, Not Cross-zoned, Combined Release

			Detection Zones						Phantom Zones		Release Timers	
			Z1	Z2	Z3	Z4	Z5	Z6	Zp1	Zp2	RT1 Exp	RT2 Exp
			Alm	Alm	WF	Supv	AB	MR	Z1+Z2	Z3+Z4		
<b>Out1</b>	Signal	Steady	X	X	X			X				
<b>Out2</b>	Signal	Escalating			X	(X)		X	X			
<b>Out3</b>	Rel.	Releasing						X			X	
<b>Out4</b>	Rel.	Releasing						X			X	
<b>RLS TMR 1 Started</b>									X			
<b>RLS Tmr 1 Interrupted</b>							X					
<b>RLS Tmr 1 Cancelled</b>								X				
<b>RLS Tmr 2 Started</b>												
<b>RLS Tmr 2 Interrupted</b>												
<b>RLS Tmr 2 Cancelled</b>												

### 11.10.1 Zone Configuration

- Detection Zone -1: Alarm (Hazard Area1, not cross-zoned)
- Detection Zone -2: Alarm (Hazard Area1, not cross-zoned)
- Detection Zone -3: Alarm (Pressure Switch or Water-flow)
- Detection Zone -4: Supervisory
- Detection Zone -5: Abort Switch
- Detection Zone -6: Manual Release
- NAC -1: Signal, will be activated steady when there is any alarm zone active
- NAC -2: Signal, indicate the Hazard Area1 status
- RAC -3: Releasing Circuit
- RAC -4: Releasing Circuit

### 11.10.2 Hazard Configuration

- Default Release Timer Value: 60 seconds
- Default Manual Release Delay: 0 seconds
- Default Abort Delay Type: Standard UL
- Soak Timer Value: 0 seconds (continuous)

### 11.10.3 NAC Configuration

- Default Escalating NAC code of Hazard Area State:
  - Hazard Idle: Off
  - Hazard Alert: 20BPM
  - Hazard Alarm: 60BPM
  - Hazard Release: Steady
- Default NAC code of supervisory is Temporal (see Table 9 and Table 10)

#### **11.10.4 How the Panel Works in Mode 10**

- Activation of either Z-1 or Z-2 turns NAC-1 on steady.
- Activation of either Z-1 or Z-2 turns NAC-2 on at 60BPM. Release Timer-1 is started.
- Expiration of Release Timer-1 activates both RAC-3 and RAC-4. NAC-1 and NAC-2 turn on steady.
- Activation of Z-6 starts Manual Release Delay Timer -1(MDT-1). Upon the expiration of MDT-1, both RAC-3 and RAC-4 are active. NAC-1 and NAC-2 turn on steady.
- If Z-5 is active, NAC-2 is downgraded from 60BPM to 20BPM. After releasing of Z-5, NAC-2 goes back to 60BPM. Release Timer-1's values depend on Abort Delay Type.
- During Hazard Alarm state, after Z-5 (abort switch) is pressed, Release Timer-1 will reset and then restart. If Z-5 is held for any time up to 50 seconds, then the releasing device will actuate 60 seconds after the switch is pressed. However, if Z-5 is held for longer than 50 seconds, then the releasing device will actuate 10 seconds after the switch is released.
- Activation of Z-3 turns both NAC-1 and NAC-2 on steady.
- Activation of Z-4 can be indicated on NAC-2 at Temporal, if configured.

## 11.11 Mode 11: Agent Release, Single Hazard, Cross-zoned, Combined Release

			Detection Zones						Phantom Zones		Release Timers	
			Z1	Z2	Z3	Z4	Z5	Z6	Zp1	Zp2	RT1 Exp	RT2 Exp
			Alm	Alm	WF	Supv	AB	MR	Z1+Z2	Z3+Z4		
<b>Out1</b>	Signal	Steady							X			
<b>Out2</b>	Signal	Escalating			X	(X)		X	X			
<b>Out3</b>	Rel.	Releasing						X			X	
<b>Out4</b>	Rel.	Releasing						X			X	
<b>RLS TMR 1 Started</b>									X			
<b>RLS Tmr 1 Interrupted</b>							X					
<b>RLS Tmr 1 Cancelled</b>								X				
<b>RLS Tmr 2 Started</b>												
<b>RLS Tmr 2 Interrupted</b>												
<b>RLS Tmr 2 Cancelled</b>												

### 11.11.1 Zone Configuration

- Detection Zone -1: Alarm (Hazard Area1, cross-zoned)
- Detection Zone -2: Alarm (Hazard Area1, cross-zoned)
- Detection Zone -3: Alarm (Pressure Switch or Water-flow)
- Detection Zone -4: Supervisory (Default non-latching)
- Detection Zone -5: Abort Switch
- Detection Zone -6: Manual Release
- NAC -1: Signal, indicate the Hazard Area1 status
- NAC -2: Signal, indicate the Hazard Area1 status
- RAC -3: Releasing Circuit
- RAC -4: Releasing Circuit

### 11.11.2 Hazard Configuration

- Default Release Timer Value: 60 seconds
- Default Manual Release Delay: 0 seconds
- Default Abort Delay Type: Standard UL
- Soak Timer Value: 0 seconds (continuous)

### 11.11.3 NAC Configuration

- Default Escalating NAC code of Hazard Area State:
  - Hazard Idle: Off
  - Hazard Alert: Steady
  - Hazard Alarm: 60BPM
  - Hazard Release: Steady
- Default NAC code of supervisory is 20 BPM

#### 11.11.4 How the Panel Works in Mode 11

- The activation of either Z-1 or Z-2 turns NAC-1 on at Temporal.
- The activations of both Z-1 and Z-2 turn NAC-1 off and turn NAC-2 on at 60BPM. Release Timer-1 is started.
- Expiration of Release Timer-1 results in the activation of RAC-3 and RAC-4. NAC-2 turns on steady.
- If Z-5 is active, NAC-2 turns off and NAC-1 turns on instead. After releasing of Z-5, NAC-1 turns off and NAC-2 turns on at 60BPM. Release Timer-1's values depend on Abort Delay Type.
- During Hazard Alarm state, after Z-5 (abort switch) is pressed, Release Timer-1 will reset and then restart. If Z-5 is held for any time up to 50 seconds, then the releasing device will actuate 60 seconds after the switch is pressed. However, if Z-5 is held for longer than 50 seconds, then the releasing device will actuate 10 seconds after the switch is released.
- Activation of Z-6 starts Manual Release Delay Timer-1(MDT-1). Upon the expiration of MDT-1, RAC-3 and RAC-4 are active. NAC-2 turns on steady.
- Activation of Z-3 turns NAC-2 on steady.
- Activation of Z-4 can be indicated on NAC-2 at 20BPM, if configured.

## 11.12 Mode 12: Pre-action/Deluge, Single Hazard, Cross-zoned, Combined Release



**Attention: This mode of operation is not FM approved.**

			Detection Zones						Phantom Zone	Release Timer
			Z1	Z2	Z3	Z4	Z5	Z6	Zp1	RT1 Exp
			Alm	Alm	Alm	Supv	Supv	WF	Z1+Z2+Z3	
<b>Out1</b>	Signal	Steady	X	X	X			X		
<b>Out2</b>	Signal	Escalating				(X)	(X)	X		
<b>Out3</b>	Rel.	Releasing							X	
<b>Out4</b>	Rel.	Releasing							X	
<b>RLS TMR 1 Started</b>								X		
<b>RLS Tmr 1 Interrupted</b>										
<b>RLS Tmr 1 Cancelled</b>										

### 11.12.1 Zone Configuration

- Detection Zone -1: Alarm (Hazard Area 1, cross-zoned)
- Detection Zone -2: Alarm (Hazard Area 1, cross-zoned)
- Detection Zone -3: Alarm (Hazard Area 1, cross-zoned)
- Detection Zone -4: Supervisory
- Detection Zone -5: Supervisory
- Detection Zone -6: Water-flow Alarm
- NAC -1: Signal, will be activated if there is any alarm zone active
- NAC -2: Escalating Signal, indicates Hazard Area 1 status, Supervisory Optional
- RAC -3: Releasing Circuit (Hazard Area 1)
- RAC -4: Releasing Circuit (Hazard Area 1)

### 11.12.2 Hazard Configuration

- Default Release Timer Value: 0 seconds
- Default Manual Release Delay: 0 seconds (not used)
- Default Abort Delay Type: Standard UL (not used)
- Default Soak Timer Value: 0 seconds (continuous)

### 11.12.3 NAC Configuration

- Default Escalating NAC code of Hazard Area State:
- Hazard Idle: Off
- Hazard Alert: Temporal (see Table 9 and Table 10)
- Hazard Alarm: 120 BPM
- Hazard Release: Steady
- Default NAC code of Supervisory is 20 BPM.

#### **11.12.4 How the Panel Works in Mode 12**

- Activation of Z-1, Z-2 or Z-3 changes Hazard Area 1 state from Idle to Alert. NAC-1 turns on steady. NAC-2 sounds Temporal.
- Activations of any two of Z-1, Z-2 and Z-3 change Hazard Area 1 state into Alarm. Release Timer-1 is started. NAC-2 turns on at 120 BPM. Upon the expiration of Release Timer 1, both RAC-3 and RAC-4 turn on Steady. RAC-3 and RAC-4 are activated.
- Activation of Z-6 turns on both NAC-1 and NAC-2 steady.
- Activation of Z-4 or Z-5 is indicated on NAC-2 at 20 BPM, if configured.

## 11.13 Mode 13: Pre-action/Deluge, Single Hazard, Not Cross-zoned, Combined Release

			Detection Zones						Phantom Zone	Release Timer
			Z1	Z2	Z3	Z4	Z5	Z6	Zp1	RT1 Exp
			Alm	Alm	Alm	Supv	Supv	WF	Z1+Z2+Z3	
<b>Out1</b>	Signal	Steady	X	X	X			X		
<b>Out2</b>	Signal	Escalating				(X)	(X)	X		
<b>Out3</b>	Rel.	Releasing							X	
<b>Out4</b>	Rel.	Releasing							X	
<b>RLS TMR 1 Started</b>			X	X	X					
<b>RLS Tmr 1 Interrupted</b>										
<b>RLS Tmr 1 Cancelled</b>										

### 11.13.1 Zone Configuration

- Detection Zone -1: Alarm (Hazard Area 1, not cross-zoned)
- Detection Zone -2: Alarm (Hazard Area 1, not cross-zoned)
- Detection Zone -3: Alarm (Hazard Area 1, not cross-zoned)
- Detection Zone -4: Supervisory
- Detection Zone -5: Supervisory
- Detection Zone -6: Water-flow
- NAC -1: Signal, steady on any alarm
- NAC -2: Escalating signal, indicates Hazard Area 1 status, Supervisory Optional
- RAC -3: Releasing Circuit (Hazard Area 1)
- RAC -4: Releasing Circuit (Hazard Area 1)

### 11.13.2 Hazard Configuration

- Default Release Timer Value: 0 seconds
- Default Manual Release Delay: 0 seconds (not used)
- Default Abort Delay Type: Standard UL (not used)
- Default Soak Timer Value: 0 seconds (continuous)

### 11.13.3 NAC Configuration

- Default Escalating NAC code of Hazard Area State:
- Hazard Idle: Off
- Hazard Alert: Temporal (see Table 9 and Table 10)
- Hazard Alarm: Temporal (see Table 9 and Table 10)
- Hazard Release: Steady
- Default NAC code of Supervisory is 20 BPM.

### 11.13.4 How the Panel Works in Mode 13

- Activation of any one among Z-1, Z-2 or Z-3 changes Hazard Area 1 state into Alarm. Release Timer-1 is started. NAC-1 turns on at Temporal. Upon the expiration of Release Timer-1, NAC-1 turns on steady. RAC-3 and RAC-4 are activated.
- Activation of Z4 or Z-5 can be indicated on NAC-2 at 20 BPM, if configured.
- Activation of Z-6 turns NAC-1 and NAC-2 steady.

## 11.14 Mode 14: Pre-action/Deluge, Single Hazard, Not Cross-zoned, Combined Release



**Attention:** This mode of operation is neither FM nor UL approved.

			Detection Zones						Phantom Zone	Release Timer
			Z1	Z2	Z3	Z4	Z5	Z6	Zp1	RT1 Exp
			Alm	Alm	Alm	Alm	Supv	WF	Z1+Z2+Z3	
<b>Out1</b>	Signal	Steady	X	X	X	X		X		
<b>Out2</b>	Signal	Escalating					(X)	X		
<b>Out3</b>	Rel.	Releasing							X	
<b>Out4</b>	Rel.	Releasing							X	
<b>RLS TMR 1 Started</b>			X	X	X	X				
<b>RLS Tmr 1 Interrupted</b>										
<b>RLS Tmr 1 Cancelled</b>										

### 11.14.1 Zone Configuration

- Detection Zone -1: Alarm (Hazard Area 1, not cross-zoned)
- Detection Zone -2: Alarm (Hazard Area 1, not cross-zoned)
- Detection Zone -3: Alarm (Hazard Area 1, not cross-zoned)
- Detection Zone -4: Alarm (Hazard Area 1, not cross-zoned)
- Detection Zone -5: Supervisory
- Detection Zone -6: Water-flow
- NAC -1: Signal, steady on any alarm
- NAC -2: Escalating Signal, indicates Hazard Area 1 status, Supervisory Optional
- RAC -3: Releasing Circuit (Hazard Area 1)
- RAC -4: Releasing Circuit (Hazard Area 1)

### 11.14.2 Hazard Configuration

- Default Release Timer Value: 0 seconds
- Default Manual Release Delay: 0 seconds (not used)
- Default Abort Delay Type: Standard UL (not used)
- Default Soak Timer Value: 0 seconds (continuous)

### 11.14.3 NAC Configuration

- Default Escalating NAC code of Hazard Area State:
- Hazard Idle: Off
- Hazard Alert: Temporal (see Table 9 and Table 10)
- Hazard Alarm: Temporal (see Table 9 and Table 10)
- Hazard Release: Steady
- Default NAC code of Supervisory is 20 BPM.

#### 11.14.4 How the Panel Works in Mode 14

- Activation of any one among Z-1, Z-2, Z-3 or Z4 changes Hazard Area 1 state into Alarm. Release Timer-1 is started. NAC-1 turns on steady. NAC-2 turns on Temporal if the release timer is non-zero. Upon the expiration of Release Timer-1, both NAC-1 and NAC-2 turn on steady. RAC-3 and RAC-4 are activated.
- Activation of Z-5 can be indicated on NAC-2 at 20 BPM, if configured.
- Activation of Z-6 turns NAC-1 and NAC-2 steady.



- For the use of the system for pre-action, deluge releasing applications.
- Acceptable, Approved solenoids for the FR-320 Series are listed in Appendix A.
- Secondary power supply must provide for minimum of 90 hours of standby operation followed by 10 minutes of releasing and alarm operation. See Appendix D.
- Minimum secondary supply voltage for this application is 21.1 VDC. In order to maintain required operating voltage at the solenoid, wiring lengths must not be as such as to exceed the maximum line resistance value of 1 Ohms at a maximum load of 1A.
- Initiating device circuits must be class A for this application, thus necessitating use of the ICAC-306 Class A Converter Module.

# Appendix A: Compatible Solenoids

Manufacturer	Description
<b>Safety Hi-Tech</b>	
SH21006403 (S3023024SHT)	Valve solenoid
SH21006404 (S3023024SHT)	Valve solenoid
<b>ASCO 8210 series</b>	
T8210A107 24VDC	
R8210A107 24VDC	
8210A107 24VDC	
<b>AMEREX</b>	
17014	Actuator
<b>BSCO</b>	
510006	Actuator
<b>Kidde Fenwal Protection Systems</b>	
486500-01	Actuator
<b>Parker</b>	
73212	Valve Solenoid
<b>Parker Skinner Valve Division Cardox 7-061-0006</b>	
V5L 72750	Valve Solenoid
<b>SIEMENS</b>	
CPYEC-2-24	Supervised Solenoid
CPYEC-24	Supervised Solenoid
<b>TSP</b>	
17842	Actuator

# Appendix B: Compatible Synchronized Modules and Horn/Strobes (UL/ULC)



**Note:** Do not mix and match sync modules with strobes from different manufacturers because each manufacturer uses different synchronization protocols.

Manufacturer	Part #	Sync. Module	Candela	Rated Current (mA)	Max # per NAC
Mircom	FH-400-WW, FH-400-RR, FS-400-WW, FS-400-RR, FS-400C-WW, FS-400C-RR, FHS-400-WW, FHS-400-RR, FHS-400C-WW, FHS-400C-RR	MIX-4050	15	69	25
			30	99	17
			75	189	9
			15/75	190	9

Manufacturer	Brand	Sync. Module	Horns/Strobes	Maximum # of Horns/Strobes
Cooper Wheelock	Cooper Wheelock	DSM-12-24	NS-24MCW-FW/-FR Horn/Strobes	13
Gentex	Secutron	AVS44-R	MRA-HS3-24 Horn/Strobe	8
SpectrAlert	System Sensor	MDL	P1224 MC Horn/Strobe	12
Amseco/Potter	Mircom	SDM-240	FHS-240-110 Horn/Strobe	9
Faraday	Siemens	DSC(-W)	ZR-MC-R/-W, ST-MC-R-AR, MTH-MC Strobes	15
			ZH-MC-R/-W Horn/Strobes	12
			ZH-R/-W Horns	22
Faraday	Faraday	DSC	6234 Series Horn/Strobes <b>Note:</b> Separate Circuit for Horn & Strobe	9

## Compatible Bells

Brand	Bells	Maximum # of Bells
Siemens	MBDC-6, -10 Bells	30
	B10-115-R Bell	14
	B6-24AC-R Bell	2



**Note:** Synchronization is on a NAC zone basis.

# Appendix C: Specifications

Table 12 FR-320 Series Specifications

FR-320 Series Fire Control Panel Chassis	
<b>General</b>	Digital Signal Processor (DSP) based design. Fully configurable using front panel LCD display with Password Access.
<b>Notification Appliance Circuits</b>	2 supervised class B Notification Appliance Circuits, configured as strobes or audibles. Terminals are labeled <b>SIG 1</b> and <b>SIG 2</b> .  Power limited / Regulated 24VDC FWR / 1.7A @ 49C per circuit
<b>Initiating Circuits</b>	6 supervised class B initiating circuits, configurable. Terminals are labeled <b>DET</b> . Compatibility ID <b>A</b> .  Power limited / 19VDC reg. / 3mA for detectors /110MVpp AC ripple / 45mA max (alarm short)
<b>Releasing Circuits</b>	Terminals are labeled <b>SIG 3</b> and <b>SIG 4</b>  Power limited / Special Application 21.1 VDC @ 1 A max per circuit, 1.7 A max combined  See Appendix A for compatible solenoids.
<b>Supervised Auxiliary Power (non resettable)</b>	Power limited / 21.1 VDC regulated / 300mA max, class B
<b>4-wire smoke supply (resettable)</b>	Power limited / 21.1 VDC regulated / 100mA max  Use Class B with EOL relay
<b>RS-485 Connection</b>	For Remote Annunciators. Terminals are labeled RS485. Line impedance is 120 Ω.
<b>Electrical ratings</b>	<p><b>AC line voltage</b> 120 VAC 60Hz 1.75 A / 240 VAC 50 Hz 0.93 A, 10A slow blow fuse on secondary of transformer</p> <p><b>Power Supply Rating</b> 6.5AAC maximum @ secondary of transformer</p> <p><b>Max power allowed</b> = 5A</p> <ul style="list-style-type: none"> <li>• 1.7A (aux power unfiltered if used)</li> <li>• 0.5A (aux power filtered if used)</li> <li>• 0.3A (resettable auxiliary power if used)</li> <li>• 1.7A (for releasing circuits)</li> </ul> <p><b>Note:</b> If no auxiliaries are used the maximum power is 5 A for the Notification Appliance Circuits and the releasing circuits.</p>

Table 12 FR-320 Series Specifications (Continued)

FR-320 Series Fire Control Panel Chassis	
<b>Auxiliary relays (resistive loads)</b>	Must be connected to a listed power limited source of supply. Terminals are labelled <b>ALARM, TROUBLE, SUPV</b> and <b>AUX</b> .
	<b>Common Alarm</b> Form C, 1 A max, 28 VDC
	<b>Common Supv</b> Form C, 1 A max, 28 VDC
	<b>Common Trouble</b> Form C, 1 A max, 28 VDC
	<b>Aux Relay</b> Form C, 1 A max, 28 VDC
<b>Unfiltered supply (full wave rectified)</b>	Power limited / Unregulated / Special Application 1.7A max, 21.3 VDC to 42.00 VDC Minimum Load 5mA
<b>Battery</b>	<b>Type</b> 24VDC Gel Cell/Sealed lead acid – 10AH to 26AH
	<b>Charging capability</b> 10AH to 26AH
	<b>Protection</b> 10A on board (F1) slow blow micro fuse
<b>Ground Fault Circuit</b>	Less than 3.3 kΩ will generate a ground fault. Testing impedance: 1 MΩ open, 0.1 Ω short
<b>Compliance</b>	<b>System Model</b> FR-320 Series Control Unit - Fire Alarm, for Releasing services
	<b>System Type</b> Local
	<b>Type of Service</b> A, M, WF, SS
	<b>Type of Signaling</b> Non-Coded
	<b>Applicable Standards</b> NFPA 12, 12A, 15, 16, 70, 72, UL-864, ULC-S524, ULC-S527

Table 13 FR-320 Series System Modules and Annunciators

FR-320 Series System Modules and Annunciators	
<b>RM-306 Relay adder module</b>	Must be connected to a listed power-limited source of supply <b>Contact rating</b> FormC/ 28VDC per contact / 1A resistive load max, zoned <b>Current consumption</b> standby 0mA, alarm 80mA
<b>ICAC-306 Input Class A Converter module</b>	Standby: 0mA / alarm: 0mA
<b>OCAC-302 Output Class A Converter module</b>	Standby: 0mA / alarm: 0mA

**Table 13 FR-320 Series System Modules and Annunciators (Continued)**

<b>FR-320 Series System Modules and Annunciators</b>	
<b>SRM-312W Smart Relay Module</b>	Must be connected to a listed power-limited source of supply <b>Contact rating</b> FormC/ 28VDC per contact / 1A resistive load max, zoned <b>Current consumption</b> standby 30mA / alarm 140mA
<b>RAM-208 8 Zone Remote Annunciator</b>	Standby 35mA / alarm 90mA
<b>RTI-1 Remote Trouble Indicator</b>	Standby 35mA / alarm 35mA

AS PER NFPA 72: System releasing circuits will not initiate an alarm signal due to movement of waste water, surges, or variable pressure.

# Appendix D: Power Supply and Battery Calculations

Use the form below to determine the required secondary power supply (batteries).

IMPORTANT NOTICE							
The main AC branch circuit connection for Fire Alarm Control Panel must provide a dedicated continuous power without provision of any disconnect devices. Use #12 AWG wire with 600-volt insulation and proper over-current circuit protection that complies with the local codes. Refer to Appendix C for specifications.							
POWER REQUIREMENTS (ALL CURRENTS ARE IN AMPERES)							
Model Number	Description	Qty		Standby	Total Standby	Alarm	Total Alarm
FR-320-R/ FR-320-W	Pre-Action/Deluge and Agent Release Control Panel FIXED ELR/ACTIVE ELR		X	0.123/0.092	=	0.316/ 0.292	=
ICAC-306	Det Class A Converter Adder Module		X	0.000	=	0.000	=
OCAC-302	Sig Class A Converter Adder Module--2 Circuits		X	0.000	=	0.000	=
RM-306	6 Relay Adder Module		X	0.000	=	0.080	=
SRM-312W/ SRM-312R	12 Relay Smart Relay Module		X	0.030	=	0.140	=
RAM-208	Remote Annunciators		X	0.035	=	0.090	=
RTI-1	Remote Trouble Indicator		X	0.035	=	0.035	=
Two-Wire Smoke Detectors			X	* 0.00011	=	* 0.135	=
Four-Wire Smoke Detectors			X		=		=
Signal Load (bells, horns, strobes, and etc.)			X				=
Auxiliary Power Supply for Annunciators, etc.					=		=
Total currents (Add above currents)				STANDBY	(A)	ALARM	(B)

\* Assume three Initiating Circuits are in alarm.

' Use **0.084** for five minutes, 0.168 for 10 minutes and 0.5 for 30 minutes of alarm as a multiplier figure.

\* Using the Mircom MPD-65P 2-wire photoelectric smoke detector. See LT-1007 Conventional Device Compatibility Guide for other compatible smoke detectors.

**Total Current Requirement: ALARM (B)** \_\_\_\_\_ Amps. (Value obtained from column **B**)

Battery Capacity Requirement:

**Battery (AH) =** ([STANDBY (A) \_\_\_\_\_ ] x [(24,60 or 90 Hours) \_\_\_\_\_ ] +

[(ALARM (B) \_\_\_\_\_ ] x [Alarm in Hr.] \_\_\_\_\_ ) = (C) \_\_\_\_\_ AH

**Total System Current in Alarm State:** Must be 5.5 amperes or less for FR-320 Series.

**Battery Selection:** Multiply (C) by 1.25 to derate battery.

# Warranty and Warning Information

## WARNING!

Please read this document **CAREFULLY**, as it contains important warnings, life-safety, and practical information about all products manufactured by the Mircom Group of Companies, including Mircom and Secutron branded products, which shall include without limitation all fire alarm, nurse call, building automation and access control and card access products (hereinafter individually or collectively, as applicable, referred to as “**Mircom System**”).

### NOTE TO ALL READERS:

1. **Nature of Warnings.** The within warnings are communicated to the reader out of an abundance of caution and create no legal obligation for Mircom Group of Companies, whatsoever. Without limiting the generality of the foregoing, this document shall NOT be construed as in any way altering the rights and obligations of the parties, governed by the legal documents that apply in any given circumstance.
2. **Application.** The warnings contained in this document apply to all Mircom System and shall be read in conjunction with:
  - a. the product manual for the specific Mircom System that applies in given circumstances;
  - b. legal documents that apply to the purchase and sale of a Mircom System, which may include the company’s standard terms and conditions and warranty statements;
  - c. other information about the Mircom System or the parties’ rights and obligations as may be application to a given circumstance.
3. **Security and Insurance.** Regardless of its capabilities, no Mircom System is a substitute for property or life insurance. Nor is the system a substitute for property owners, renters, or other occupants to act prudently to prevent or minimize the harmful effects of an emergency situation. Building automation systems produced by the Mircom Group of Companies are not to be used as a fire, alarm, or life-safety system.

### NOTE TO INSTALLERS:

All Mircom Systems have been carefully designed to be as effective as possible. However, there are circumstances where they may not provide protection. Some reasons for system failure include the following. As the only individual in contact with system users, please bring each item in this warning to the attention of the users of this Mircom System. Failure to properly inform system end-users of the circumstances in which the system might fail may result in over-reliance upon the system. As a result, it is imperative that you properly inform each customer for whom you install the system of the possible forms of failure:

4. **Inadequate Installation.** All Mircom Systems must be installed in accordance with all the applicable codes and standards in order to provide adequate protection. National standards require an inspection and approval to be conducted by the local authority having jurisdiction following the initial installation of the system and following any changes to the system. Such inspections ensure installation has been carried out properly.
5. **Inadequate Testing.** Most issues and/or problems that would prevent a Mircom System alarm from operating as intended, can be identified through regular testing and maintenance. The complete system should be tested by the local authority having jurisdiction immediately after a fire, storm, earthquake, accident, or any kind of construction activity inside or outside the premises. The testing should include all sensing devices, keypads, consoles, alarm indicating devices and any other operational devices that are part of the system.

## NOTE TO USERS:

All Mircom Systems have been carefully designed to be as effective as possible. However, there are circumstances where they may not provide protection. Some reasons for system failure include the following. The end user can minimize the occurrence of any of the following by proper training, testing and maintenance of the Mircom Systems:

6. **Inadequate Testing and Maintenance.** It is imperative that the systems be periodically tested and subjected to preventative maintenance. Best practices, local codes, applicable laws and industry regulations, and any local authority having jurisdiction to do so, determine the frequency and type of testing that is required at a minimum. Mircom System may not function properly, and the occurrence of other system failures identified below may not be minimized, if the periodic testing and maintenance of Mircom Systems is not completed with diligence and as required.
7. **Improper Operation.** It is important that all system users be trained in the correct operation of the alarm system and that they know how to respond when the system indicates an alarm. A Mircom System may not function as intended during an emergency situation where the user is unable to operate a panic or emergency switch by reason of permanent or temporary physical disability, inability to reach the device in time, unfamiliarity with the correct operation, or related circumstances.
8. **Insufficient Time.** There may be circumstances when a Mircom System will operate as intended, yet the occupants will not be protected from the emergency due to their inability to respond to the warnings in a timely manner. If the system is monitored, the response may not occur in time enough to protect the occupants or their belongings.
9. **Carelessness or Safety Hazards.** Moreover, smoke detectors may not provide timely warning of fires caused by carelessness or safety hazards such as smoking in bed, violent explosions, escaping gas, improper storage of flammable materials, overloaded electrical circuits or children playing with matches or arson.
10. **Power Failure.** Some Mircom System components require adequate electrical power supply to operate. Examples include: smoke detectors, beacons, HVAC, and lighting controllers. If a device operates only by AC power, any interruption, however brief, will render that device inoperative while it does not have power. Power interruptions of any length are often accompanied by voltage fluctuations which may damage Mircom Systems or other electronic equipment. After a power interruption has occurred, immediately conduct a complete system test to ensure that the system operates as intended.
11. **Battery Failure.** If the Mircom System or any device connected to the system operates from batteries it is possible for the batteries to fail. Even if the batteries have not failed, they must be fully charged, in good condition, and installed correctly. Some Mircom Systems use replaceable batteries, which have a limited life-span. The expected battery life is variable and in part dependent on the device environment, usage and type. Ambient conditions such as high humidity, high or low temperatures, or large temperature fluctuations may reduce the expected battery life. Moreover, some Mircom Systems do not have a battery monitor that would alert the user in the event that the battery is nearing its end of life. Regular testing and replacements are vital for ensuring that the batteries function as expected, whether or not a device has a low-battery monitor.
12. **Physical Obstructions.** Motion sensors that are part of a Mircom System must be kept clear of any obstacles which impede the sensors' ability to detect movement. Signals being communicated by a Mircom System may not reach the receiver if an item (such as metal, water, or concrete) is placed on or near the radio path. Deliberate jamming or other inadvertent radio signal interference can also negatively affect system operation.
13. **Wireless Devices Placement Proximity.** Moreover all wireless devices must be a minimum and maximum distance away from large metal objects, such as refrigerators. As the end user, you are required to consult the specific Mircom System manual and application guide for any

maximum distances required between devices and suggested placement of wireless devices for optimal functioning.

14. **Failure to Trigger Sensors.** Moreover, Mircom Systems may fail to operate as intended if, motion, heat, carbon monoxide (CO) and/or smoke sensors, are not triggered.
  - a. Sensors in a fire system may fail to be triggered when the fire is in a chimney, walls, roof, or on the other side of closed doors. Smoke and heat detectors may not detect smoke or heat from fires on another level of the residence or building. In this situation the control panel may not alert occupants of a fire.
  - b. Sensors in a nurse call system may fail to be triggered when movement is occurring outside of the motion sensors' range. For example, if movement is occurring on the other side of closed doors or on another level of the residence or building the motion detector may not be triggered. In this situation the central controller may not register an alarm signal.
15. **Interference with Audible Notification Appliances.** Audible notification appliances may be interfered with by other noise sources such as stereos, radios, televisions, air conditioners, appliances, or passing traffic. Audible notification appliances, however loud, may not be heard by a hearing-impaired person.
16. **Other Impairments.** Alarm notification appliances such as sirens, bells, horns, or strobes may not warn or waken a sleeping occupant if there is an intervening wall or door. It is less likely that the occupants will be alerted or awakened when notification appliances are located on a different level of the residence or premise.
17. **Software Malfunction.** Most Mircom Systems contain software. No warranties are provided as to the software components of any products or stand-alone software products within a Mircom System. For a full statement of the warranties and exclusions and limitations of liability please refer to the company's standard Terms and Conditions and Warranties.
18. **Telephone Line/Network Malfunction.** Telephone service can cause system failure where telephone lines/networks are relied upon by a Mircom System. Alarms and information coming from a Mircom System may not be transmitted if a phone line/network is out of service or busy for a certain period of time. Alarms and information may not be transmitted where telephone lines/networks have been compromised by criminal tampering, local construction, storms or earthquakes.
19. **Component Failure.** Although every effort has been made to make this Mircom System as reliable as possible, the system may fail to function as intended due to the failure of a component.
20. **Integrated Products.** Mircom System might not function as intended if it is connected to a non-Mircom product or to a Mircom product that is deemed non-compatible with a particular Mircom System. A list of compatible products can be requested and obtained.
21. A Mircom System's Auto Configuration feature is intended to assign the Alarm process type to all inputs and to provide an initial set up by detecting connected devices and generates a basic job configuration upon the initial installation of the Mircom System. Mircom makes no representations, warranties or guarantees regarding the accuracy or suitability of the basic job configuration generated upon installation, for any specific site requirements. The end user shall be solely and exclusively responsible to thoroughly review the basic job generated by the auto configuration feature upon initial installation and to implement necessary adjustments and modifications to customize the job configuration in accordance with the functional and/or technical requirements of the site. Mircom expressly disclaims any responsibility or liability for any failure, malfunction or defective operation of a Mircom System and any associated components, resulting from the end user's failure to customize or adjust the job configuration accordingly. By installing and utilizing the Mircom System, the user acknowledges and agrees that Mircom shall not be liable for any claims, losses, damages, or defects arising from the failure of the

user or installer and those for whom it is responsible at law, to customize the basic job configuration generated on the initial set-up in accordance with the requirements of the site.

## Warranty

**Purchase of all Mircom products is governed by:**

<https://www.mircom.com/product-warranty>

<https://www.mircom.com/purchase-terms-and-conditions>

<https://www.mircom.com/software-license-terms-and-conditions>



© Mircom 2026  
Printed in Canada  
Subject to change without prior notice

[www.mircom.com](http://www.mircom.com)

**CANADA - Main Office**  
25 Interchange Way  
Vaughan, ON L4K 5W3  
Tel: (905) 660-4655  
(888) 660-4655  
Fax: (905) 660-4113

**U.S.A**  
4575 Witmer Industrial Estates  
Niagara Falls, NY 14305  
Tel: (905) 660-4655  
(888) 660-4655  
Fax: (905) 660-4113